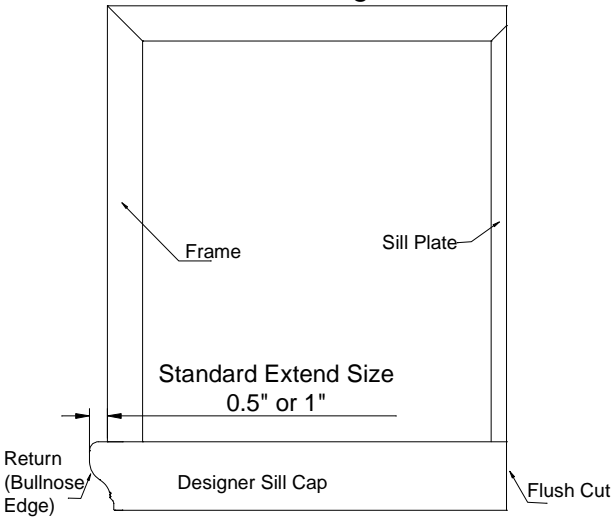
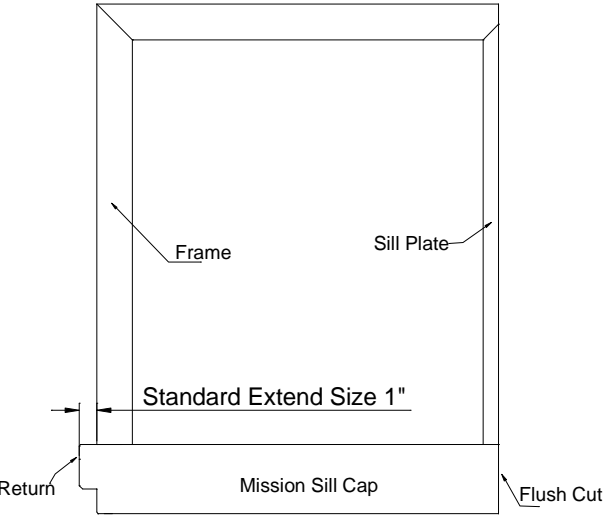

# NORMAN<sup>®</sup>

## S H U T T E R S

Brightwood Shutters

2024 Shutter Revision log

Effective Date	Topic	Section	Note
2024/02/01	Stile  Sill Cap	c,e,l	<p>c: Update stile information.</p> <p>e: Add content and drawings.</p>  <p>Please note that by <b>DEFAULT</b>: the <b>Designer Sill Cap</b> will be flush-cut and will not have a Return (bullnose edge) on the side(s) of the shutter that has a Sill Plate at the left and/or right side(s).</p> <p>When the customer indicates the existing sill width for the Designer Sill Cap, and the custom extended sill width is less than the standard: <b><u>1/2" extend on each side</u></b> (after calculation), then the standard <b><u>1/2" extend on each side</u></b> will be used.</p>  <p>Please note that by <b>DEFAULT</b>: the <b>Mission Sill Cap</b> will be flush-cut and will not have a Return on the side(s) of the shutter that has a Sill Plate at the left and/or right side(s).</p> <p>When the customer indicates the existing sill width for the Mission Sill Cap, and the custom extended sill width is less than the standard: <b><u>1" extend on each side</u></b> (after calculation), then the standard <b><u>1" extend on each side</u></b> will be used.</p>

2024 Shutter Revision log

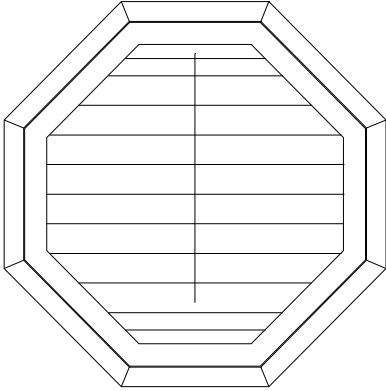
	Octagon		<p>l: Add content and drawing.</p> <div style="text-align: center;">  </div> <p>The left and right vertical stiles cannot be less than 8.125” for the panel to have hinges on the outer left and/or right stiles with L / R / LR / LTR configurations. For stiles less than 8.125” tall, the configuration must be RTL with panels hinged to the T post.</p>																		
2024/02/21	Sill Cap	e,k	<p>e: Change content from</p> <p>When the customer indicates the existing sill width for the Designer Sill Cap, and the custom extended sill width is less than the standard: <u>½” extend on each side</u> (after calculation), then the standard <u>½” extend on each side</u> will be used.</p> <p>When the customer indicates the existing sill width for the Mission Sill Cap, and the custom extended sill width is less than the standard: <u>1” extend on each side</u> (after calculation), then the standard <u>1” extend on each side</u> will be used.</p> <p>to</p> <table border="1" style="width: 100%; border-collapse: collapse;"> <thead> <tr> <th style="width: 15%;">Left side frame situation</th> <th style="width: 15%;">Right side frame situation</th> <th style="width: 60%;">judge extend size on each side for Designer Sill Cap &amp; Mission Sill Cap</th> <th style="width: 10%;">Notes</th> </tr> </thead> <tbody> <tr> <td style="text-align: center;">Frame</td> <td style="text-align: center;">Frame</td> <td>Calculation= (Existing sill width + 0.625” x 2 - MFF width) / 2</td> <td rowspan="4"> <p>When the customer indicates the existing sill width for the Designer Sill Cap, and the custom extended sill width is less than the standard: ½” extend on each side (after calculation), then the standard ½” extend on each side will be used.</p> <p>When the customer indicates the existing sill width for the Mission Sill Cap, and the custom extended sill width is less than the standard: 1” extend on each side (after calculation), then the standard 1” extend on each side will be used.</p> <p>Designer Sill Cap &amp; Mission Sill Cap will be flush cut on both ends</p> </td> </tr> <tr> <td style="text-align: center;">Frame</td> <td style="text-align: center;">Sill Plate</td> <td>Calculation= Existing sill width + 0.625” - MFF width</td> </tr> <tr> <td style="text-align: center;">Sill Plate</td> <td style="text-align: center;">Frame</td> <td>Calculation= Existing sill width + 0.625” - MFF width</td> </tr> <tr> <td style="text-align: center;">Sill Plate</td> <td style="text-align: center;">Sill Plate</td> <td>Close the Existing Sill Width field</td> </tr> </tbody> </table>		Left side frame situation	Right side frame situation	judge extend size on each side for Designer Sill Cap & Mission Sill Cap	Notes	Frame	Frame	Calculation= (Existing sill width + 0.625” x 2 - MFF width) / 2	<p>When the customer indicates the existing sill width for the Designer Sill Cap, and the custom extended sill width is less than the standard: ½” extend on each side (after calculation), then the standard ½” extend on each side will be used.</p> <p>When the customer indicates the existing sill width for the Mission Sill Cap, and the custom extended sill width is less than the standard: 1” extend on each side (after calculation), then the standard 1” extend on each side will be used.</p> <p>Designer Sill Cap &amp; Mission Sill Cap will be flush cut on both ends</p>	Frame	Sill Plate	Calculation= Existing sill width + 0.625” - MFF width	Sill Plate	Frame	Calculation= Existing sill width + 0.625” - MFF width	Sill Plate	Sill Plate	Close the Existing Sill Width field
Left side frame situation	Right side frame situation	judge extend size on each side for Designer Sill Cap & Mission Sill Cap	Notes																		
Frame	Frame	Calculation= (Existing sill width + 0.625” x 2 - MFF width) / 2	<p>When the customer indicates the existing sill width for the Designer Sill Cap, and the custom extended sill width is less than the standard: ½” extend on each side (after calculation), then the standard ½” extend on each side will be used.</p> <p>When the customer indicates the existing sill width for the Mission Sill Cap, and the custom extended sill width is less than the standard: 1” extend on each side (after calculation), then the standard 1” extend on each side will be used.</p> <p>Designer Sill Cap &amp; Mission Sill Cap will be flush cut on both ends</p>																		
Frame	Sill Plate	Calculation= Existing sill width + 0.625” - MFF width																			
Sill Plate	Frame	Calculation= Existing sill width + 0.625” - MFF width																			
Sill Plate	Sill Plate	Close the Existing Sill Width field																			
	Café Shutter		<p>k: Update drawing.</p>																		

2024 Shutter Revision log

2024/03/08	Features and Benefits	a	Add content: A wide selection of frames provides both the appearance and function to match your style and preference. Several of the frame options include a removable insert to keep installation screws out of sight for a clean look.
2024/03/16	InvisibleTilt	g,j2,k	Change InvisibleTilt™ / Invisible Tilt to InvisibleTilt®.
2024/05/08	Specialty Shutters	l	Update specialty shape information
2024/05/16	Custom colors	k	Custom colors update information.
	Horizontal T post  Frame include in Rail	e,l	e: Add content "For Double Hung shutter with a horizontal T post, the face width of the horizontal T post defaults to 1 3/4".  l: Add content "For this reason, the panel will not have any magnets or hinges, since it is a fixed panel."
2024/07/15 (MO date)	L Bracket 44mm	i	Add L Bracket 44mm and color coordination chart
2024/07	Specialty Shutters	l	Update and add content: The left and right vertical stiles cannot be less than 8.125" (for 2.375" series hinges) for the panel to have hinges on the outer left and/or right stiles with L / R / LR / LTR configurations. For stiles less than 8.125" (for 2.375" series hinges) tall, the configuration must be RTL with panels hinged to the T post.  For all specialty shape shutters, if the hinges are required, the smallest vertical stile straight height (net panel leg height) must be greater than 8 1/8" (for 2.375" series hinges) / 9 3/4" (for Direct Mount 3" hinge) to allow for hinge installation.  The limitations of these custom-made specialty shutters shown below are an approximate range. Actual limitations and availability vary depending on the width to height relationship, frame type, stile size, etc. This chart is used for general reference only.
2024/07/18	For bay window at 170 degree or above	e	Add content : Bay post will be used when the degrees of all bay posts in a Bay Window Shutter with both <170 degree and >= 170 degree at the same time.
2024/08/15	Bottom Pivot Brackets	j1	Update information of Bottom Pivot Brackets.



<u>Table of Contents</u>	<u>Page</u>
a. Features & Benefits	BW a-1
b. Colors & Louver Sizes/Louver Clearance	BW b-1
c. Stiles	BW c-1
d. Panel Configurations	BW d-1
e. Frame Styles	BW e-1
f. General Product Specifications	BW f-1
g. Tilt Rods	BW g-1
h. Divider Rails	BW h-1
i. Hardware	BW i-1
j. Track Shutters	BW j-1
k. Special Options	BW k-1
l. Specialty Shapes	BW l-1
m. Pricing	BW m-1

## Features and Benefits

- Enhance view with extremely wide panels. Up to 42” in width for each single panel to create the clean, streamlined look.
- Reinforced engineered stile-- Multiple layers of wood bonded together to reinforce durability to the core of the stile, which results in a robust support system for the shutter panel.
- Employs mortise and tenon joinery that resists shear and racking forces endured by shutters to ensure prolonged quality and durability.
- Quick and easy on-site assembly and installation with the pre-installed magnets and hinges, pre-mitered frames and slotted keyholes.
- Special panel and frame design that is custom cut to accommodate every unique windows.
- Personalize shutters with special options. Choose from fixed louvers, center or offset tilt rod, double hung panels, café shutters, track systems, French door cutout, specialty shapes and many more.
- A guarantee of Norman Shutters exemplary quality with a lifetime limited warranty on materials and workmanship.
- A wide selection of frames provides both the appearance and function to match your style and preference. Several of the frame options include a removable insert to keep installation screws out of sight for a clean look.

## Colors & Louver Sizes/Louver Clearance

No.	Color ID	Color Name
1	001	Pure White
2	002	Extra White
3	003	Silk White
4	004	Bright White
5	006	Pearl
6	007	Ivory Lace
7	009	Creamy
8	012	Crisp Linen
9	013	Bisque
10	017	Gray Black
11	019	String
12	032	Sea Mist
13	046	Ice
14	053	Clay
15	063	Decorator's White
16	066	Winchester White 2010
17	076	Aura White
18	080	Taupe Gray
19	836	Classic Black
20	090	TS White
21	600	True White
22	601	Chiffon
23	603	Natural Linen
24	609	Chateau Brown

- Please note that darker colors absorb more heat than lighter colors. As a result, shutters in darker colors that face direct sunlight for an extended period of time may absorb more heat, which may potentially affect the long-term performance of the shutter.

Louvers	
Elliptical	1 7/8"
	2 1/2"
	3"
	3 1/2"
	4 1/2"

\*Some surcharges apply

Louver Depth Clearance

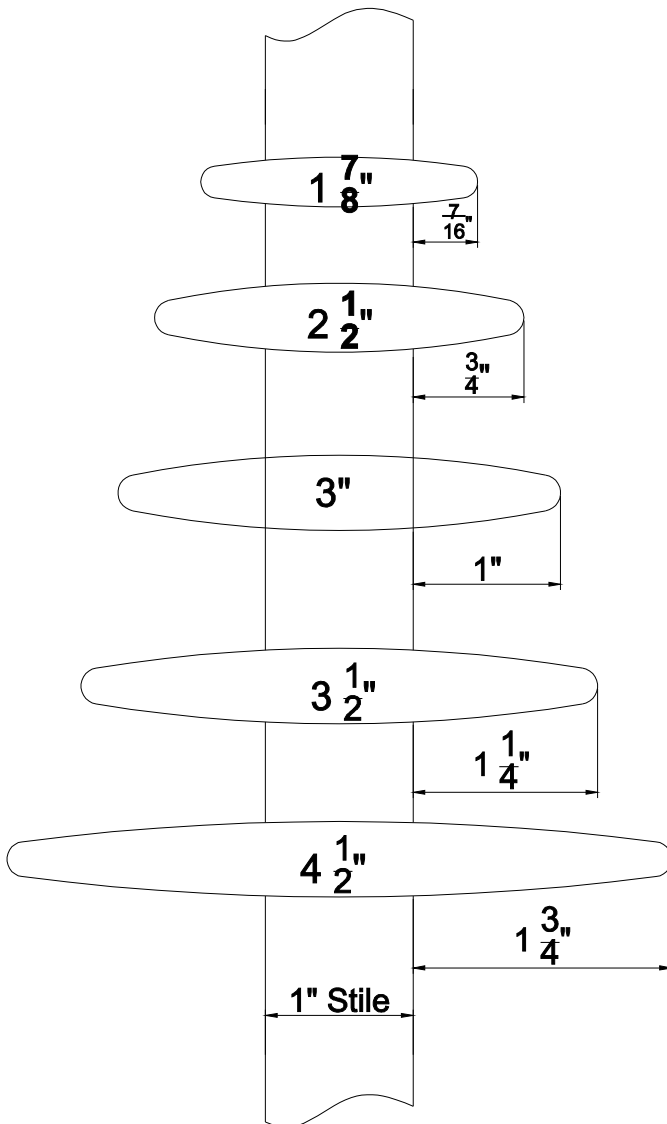

## Louver Depth Clearance for Specific Frames

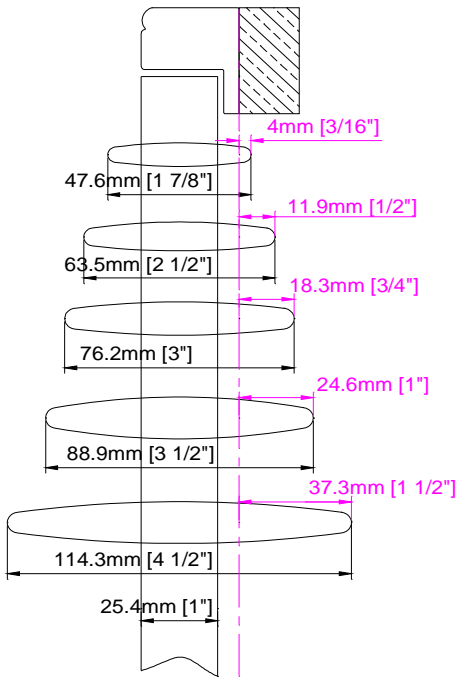

L Frame with 1/4" light block

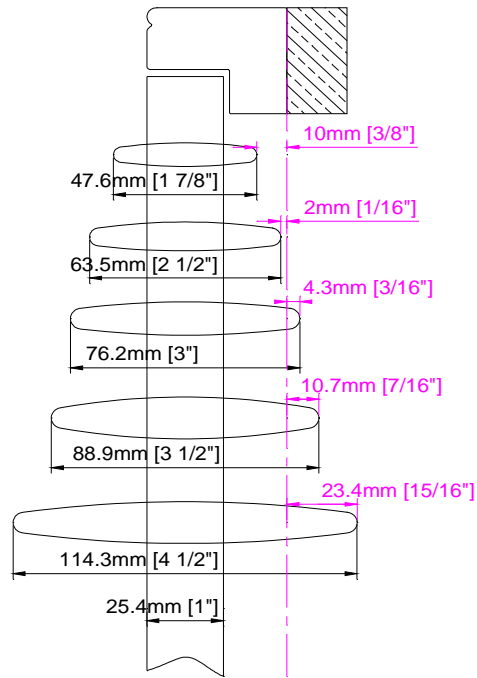

L Frame

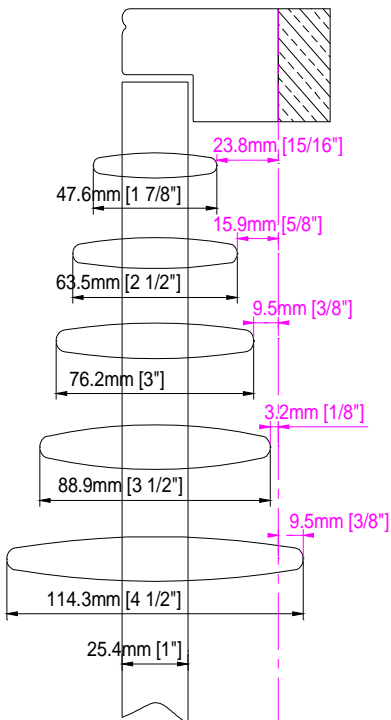

L Frame with 1/2" Buildout

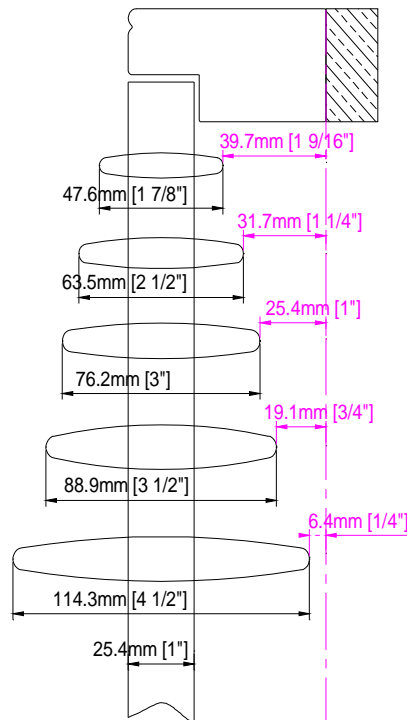

L Frame with 1" Buildout

\*Some surcharges apply

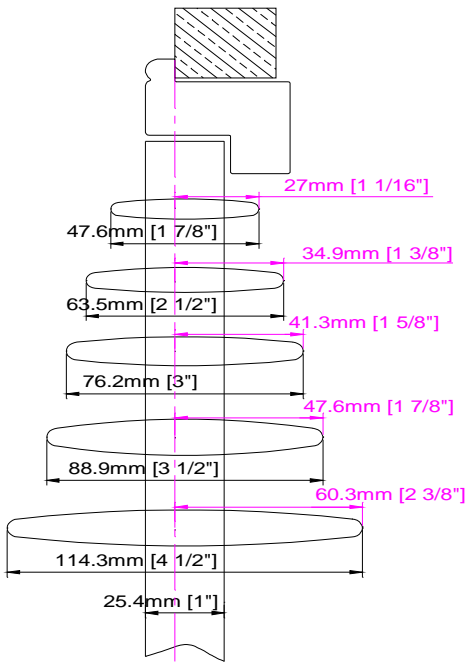

1 1/4" Beaded Z Frame

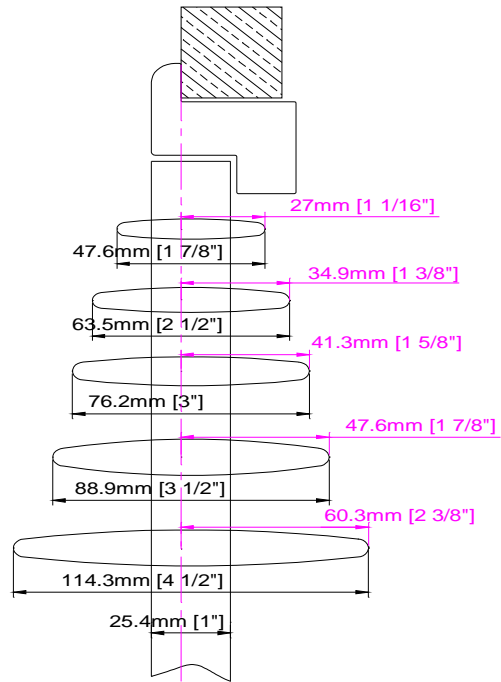

1 1/2" Bullnose Z Frame

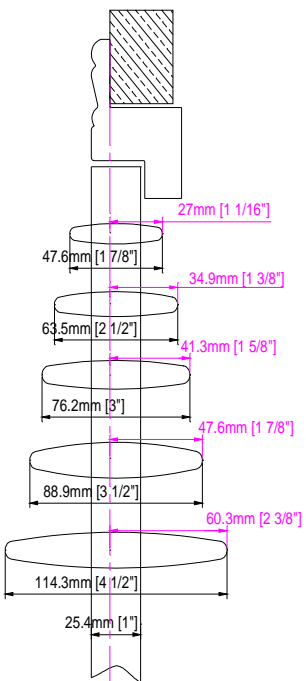

2" Bel Air Z Frame

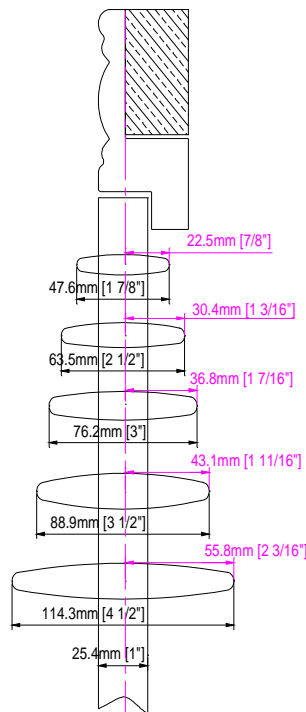

3" Crown Z Frame

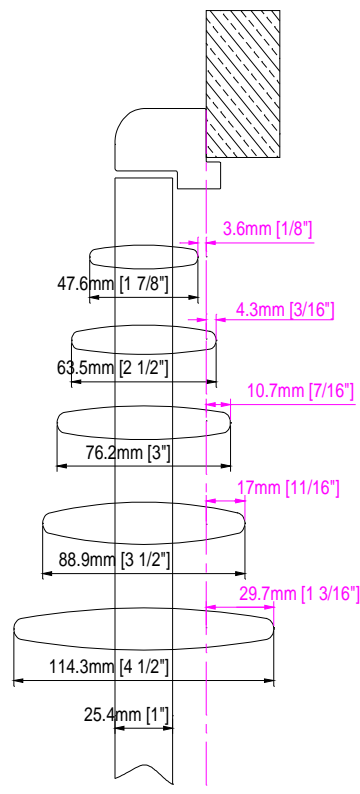

Tilt Out Z Frame

\*Some surcharges apply

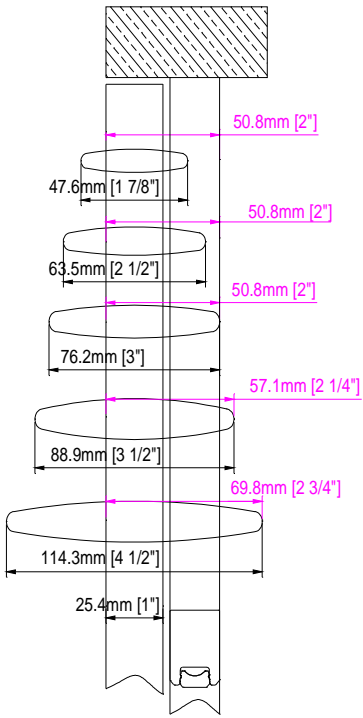

Hang Strip ( Behind the panel)

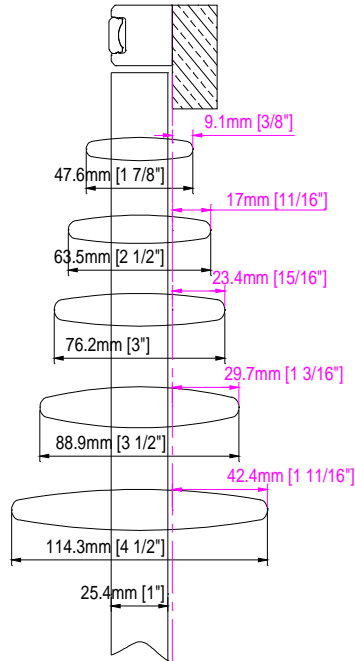

Hang Strip ( Beside the panel)

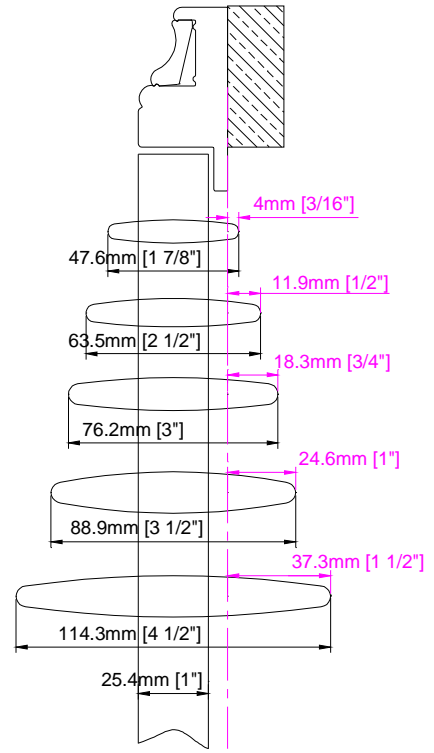

Deco Frame

## Stiles

### Default: Beaded stile

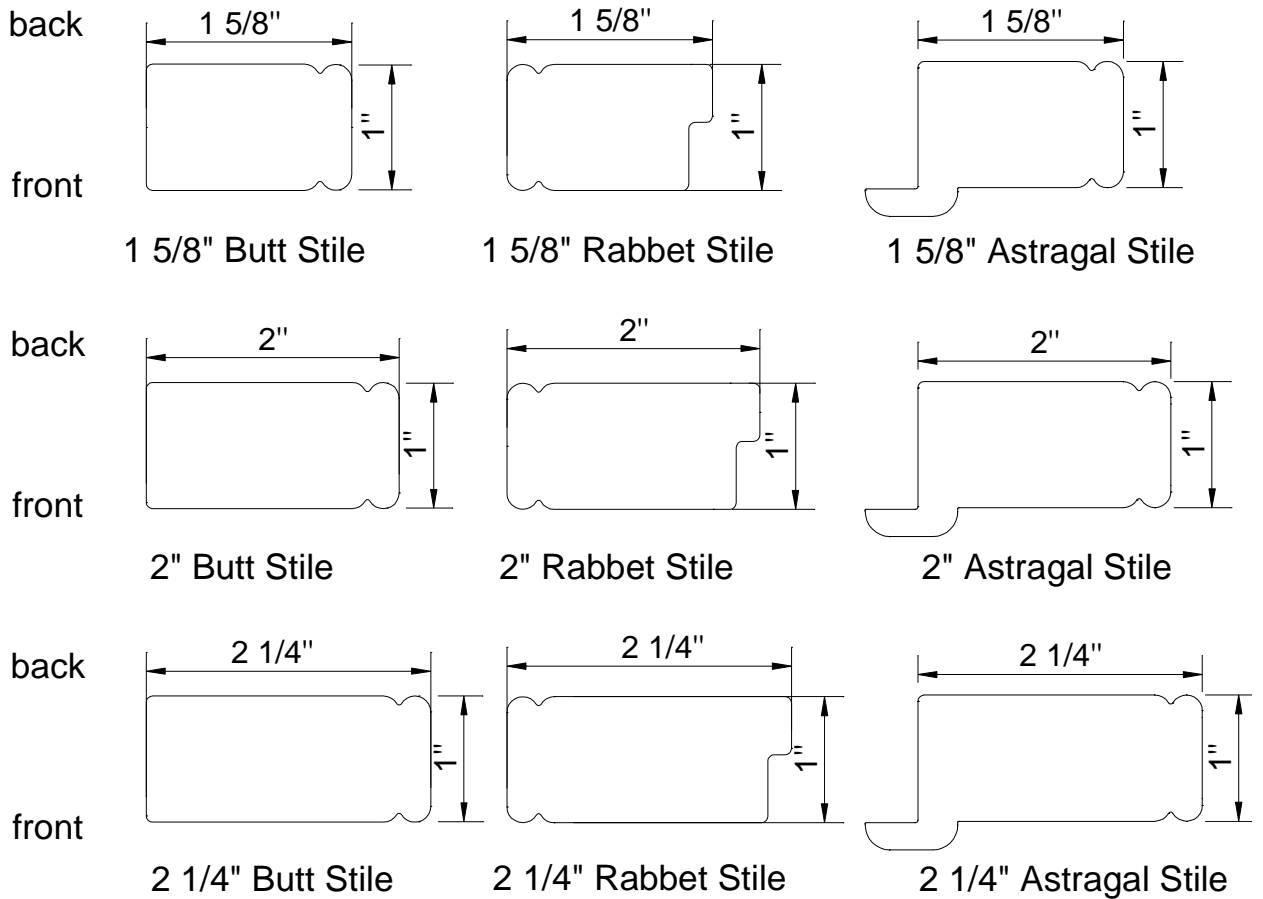

### Optional: Chamfer stile

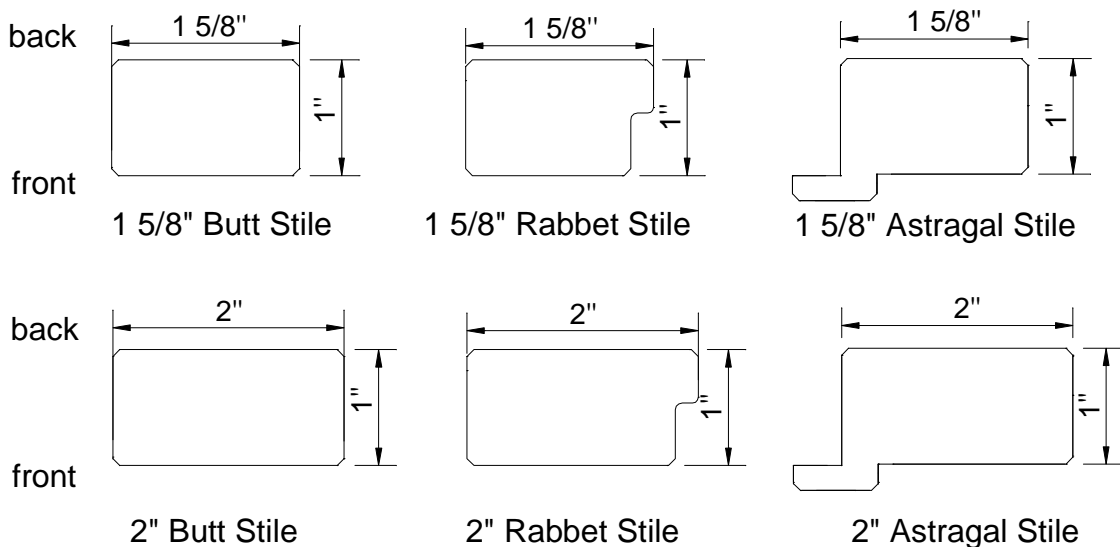



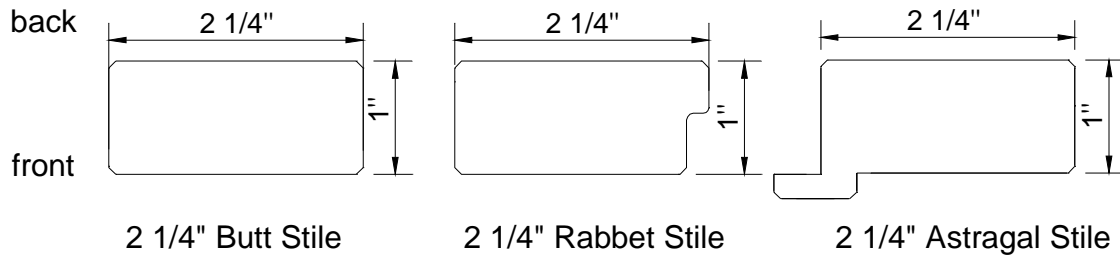

## Stiles (continued)

### Stile between panel closure

#### Single panel

##### I) Panel width < 9"

Rabbet stile (Deco frame, L frame, Z frame and Hang strip beside panel)

- 1 5/8"
- 2" (default)
- 2 1/4"



Butt stile only (Hang strip behind panel **and Direct Mount**)

- 1 5/8"
- 2" (default)
- 2 1/4"



##### II) Panel width ≥ 9"

Butt stile only

- 1 5/8" ( Optional for panel width ≤ 12" )
- 2" (default)
- 2 1/4"

#### 2 panels or more

Rabbet stile & Astragal stile

- 1 5/8" ( Optional for panel width ≤ 12" )
- 2" (default)
- 2 1/4"

# Panel Configurations

## Single Panel

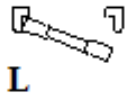

L

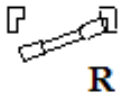

R

OR

## Two Panels



LR

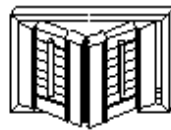

LL



RR

## Three Panels



LLR

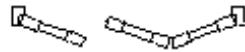

LRR

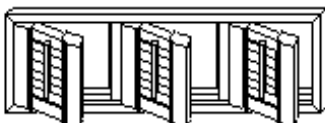

LTLTL

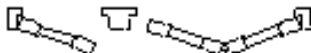
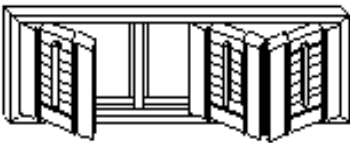

LTRR

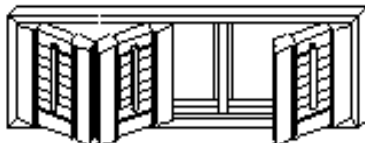

LLTR

**Four Panels**

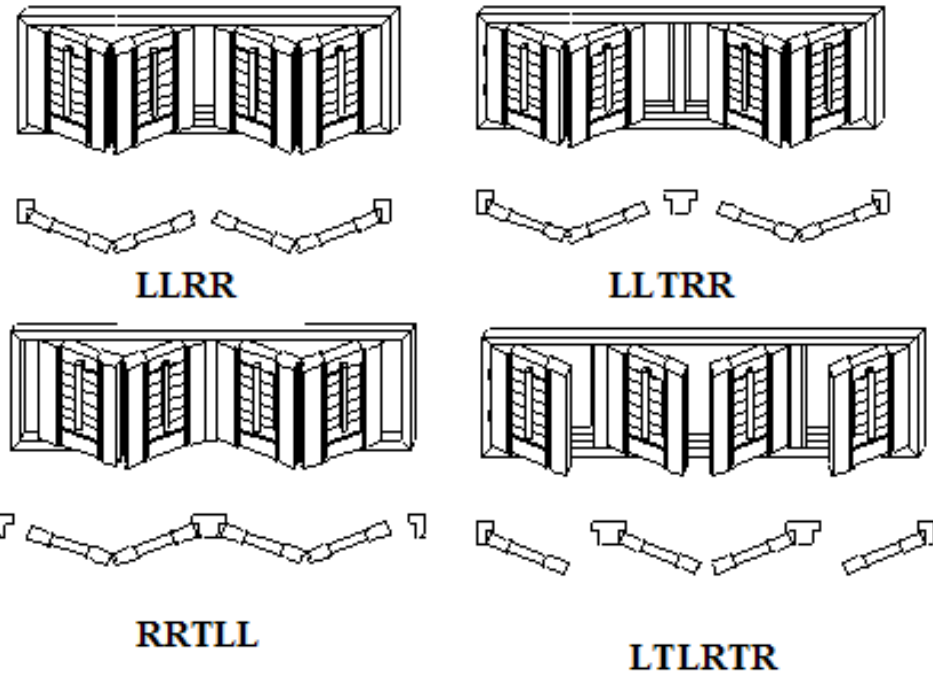

**Six Panels**

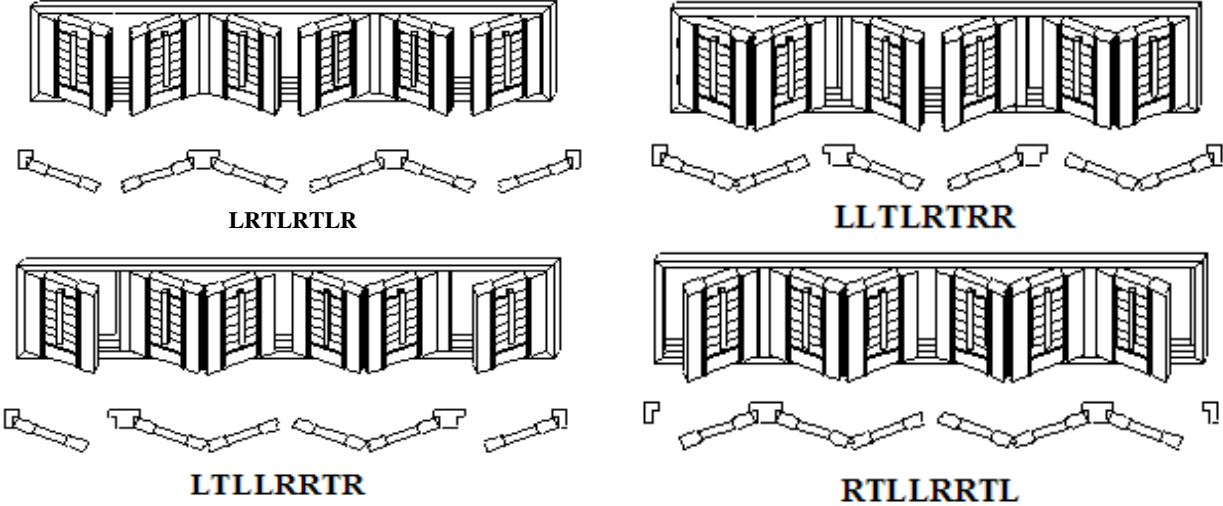

Panel Configurations – Astragal Stile

- 2 Panels – LR

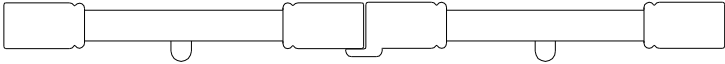

- 3 Panels - LRR

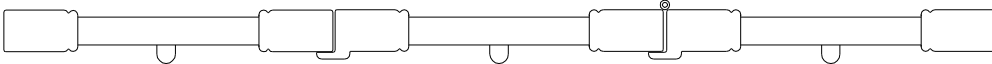

- 3 Panels – LLR

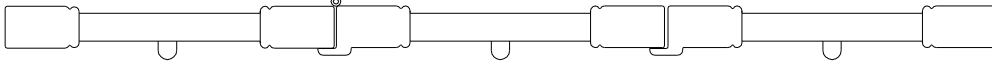

- 4 Panels - LLRR

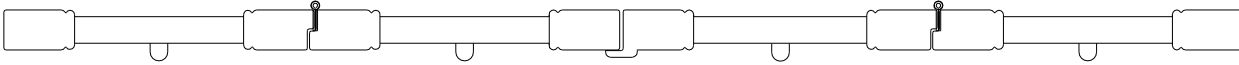

## Frame Style

Frame material: Woodlore Plus

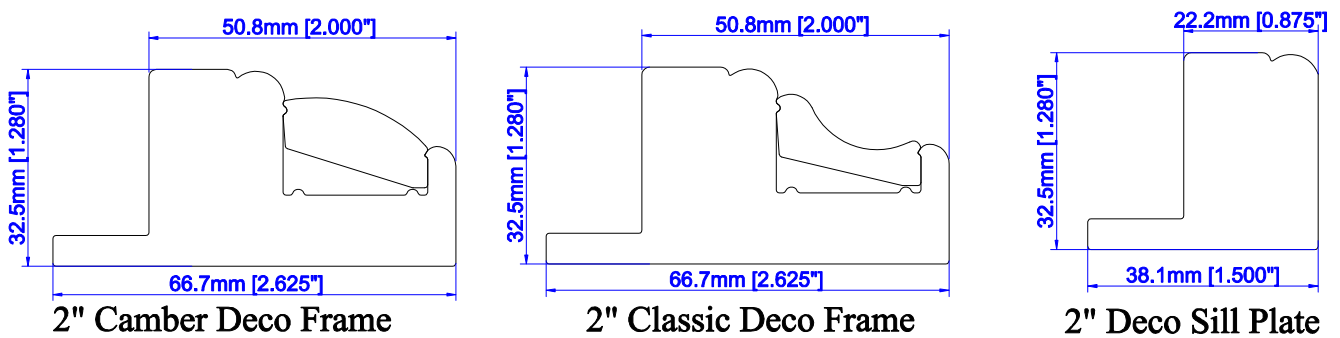
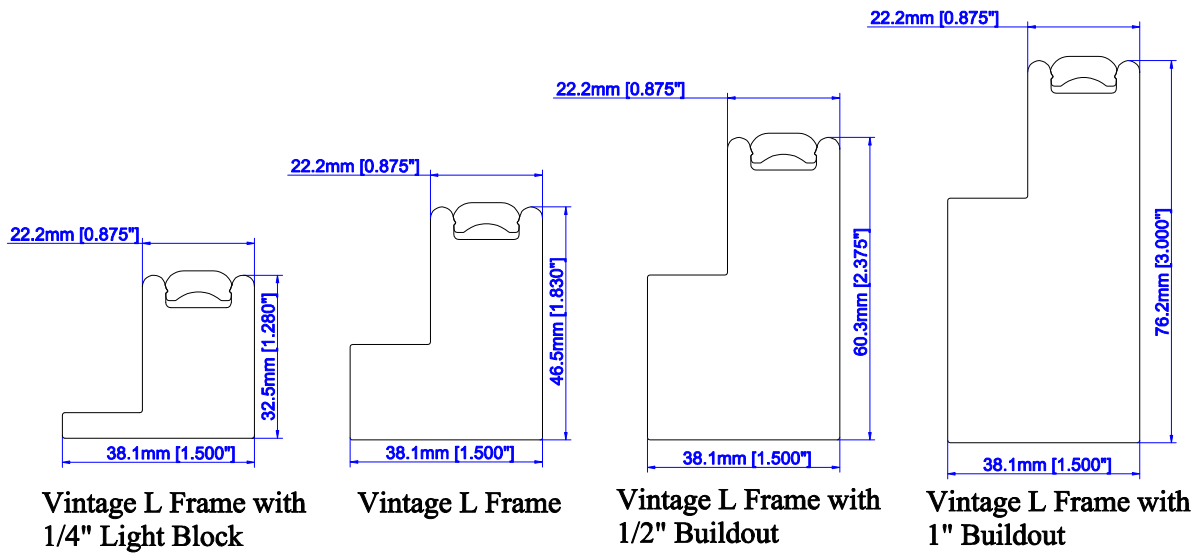
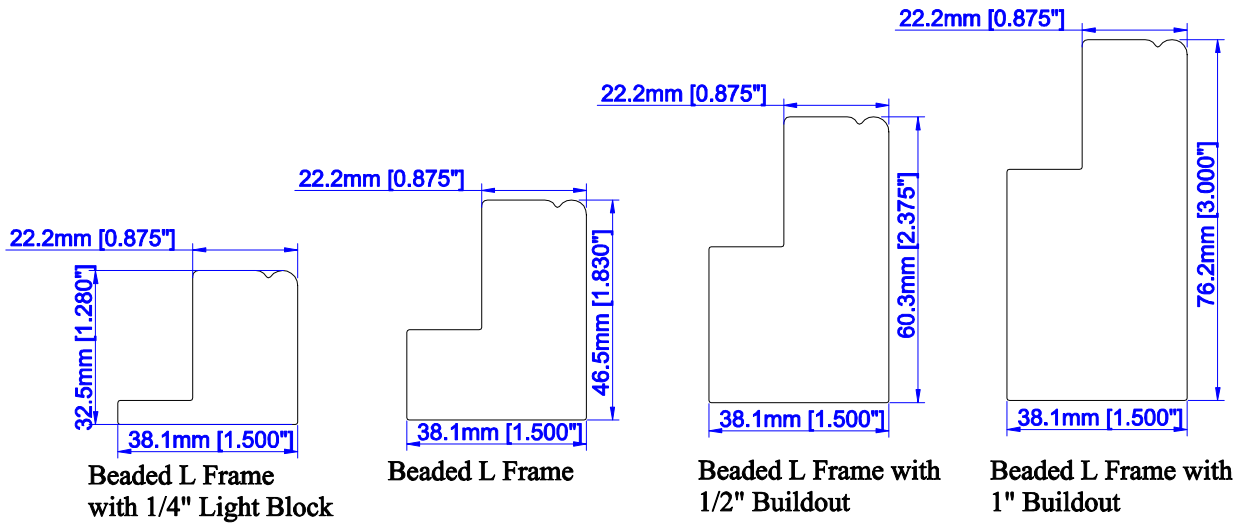

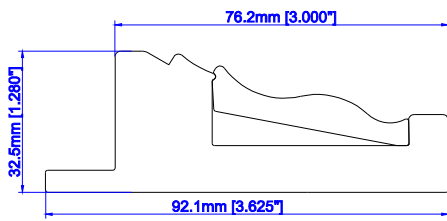

3" Ridge Deco Frame

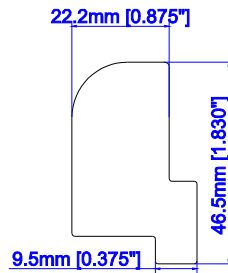

Tilt Out Z Frame

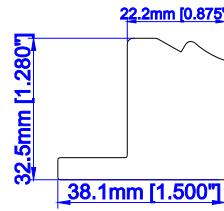

Ridge Deco Sill Plate

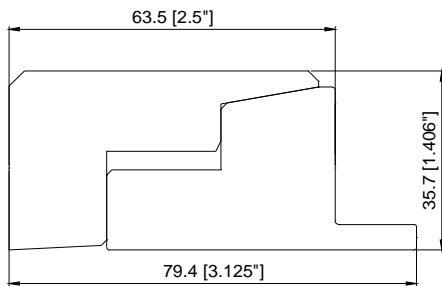

2.5" Mission Deco Frame

There are 2 options for the Deco frame installation when Window Size is given (Take Camber Deco frame as an example)

1. Default: light block part install into the window opening;

The window size is the exact size of the window opening;

The MFF size is the measurement of the entire shutter, including the frames;

The MFF size = Window Size + Face Width

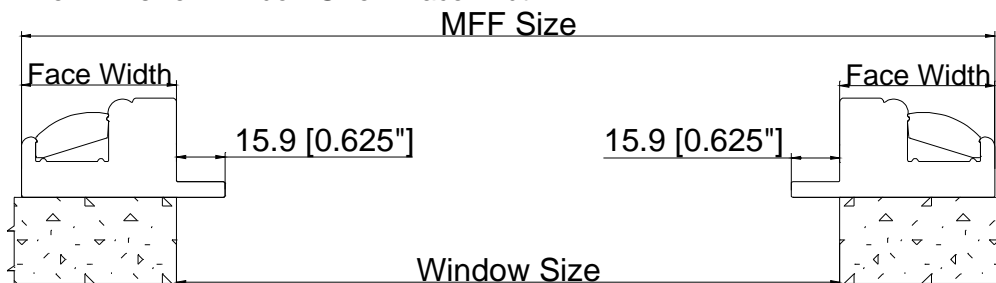

2. Optional: light block part flush with window opening.

The window size is the exact size of the window opening;

The MFF size is the measurement of the entire shutter, including the frames;

The MFF size = Window Size + Frame Back Width



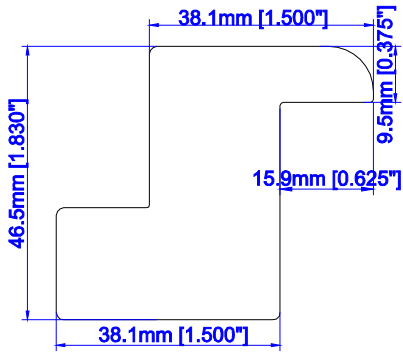

1 1/2" Bullnose Z Frame

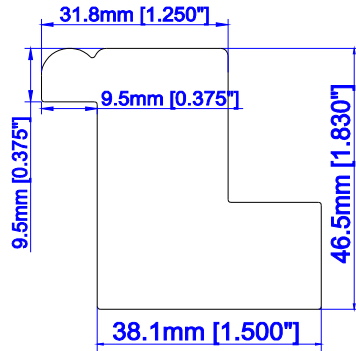

1 1/4" Beaded Z Frame

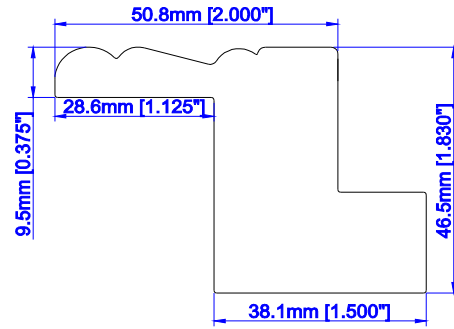

2" Bel Air Z Frame

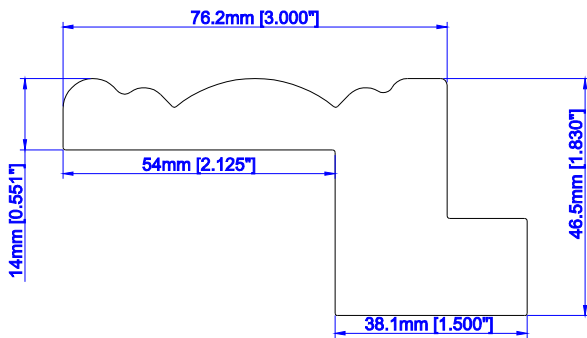

3" Crown Z Frame

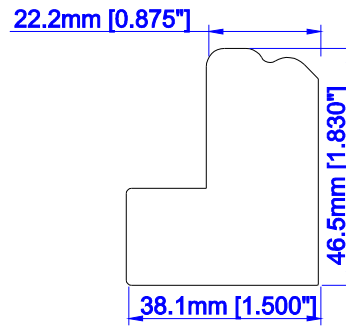

3" Crown Z Sill Plate

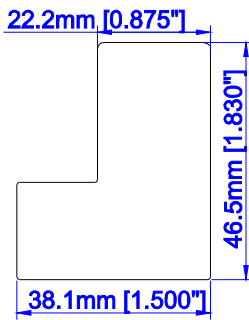

Bullnose Z  
1 1/4" Beaded Z  
Sill Plate

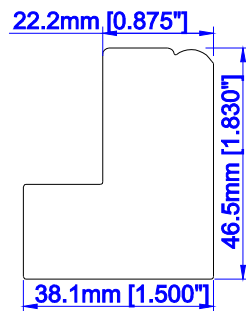

2" Bel Air Z Sill Plate

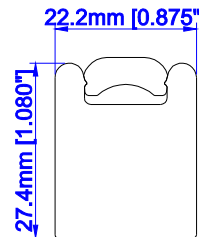

7/8" Vintage Hang Strip

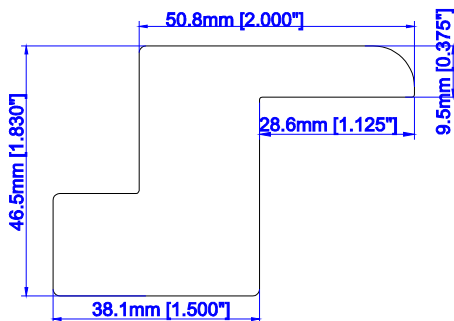

2" Bullnose Z Frame

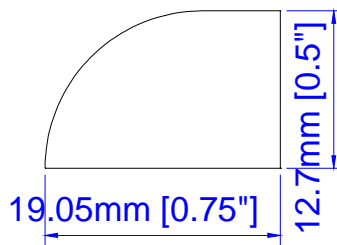

Quarter Round

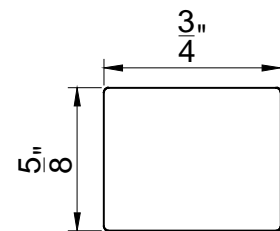

Light Block

Note: Quarter Round will be made in Wood.

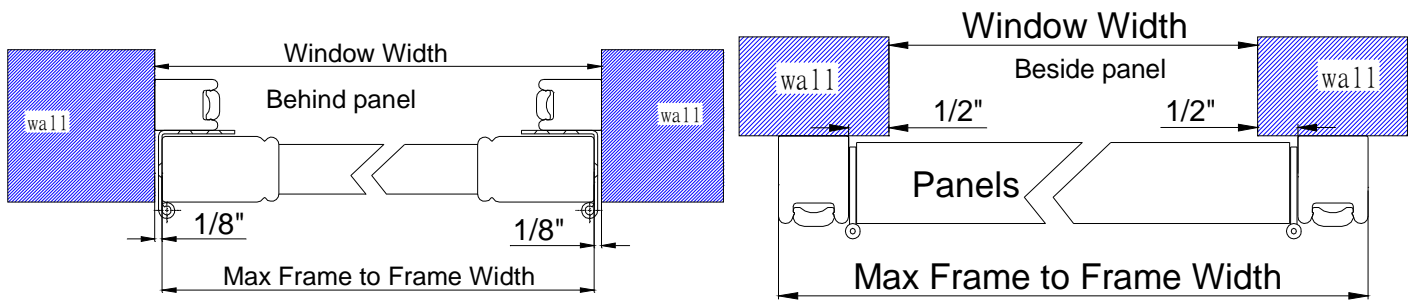

Note: Outside mounted hang strips, behind the panel, is not available for all 4 sides ("all around") or 3 sides inverted.

**Standard Sill Plate:**

The "Standard Sill Plate" is a sill plate that is made from the same frame type that is being used to mount the shutter. Standard Sill Plate is only available for Deco frames and Z frames (except Tilt Out Z frame). The Deco frame or Z frame is cut-down to convert it into a sill plate, and this enables the Standard Sill Plate to be mitered and connected to the side frames for a more seamless look.

The Standard Sill Plate can be used on any side of the shutter for a non-specialty shape: top, bottom, left or right.

The standard sill plate can be used on a specialty shape shutter on any side that is not curved. Standard sill plate is not available for the following specialty shapes: Circle, Oval, French door, Hexagon and Octagon.

**Note:** The Standard Sill Plate is the only type of sill plate that can be used in combination with a bottom Sill Cap.

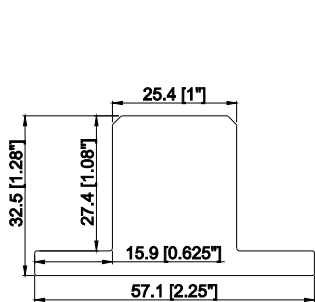

1" Chamfer T Post with 1/4" Light Block (Deco)

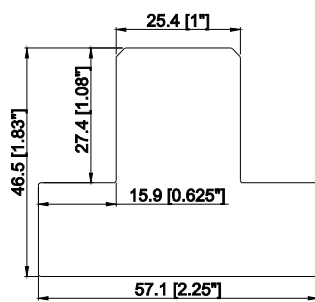

1" Chamfer T Post with 3/4" Light Block (L/Z/HS)

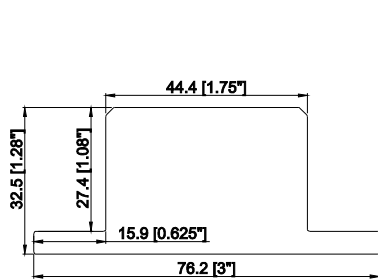

1.75" Chamfer T Post with 1/4" Light Block (Deco)

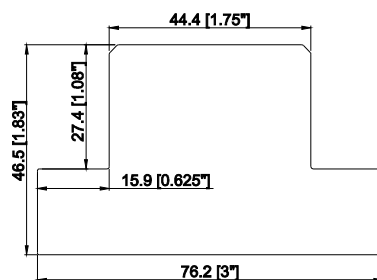

1.75" Chamfer T Post with 3/4" Light Block (L/Z/HS)



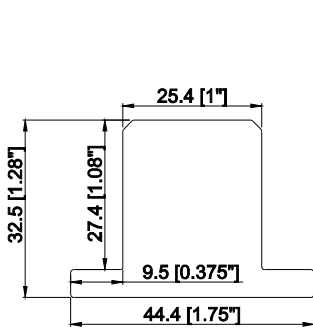

1" Chamfer T Post with 1/4" Thick x 3/8" Wide Light Block (Deco)

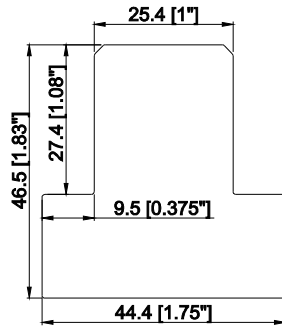

1" Chamfer T Post with 3/4" Thick x 3/8" Wide Light Block (L/Z/HS)

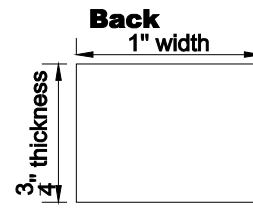

1" \* 3/4" Post (No light block)

Note: 1" Chamfer T Post with 3/4" Light Block, 1 3/4" Chamfer T Post with 3/4" Light Block, 1" Chamfer T Post with 3/4" Thick x 3/8" Wide Light Block and Custom Chamfer T Post with 3/4" Thick Light Block are not available for all Deco frames and L frames with 1/4" Light Block.

- Custom width\* up to 7 1/2" for T Posts (Made of Wood)
  - Size limits (7 1/2")
  - Available for composite but it will be made from wood
  - That a surcharge applies and customers should refer to their shutter pricing
  - Any limitations

Note: The 1"x3/4" Post (No Light Block) is only available for Direct Mount. And no hardware will be supplied to install it on the existing window opening.

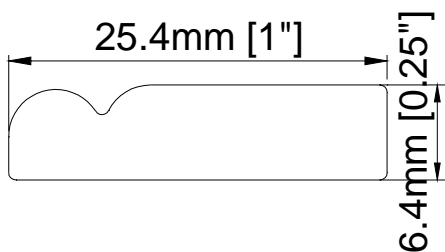

Scribe Trim 1

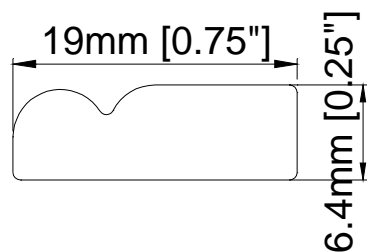

Scribe Trim 2

Note: Scribe Trim 1 & Scribe Trim 2 will be made from Woodlore Plus material.

### Standard Corner & Bay Posts

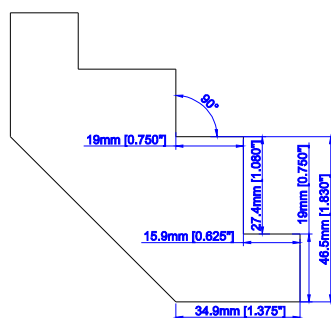

Corner Post with 3/4" Light Block (L/Z/HS)

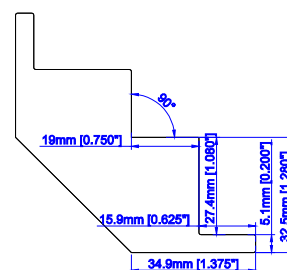

Corner Post with 1/4" Light Block (Deco)

\*Some surcharges apply

\*Notch out corner post required if ordering Z Frame with solid drywall corner.

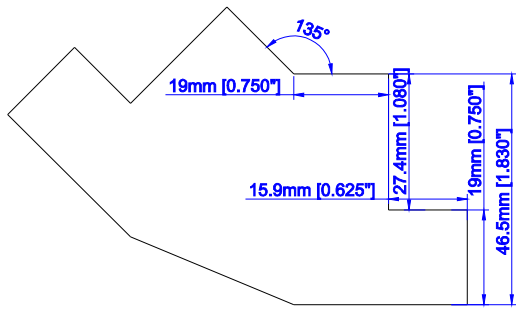

Bay Post with 3/4"  
Light Block (L/Z/HS)

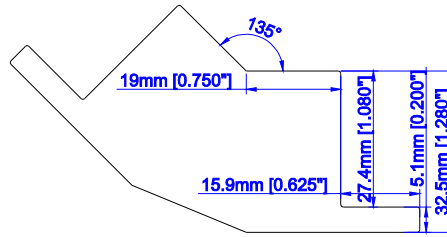

Bay Post with 1/4"  
Light Block (Deco)

Also available

- Custom angle bay posts\*

For bay window at 170 degree or above

- 1" T Post with 3/8" light block will be used as Bay post;
- For Hang Strip (Behind Panel), bay post will be used.
- Bay post will be used when the degrees of all bay posts in a Bay Window Shutter with both <170 degree and  $\geq 170$  degree at the same time.

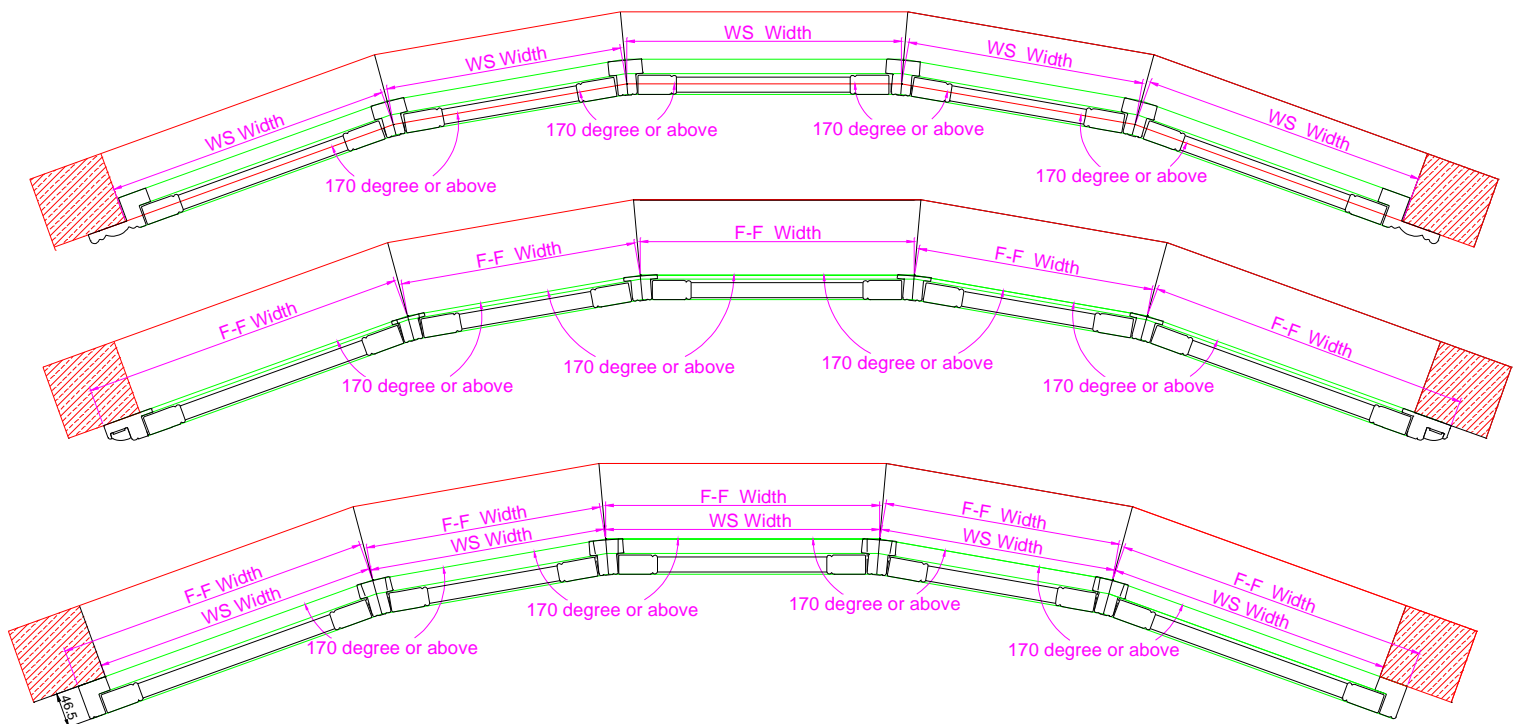

## Slim Fit Corner & Bay Posts

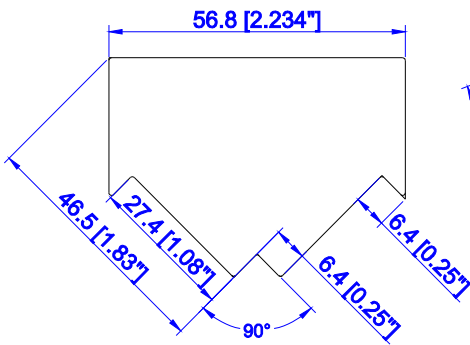

Slim Fit Corner Post for  
90 Degree (L/Z/HS)

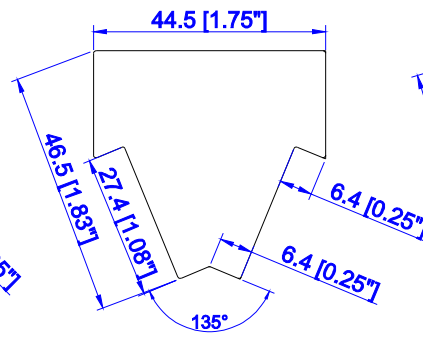

Slim Fit Bay Post for  
135 Degree (L/Z/HS)

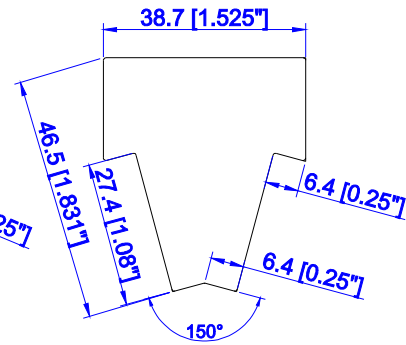

Slim Fit Bay Post for  
150 Degree (L/Z/HS)

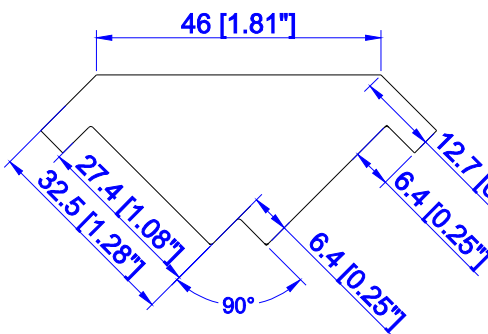

Slim Fit Corner Post for 90 Degree (D)

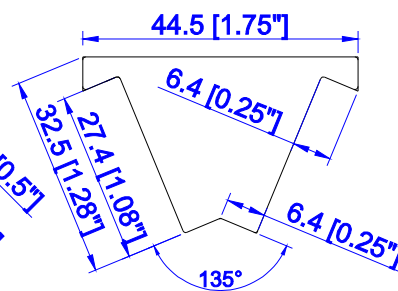

Slim Fit Bay Post for 135 Degree (D)

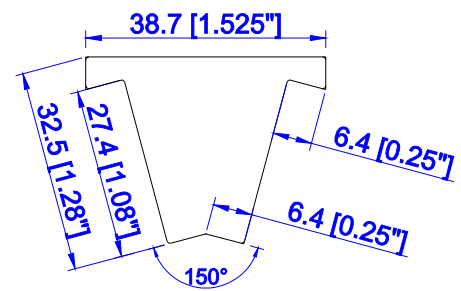

Slim Fit Bay Post for 150 Degree (D)

Note: Due to size and weight limitations, Slim Fit Posts may only be hinged on one side and with a single panel (no bi-folded panels). Please consider this when determining panel configuration.

- Slim Fit Posts are available in 90, 135 and 150 Degrees only.
- All Bay posts, Corner posts and Slim Fit Posts are made of Wood.

### In order to better match corner windows / bay windows:

- **For non sample orders, please note that corner windows must have the same:**
  - Post Type (Standard or Slim Fit)
  - Color
  - Hinge Options
  - Louver Size
  - Frame Type
  - Mount Type
  - Extension
  - Sill Options
  - T-Post Options
  - Height
  - Stile Type and Profile
  - Tilt Type
  - Divider Rail Options
  - Double-Hung Options

\*Some surcharges apply

- Split Tilt Options
- PerfectTilt Options

● **For non sample orders, please note that bay windows must have the same:**

- Post Type (Standard or Slim Fit)
- Color
- Hinge Options
- Louver Size
- Frame Type
- Mount Type
- Extension
- Sill Options
- T-Post Options
- Height
- Stile Type and Profile
- Tilt Type
- Divider Rail Options
- Double-Hung Options
- Split Tilt Options
- PerfectTilt Options

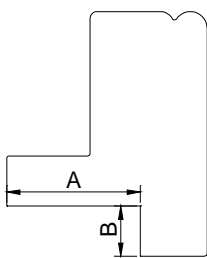

Notch Out  
Beaded L Frame (A) \*

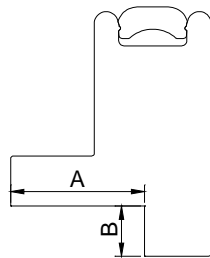

Notch Out  
Vintage L Frame (A) \*

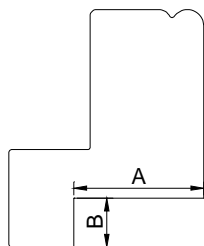

Notch Out  
Beaded L Frame (B) \*

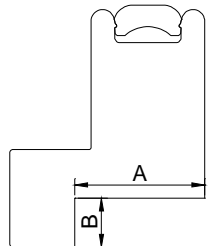

Notch Out  
Vintage L Frame (B)

Limitation for the Notch Out Size:

A ≤ 1"; B ≤ 1/2" for Beaded/Vintage L frame;  
A ≤ 1"; B ≤ 1" for Beaded/Vintage L frame  
with 1/2" Buildout;  
A ≤ 1"; B ≤ 1 5/8" for Beaded/Vintage L frame  
with 1" Buildout;

Note: Notch Out L frames cannot be ordered  
with sill options, including 2" Sill Plate, Sill  
Frames, or Sill Caps (due to installation issues  
that would result).

Note: Notch Out L frame is not available for L frames w/ 1/4" light block.

Sill Frames- For use where there is no existing sill

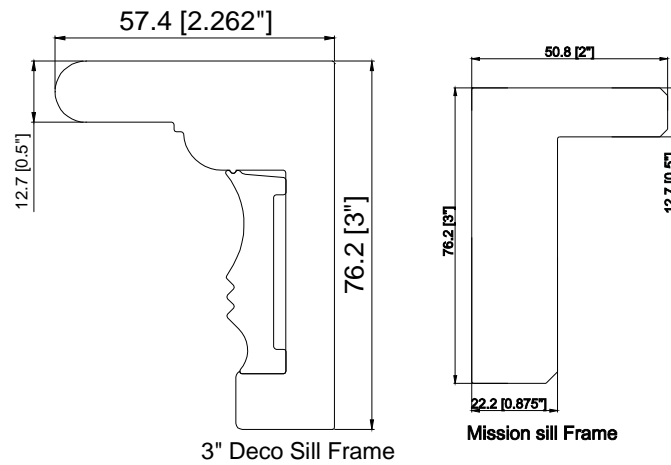

3" Deco Sill Frame

Mission sill Frame

Sill Caps-Used to cover existing sills

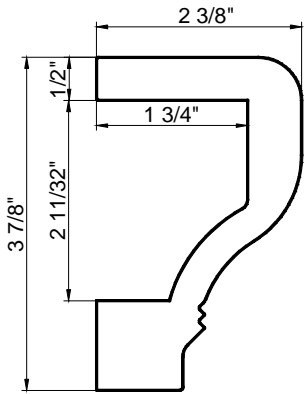

Designer Sill Cap (L)

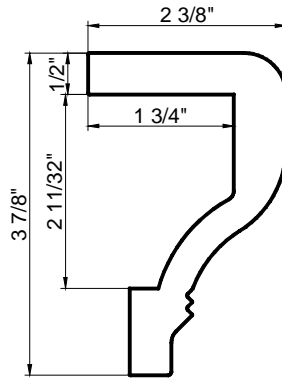

Designer Sill Cap (D/HS)

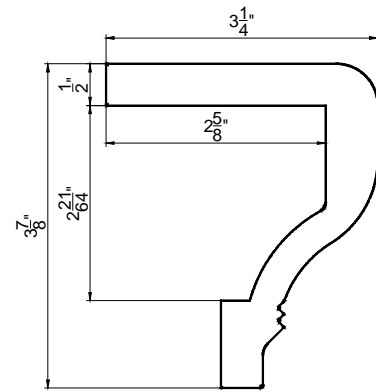

Designer Sill Cap (Z)

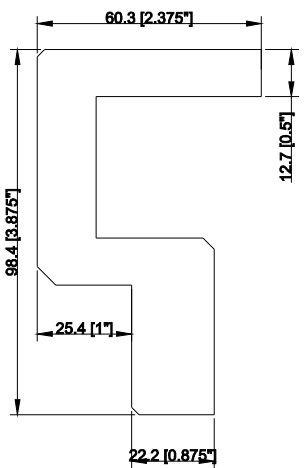

Mission Sill Cap (D/HS)

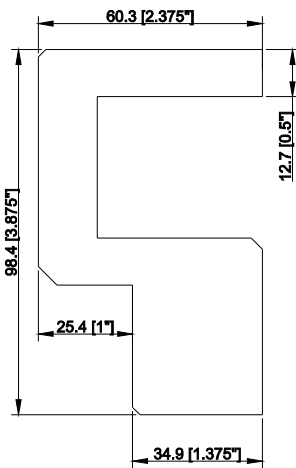

Mission Sill Cap (L)

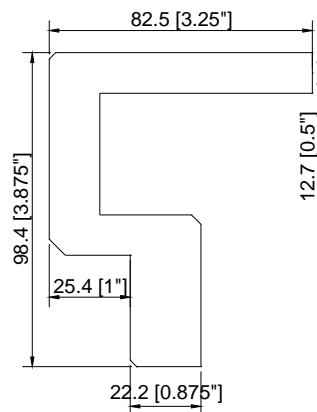

Mission Sill Cap (Z)

Note: For Mission Sill Cap, the extended size at each side needs to be 1" at least.

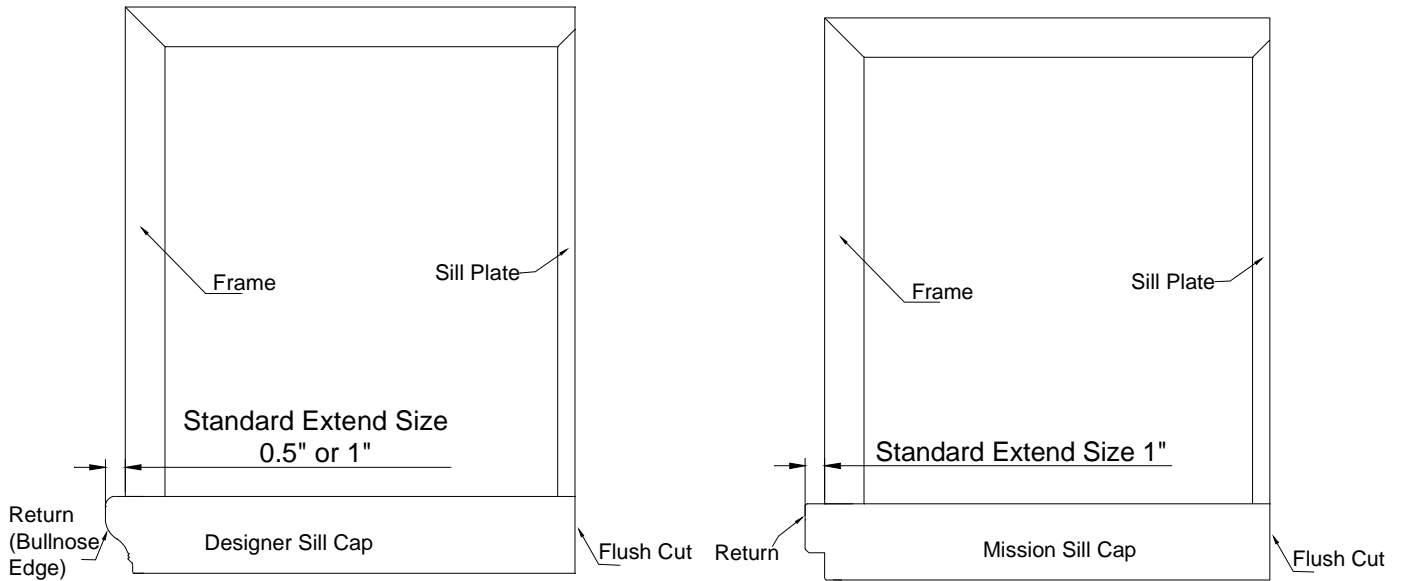

Please note that by **DEFAULT**: the **Designer Sill Cap** will be flush-cut and will not have a **Return (bullnose edge)** on the side(s) of the shutter that has a **Sill Plate** at the left and/or right side(s).

Please note that by **DEFAULT**: the **Mission Sill Cap** will be flush-cut and will not have a **Return** on the side(s) of the shutter that has a **Sill Plate** at the left and/or right side(s).

Left side frame situation	Right side frame situation	Judge extend size on each side for Designer Sill Cap & Mission Sill Cap	Notes
Frame	Frame	Calculation= (Existing sill width + 0.625" x 2 - MFF width) / 2	When the customer indicates the existing sill width for the Designer Sill Cap, and the custom extended sill width is less than the standard: ½" extend on each side (after calculation), then the standard ½" extend on each side will be used.
Frame	Sill Plate	Calculation= Existing sill width + 0.625" - MFF width	
Sill Plate	Frame	Calculation= Existing sill width + 0.625" - MFF width	When the customer indicates the existing sill width for the Mission Sill Cap, and the custom extended sill width is less than the standard: 1" extend on each side (after calculation), then the standard 1" extend on each side will be used.
Sill Plate	Sill Plate	Close the <u>Existing Sill Width</u> field	Designer Sill Cap & Mission Sill Cap will be flush cut on both ends

### Sill Plates- Used with existing sills

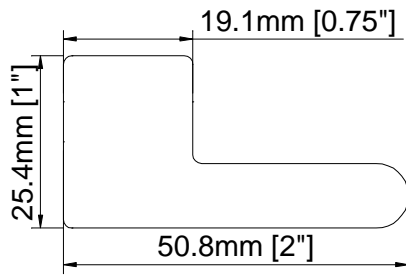

2" Sill Plate with 5/8" Light Block (L/Z)

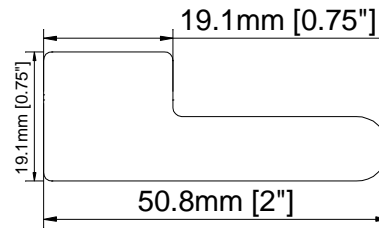

2" Sill Plate with 3/8" Light Block (L/Z)

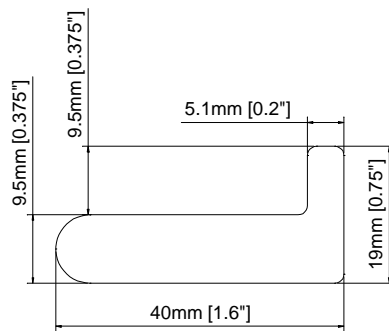

1.6" Sill Plate with 3/8" Light Block

(All Deco & L frames with 1/4" light block)

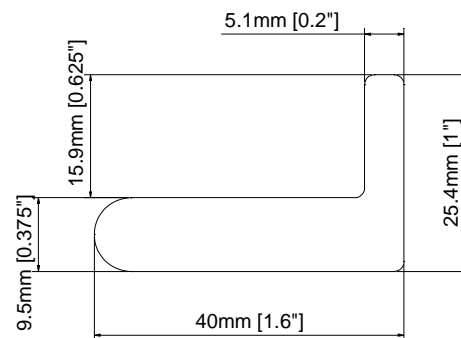

1.6" Sill Plate with 5/8" Light Block

(All Deco & L frames with 1/4" light block)

For 1.6" / 2" sill plate with 5/8" (or 3/8") light block:

- Regular shutters: Available for top sill and bottom sill on 2-sided and bottom sill on 3-sided;
- 3 sides Inverted frame: these sill options can be used at the top only.
- Café shutters: Available for bottom sill;
- Specialty shutters: Not available for shapes below:

Eyebrow Sunburst, Elongated Eyebrow Sunburst, Half Round Sunburst, Half Round w/ Horizontal Louvers, Left Quarter Round Sunburst, Right Quarter Round Sunburst;

Hexagon, Octagon, Circle, Oval;

Peaked w/ Horizontal Louvers, Peaked Sunburst and French door.

For 1.6" / 2" sill plate with 5/8" (or 3/8") light block, when an extended sill plate is requested, the excess width will be divided evenly on both sides, take the following drawing as an example for reference:

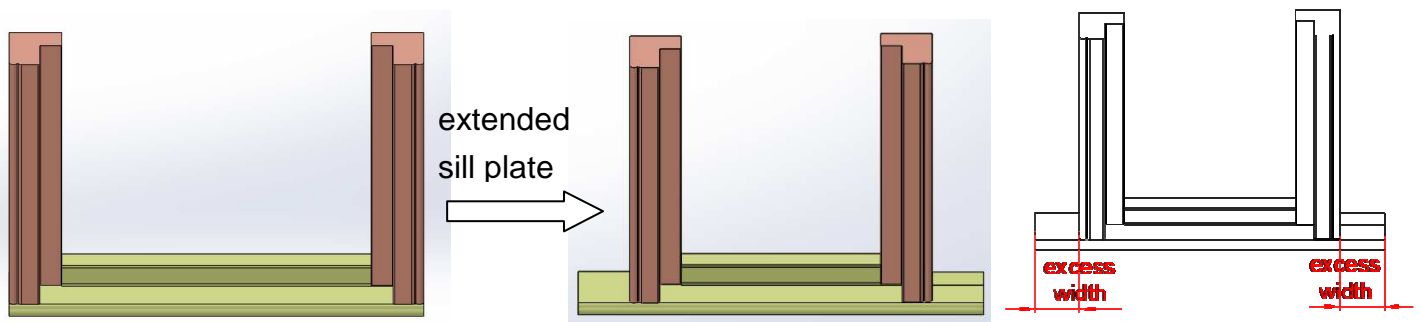

\*Some surcharges apply

Pre-drill L Frames (Inside Mount Only) or Z frames:

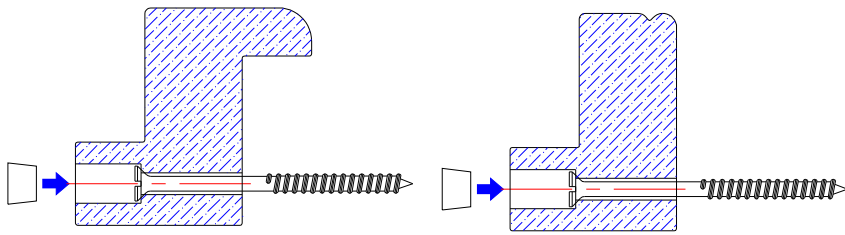

Please note that the prefilled hole and the plug will not be a 100% complete fit, but that would not affect the performance of the screw. Shutters can't be remade solely because of this issue.

Extension for Deco Frame\* (Default to have full extension):

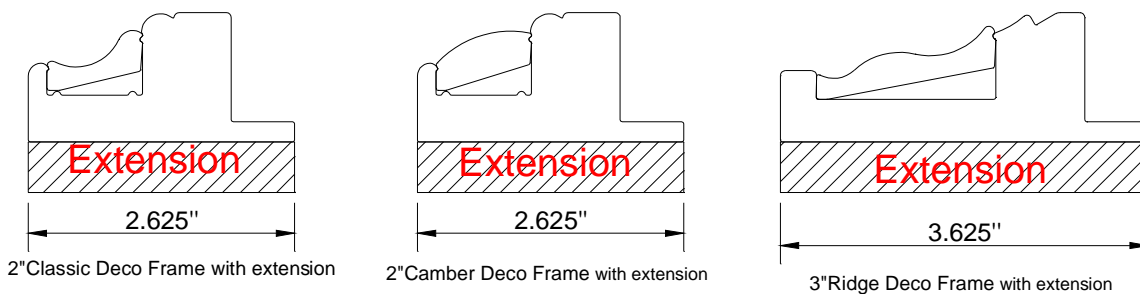

Note: Custom extensions\* are available for Deco Frames, L frames & Hang strips (OM, beside the panel) & T posts, when the extension thickness is more than 2", the extension will not be attached to the frames and/or T posts.

Custom extensions\* are available for the lips of all Z frames except Tilt out Z frames, when the extension thickness is more than 1", the extension will not be attached to the Z frames.

The extension can be on all sides of the frame, or individual sides can be selected if the extension is not needed on all sides.

See the following drawings below as examples:

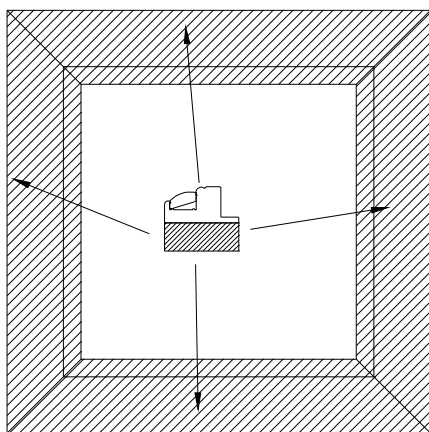

4 sides frames with xxx" full extension

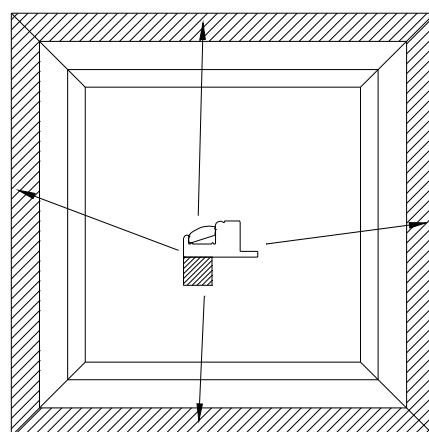

4 sides frames with xxx"wide extension, flush with outside edge of frame

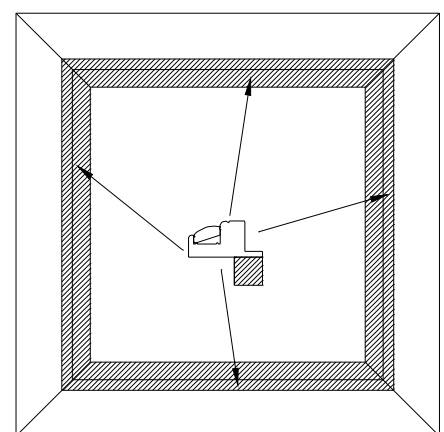

4 sides frames with xxx"wide extension, flush with inside edge of frame

\*Some surcharges apply



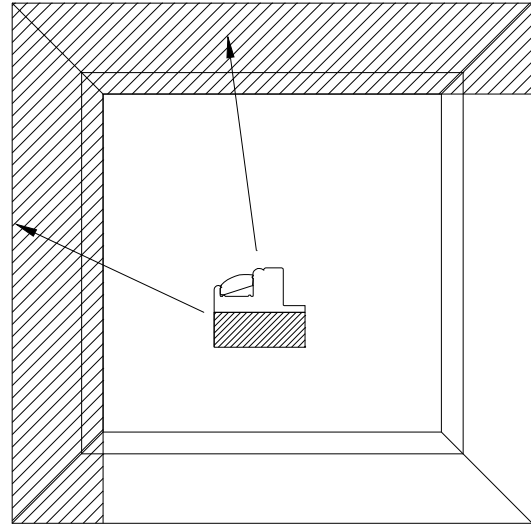
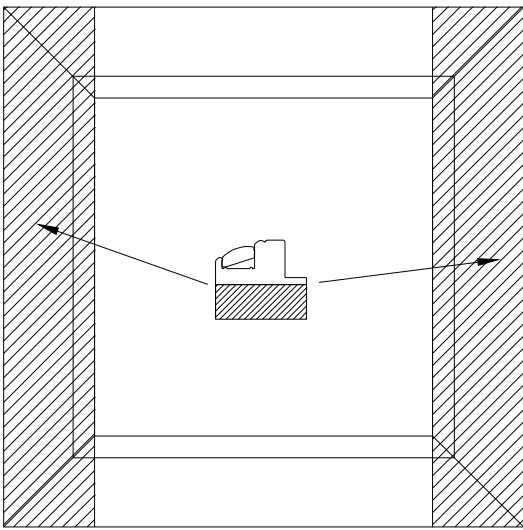

Left and right frames with xxx" full extension

Left and top frames with xxx" full extension

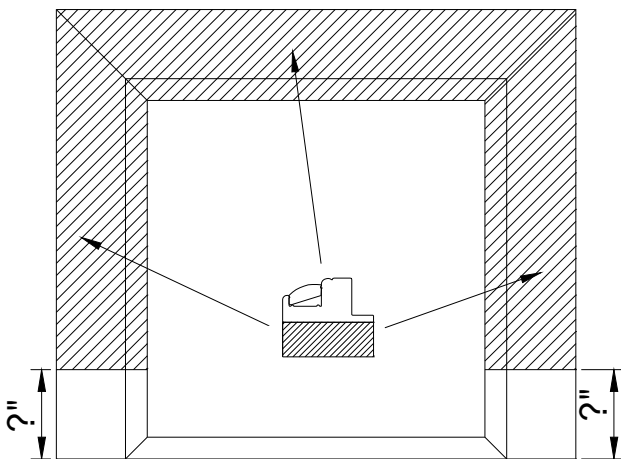

xxx" full extension of left and right frames  
start from "?", no extension on bottom frame

Notes:

- Add extension side (e.g. left, right, top, bottom) to distinguish.
- Add frame location (e.g. left, right, top, bottom) to instead of No. of sides to distinguish.
- Apply to regular shutters and café shutters.
- Apply to all frame types except Hang Strip (behind panel) and Tilt Out Z frame.
- For non-full extension size, please state that the extension is flushed with outside / inside edge of frame.
- When there are tiles or obstacles that prevent all sides of frame to add extension, please state that where to start adding the extension.

● Standard Filler Strips (width x depth):

1" x 3/4"	1" x 2 15/16"	3/4" x 1 1/2"
1" x 1 3/16"		1" x 1 1/2"
1" x 1 9/16"	3/16" x 1 1/2"	1 3/16" x 1 1/2"
1" x 2"	3/8" x 1 1/2"	1 3/8" x 1 1/2"
1" x 2 3/8"	9/16" x 1 1/2"	1 9/16" x 1 1/2"

Note:

1. The width or depth of Custom filler strip / Standard filler strip can't be less than 1/8".
2. The width or depth of Custom filler strip / Standard filler strip can't be greater than 7 7/8".
3. The width and depth of Custom filler strip / Standard filler strip can't be greater than 3 15/16" at the same time.

Notch out\*:

- L Frame
- T Post

Specify dimensions in special instruction box.

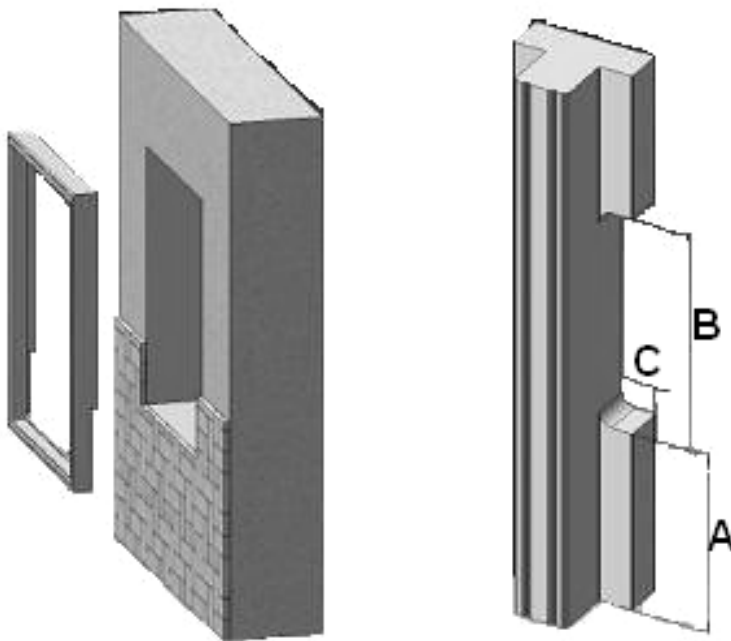

### Uneven Panel Width:

Take Beaded L Frame outside mount as an example:

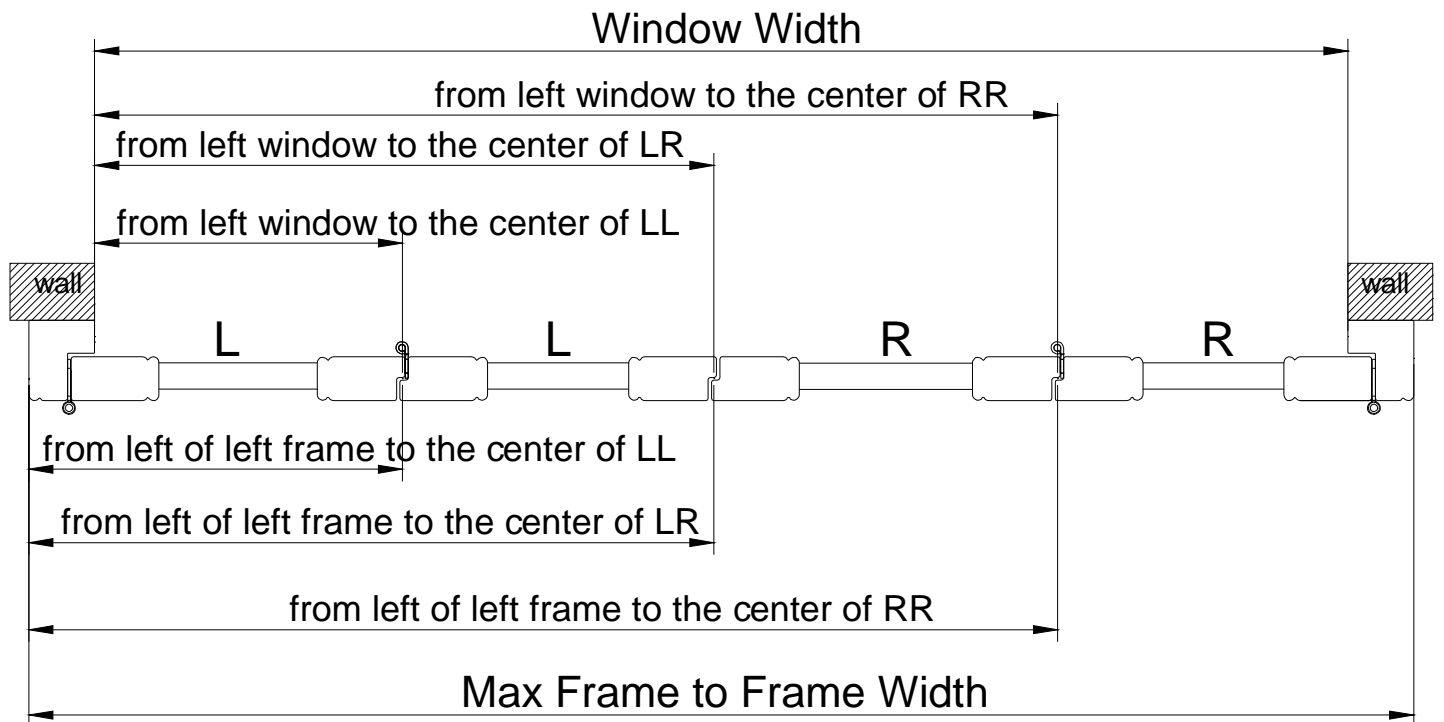

### Default principle:

1. Regarding shutter with horizontal T-post type issue: Horizontal T-Post type will always be the Chamfer T post unless otherwise specified.
2. For Double Hung shutter with a horizontal T post, the face width of the horizontal T post defaults to 1 3/4".

## General Product Specifications

<u>Description</u>	<u>Minimum</u>	<u>Maximum</u>
Single Panel Width (Regular)	6"	30" for 1 7/8" louver 36" for 2 1/2" & 3" louver 42" for 3 1/2" & 4 1/2" louvers
Single Panel Width (Bi-fold)	6"	26"
Single Panel Width (Bi-fold Track)	6"	26"
Single Panel Height	10"	132"
Shutter Width (Without T Post)	N/A	4x single panel width (bifold) + frame
Shutter Width (With T Post)	N/A	Unlimited <b>(For orders shipped by sea freight, frames longer than 142 7/8" will be spliced. For orders shipped by air freight, frames longer than 120" will be spliced.)</b>
Shutter Height	N/A	132" + frame

Divider rail is required for panel heights over 78".

Standard divider rail size is 3", Custom Size (3"~7.875") Divider Rail is available with surcharge.

Please note the standard top/bottom rail size should be within 2.75"~6.5". For regular shutters, the step for the rail size is 1/8".

Shutters to be installed where there is no bottom supports are not available.

Shutters without bottom supports may sag and deform, including:

1. Shutters with a bottom gap over 0.1";
2. Shutters with no frame or existing bottom sill to support the panel (or shutter has bottom frame/existing sill, but the panel is frequently left in the open position).

**Side by Side / Match Line Number:**

When **Side by Side** is selected, it is solely to match top or bottom rails and the number of hinges will also be matched when the panel heights are within +/- 2".

**Match with Previous WO#:**

Match with Previous WO# matches the color if available. (Note: Matching rail sizes and louver counts are subject to product specification limitations.)

- For Pure White color and custom colors, color can only be matched for up to 1 year from original order date
- For non-Pure White color and non-custom colors, color can only be matched for up to 5 months from original order date.

## Tilt Rods

### Standard Tilt Rod

**Default Location:** In the middle of the panel on front side (default).

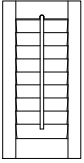

### Offset Tilt Rod\*

**Default Location:** On the front side of the panel and at 1" from the louver ends on the hinged side.

**Optional location:** On the back side of the panel, 1" from the end of the louvers on the hinged side.

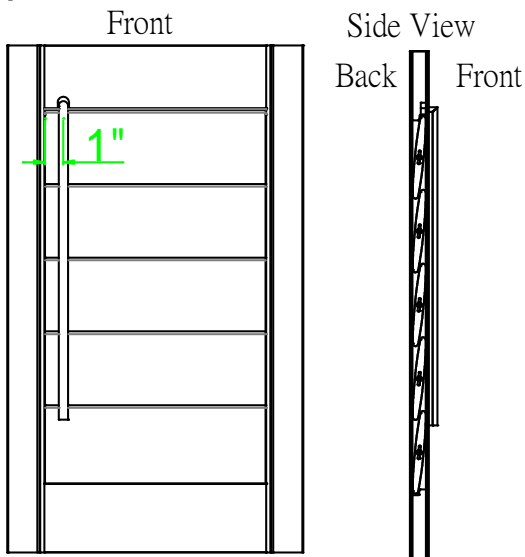

Offset tilt rod on the front side of panel,  
the louvers dress up from front view

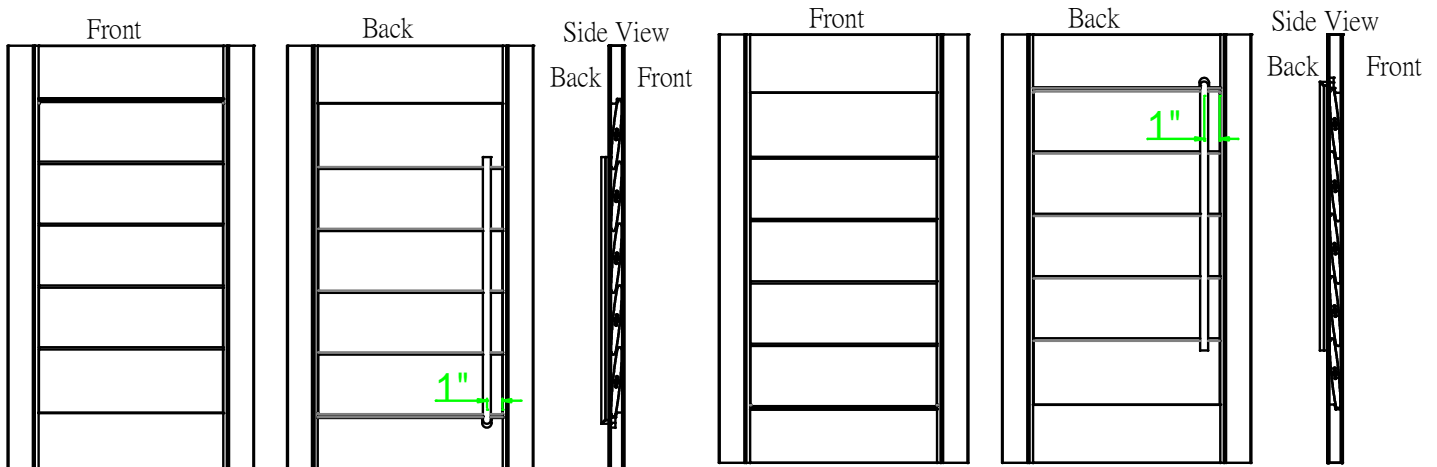

Offset tilt rod on the back side of panel,  
the louvers dress up from front view

Offset tilt rod on the back side of panel,  
the louvers dress down from front view

\*Some surcharges apply

**InvisibleTilt<sup>®</sup> \***

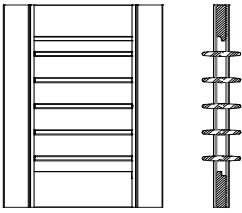

Louver tilting system embedded within panel stile. It is not available for 1<sup>7</sup>/<sub>8</sub>" louver. The tilting system is split when the number of louvers exceeds the limits as listed below:

Louver Size	Maximum Possible Louvers	Panel Height Range
2 <sup>1</sup> / <sub>2</sub> "	24	54 3/4" – 57 1/4"
3"	19	54 1/4" – 57"
3 <sup>1</sup> / <sub>2</sub> "	16	54 3/4" – 58"
4 <sup>1</sup> / <sub>2</sub> "	12	54 3/4" – 60"

For even numbers of louvers, the number of louvers operated by the top and the bottom tilting system will be the same;

For odd numbers of louvers, the number of louvers operated by the bottom tilting system will be one more than the number of louvers operated by the top tilting system;

To ensure split tilt is included, always specify on the order.

### Split Tilt

When selected, the louvers are split equally by default unless a custom location is requested.

When split equally is selected, for odd numbers of louvers, the number of louvers operated by the bottom tilting system will be one more than the number of louvers operated by the top tilting system.

When the customer selects a custom location, the measurement will be as follows (please note that the louvers are in the closed position when measured):

#### Window size:

- Measure from the bottom of the window to the top of the louver

#### Max frame-to-frame:

- Measure from the bottom of the frame (or panel if there is no bottom frame, sill or sill cap) to the top of the louver.

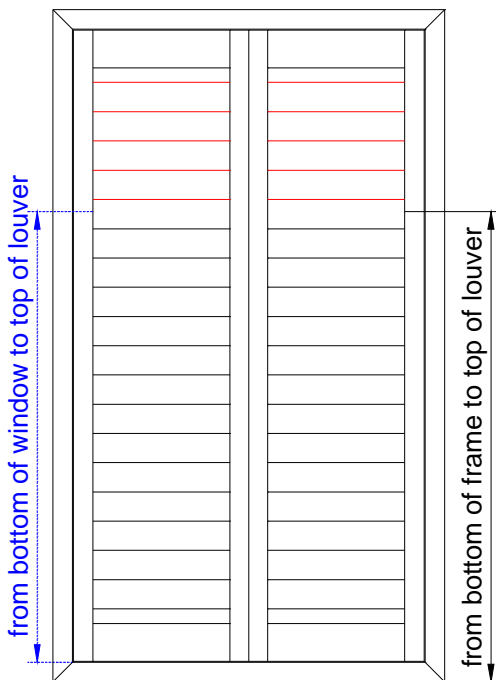

### Split tilt allowable deviations

Louver Size	Allowable ± Deviation
1 7/8"	3/4"
2 1/2"	1"
3"	1 1/4"
3 1/2"	1 1/2"
4 1/2"	2"

### Split Location:

— Per the customer's specification. However, the location of the top louver of the bottom split section may be adjusted to achieve more balanced top and bottom rails when **allow deviations** is selected during order entry. If necessary the location will be moved up from the desired height to ensure any obstruction is covered. The amount of the deviation from the desired height will depend on the size of the louver selected.

If the exact location of the split is critical, customer may select **exact location** in the order entry system when placing the order. This may result in significantly different top and bottom rails. When exact location is selected, a popup will reveal the resulting top and bottom rails measurements from which the customer may either:

1. Accept the listed top and bottom rail sizes
2. Modify the split location (sometimes a slight adjustment in the exact split location may achieve desired top and bottom rail sizes)
3. Change to **allow deviations** so the system will calculate the split location

**Note:** Top and bottom rail sizes may change if the current line item is being matched with another line item. Carefully review all top and bottom rail sizes and split locations to ensure a desirable look is achieved

- **Please note that Tilt options (including tilt rod), Split Tilt, Divider Rail, Double Hung, and PerfectTilt™ motorization are not available for panels with one louver. In addition, there will be no mouse hole on a panel or louver section that has only one louver.**

Panels with one louver may be any of the following:

- a. only one louver on the panel;
- b. only one louver above or below a divider rail;
- c. only one louver above or below a split tilt location;
- d. only one louver on Double Hung top panel or Double Hung bottom panel.



## Divider Rails

A divider rail is an extra rail in the middle of the panel.  
Creates two sections in the panel so louvers can be operated independently.  
Strengthens the panel and enhances structural integrity.

Divider rails is required for panel heights over 78"

For tall panels, the divider rail location should be placed within the panel height maximum, so that the remaining panel space above or below the divider rail is not taller than the panel height maximum. If the divider rail is placed too high or too low on the panel, then a 2nd divider rail may be required.

Custom Size(3"~7.875") Divider Rail is available with surcharge.

### Specifications

Standard size: 3"

Default location: center of the panel unless specified otherwise

If the Divider Rail Location must be accurate, "Exact Location" must be selected or specified when placing an order.

### Measurements:

- Window size:
  - Measure from the bottom of the window to the center of the divider rail.
- Max frame-to-frame:
  - Measure from the bottom of the frame to the center of the divider rail.
- Position:
  - Per customer's specification. However, the divider rail may be adjusted to a lower or higher position, within our allowable deviation, to ensure reinforcement and aesthetics of the shutter.

When placing the order, please clearly specify if the divider rail position needs to line up with that of other shutter divider rails in the same room. Please also refer to the table below for the allowable deviation details.
- Between 2 divider rails / 2 split tilt rod locations / 1 divider rail location and 1 split tilt location, there needs to have at least two or more louvers for non-motorization shutters.

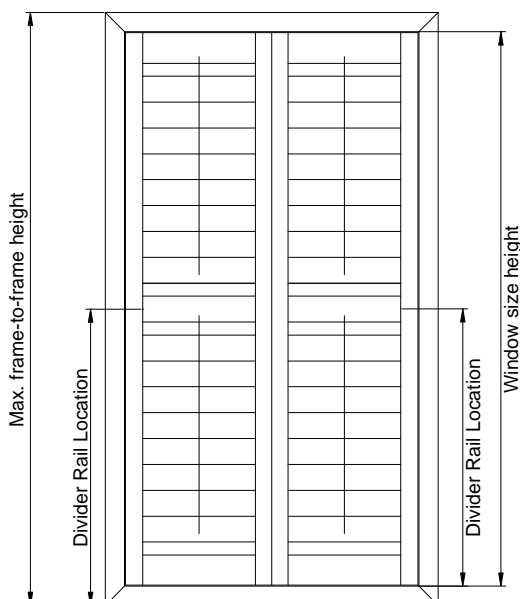

### Divider rail allowable deviations

Louver Size	Allowable $\pm$ Deviation
1 $\frac{1}{8}$ "	$\frac{3}{4}$ "
2 $\frac{1}{2}$ "	1"
3"	1 $\frac{1}{4}$ "
3 $\frac{1}{2}$ "	1 $\frac{1}{2}$ "
4 $\frac{1}{2}$ "	2"

## Hardware

### Hinges

**2.375" Self-Mortise Hinge**

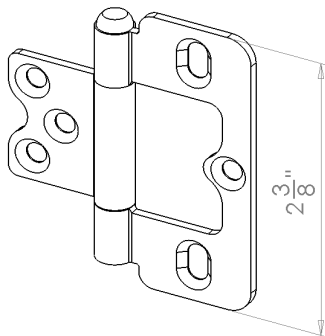

**2.375" Bi-fold Hinge**

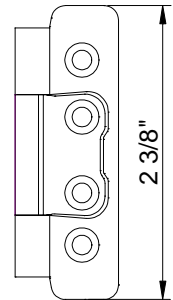
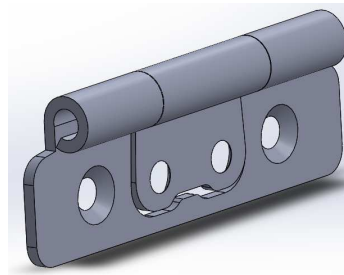

**2.375" L Hinge**

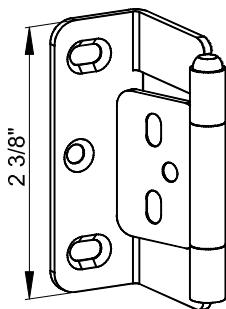

**Direct Mount 3" Hinge**

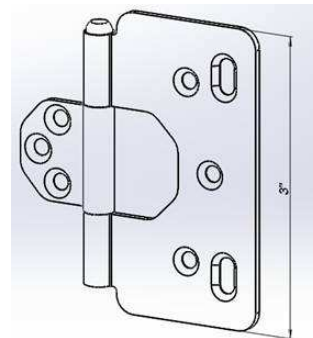

Hinges are available in:

Pure White, Silk White, Bisque, Pearl, Bright Brass, Antique Brass, Black, Nickel plated, Brushed Nickel, Stainless Steel\*, Crisp Linen, String, Sea Mist, Stone Gray, Brown Gray, Taupe Gray.

While hinge colors of Crisp Linen, String, Sea Mist, Stone Gray, Brown Gray, Taupe Gray are not available for Direct mount 3" Hinges.

False hinges are not available.

➤ **Direct Mount 3" Hinge:**

1. The hinge position of the direct mount 3" hinge will be different from that of the 2.375" ones. For shutters used both the 2.375" and the direct mount 3" hinge, the hinge position of the 2.375" ones will match that of the direct mount 3" hinge;
2. The hinge is only to install between the panel and the existing window. For other situation, 2.375" hinges will be used;

\*Some surcharges apply

3. To avoid conflict, there will be cut-out for the light block of the hinged side. Please refer to the drawing below.

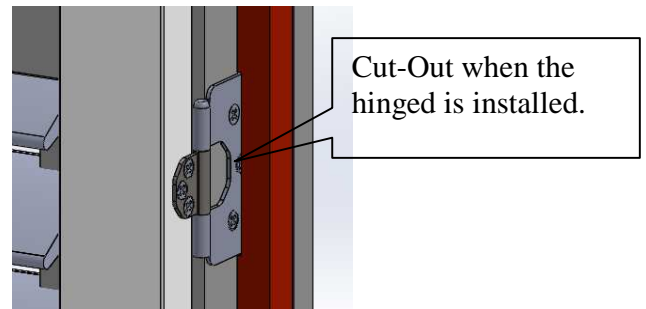
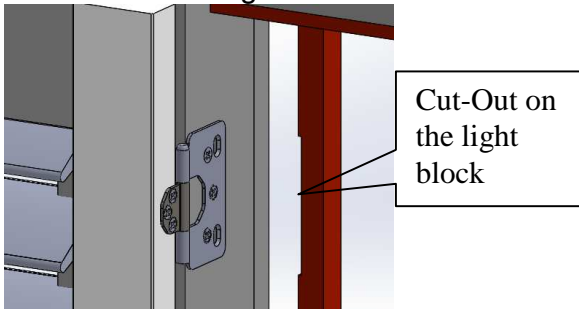

4. Direct Mount 3" Hinge is not suitable for drywall installations.

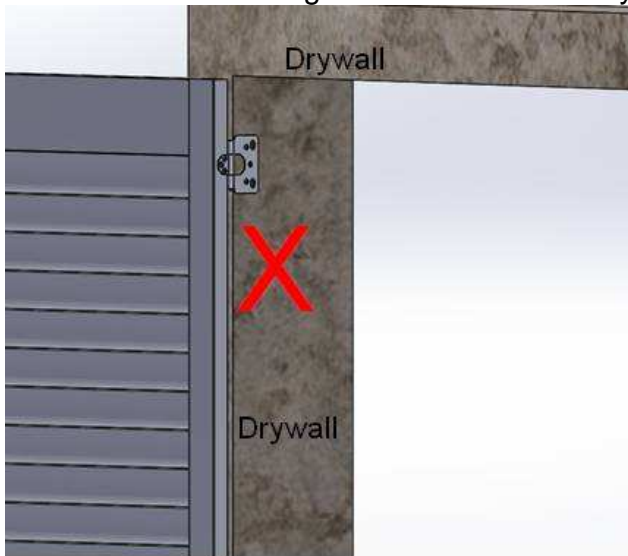

Direct Mount 3" hinge is not suitable for drywall installations.  
It's not recommended.

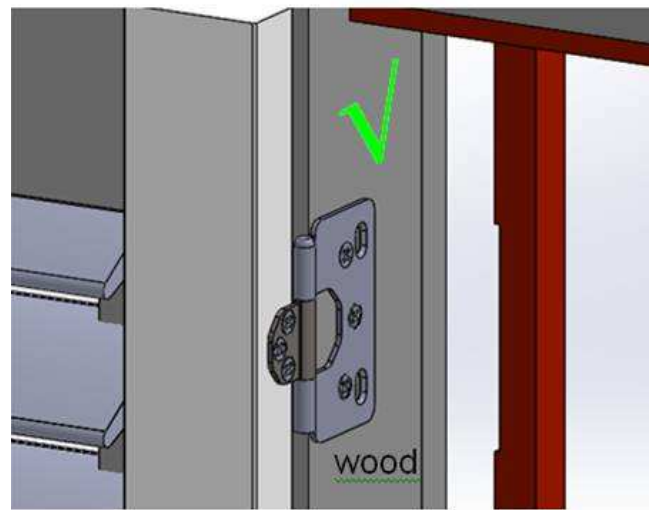

It's acceptable.

### Invisible Hinge\*:



1. Invisible hinge is not available for multifold panels.
2. Invisible hinge can only be between the panel & frame/T post, connections from panel to panel will use a regular hinge.
3. Color Option: Only available for Pearl Chrome Plated.
4. The invisible hinge is not available with the following specialty shapes: Circle w/ horizontal louvers, Circle sunburst, Oval w/ horizontal louvers, Type E 60 degree French door cutout, and Type F rectangular French door cutout.

\*Some surcharges apply

Frame Options	Hinge	Notes
2" Camber Deco Frame	Y	/
2" Classic Deco Frame	Y	/
2.5" Mission Deco Frame	N	/
3" Ridge Deco Frame	N	/
Vintage L Frame W / 1/4" Light Block	N	/
Vintage L	N	/
Vintage L Frame w/ 1/2" Buildout	N	/
Vintage L Frame w/ 1" Buildout	N	/
Beaded L w 1/4"light block	Y	/
Beaded L	Y	/
Beaded L Frame w/ 1/2" Buildout	Y	/
Beaded L Frame w/ 1" Buildout	Y	/
Tilt out Z Frame	N	/
1.25" Beaded Z Frame	Y	/
1.5" Bullnose Z Frame	Y	/
2" Bullnose Z Frame	Y	/
2" Bel Air Z Frame	Y	/
3" Crown Z Frame	N	/
7/8" Vintage Hang Strip	N	/
1" Chamfer T-Post w/ 1/4" Light Block(for Deco)	Y	only available with hinge on one side, for example, LTL is available, but RTL is not.
1" Chamfer T-Post w/3/4" Light Block(for L/Z/HS)	Y	
1" Chamfer T-Post w/ 1/4" thick 3/8" wide Light Block(for Deco)	Y	
1" Chamfer T-Post w/3/4" thick 3/8" wide Light Block(for L/Z/HS)	Y	
1 3/4" Chamfer T-Post w/1/4" Light Block(for Deco)	Y	available with hinge on BOTH side, for example, RTL.
1 3/4" Chamfer T-Post w/3/4" Light Block(for L/Z/HS)	Y	
Corner Post w/1/4" Light Block(for Deco)	Y	/
Corner Post w/3/4" Light Block(for L/Z/HS)	Y	/
Bay Post w/1/4" Light Block(for Deco)	Y	/

Bay Post w/3/4" Light Block(for L/Z/HS)	Y	/
Slim Fit Corner Post for 90 Degree(L/Z/HS)	N	
Slim Fit Corner Post for 90 Degree(D)	N	
Slim Fit Bay Post for 135 Degree(L/Z/HS)	N	
Slim Fit Bay Post for 135 Degree(D)	N	
Slim Fit Bay Post for 150 Degree(L/Z/HS)	N	
Slim Fit Bay Post for 150 Degree(D)	N	

Invisible Hinge Qty	
Panel Height (H)	Hinge Qty
H<=48"	2
48"<H<=78"	3
78"<H<=96"	4
96"<H<=120"	5
H>120"	6

**Preinstallation:**

Panels and frames will be packaged individually, and the hinge is preinstalled onto the frame/post, with the screws for the other half part on the panels in the hardware box.

Note: If Custom T-posts need to install Invisible Hinge, the size of Custom T-post face width plus one side light block width can't be more than 4 5/8"; Please see drawing for reference.

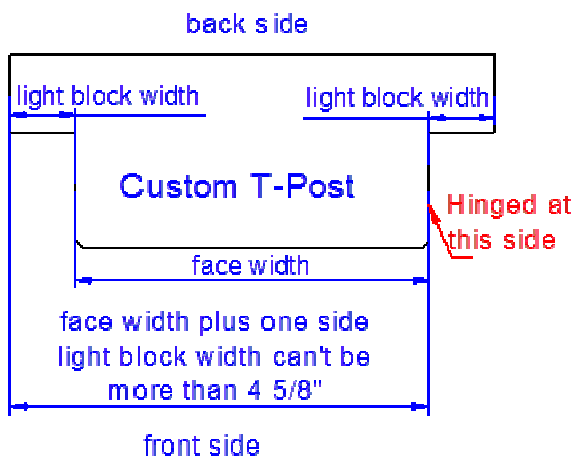

## Installation Instructions for the Invisible hinges

Take L Frame as an example:

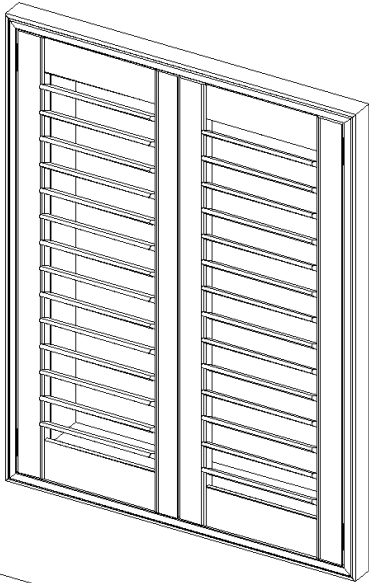

- 1). Remove the corresponding panels and frames from their packaging and match the panels with the correct frames.

Install the frames on the corresponding windows and make sure they are square (diagonals are equal)

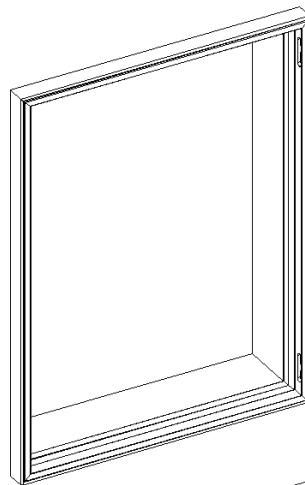
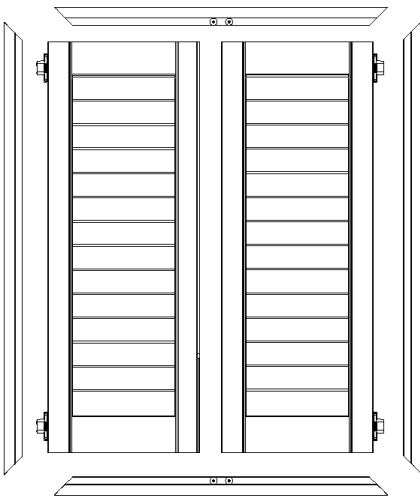

- 2). Please insert **ALL** of the Invisible hinges on the panel into the hinge holes on the corresponding frames prior to trying to secure any single hinge. This may require the assistance of a second person to hold the panel to prevent the hinges from sliding out of their slots while the screws are secured (Do not let the panels hang from just one hinge).

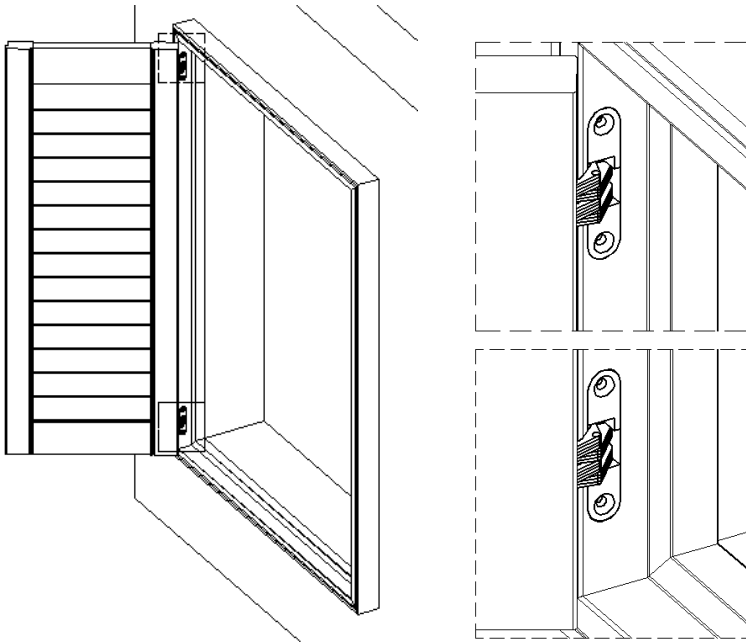

3). To properly secure the panels, first please tighten the upper screw of the uppermost top hinge and the lower screw of the lowest hinge. Close the panel to check whether the shutter closure is normal and the gap is uniform.

**Note:**

- a) When locking the screw, again it is important to prevent the invisible hinges from sliding out of their slots.
- b) Only the screws provided in the hardware box may be used and they cannot be replaced by other screws.

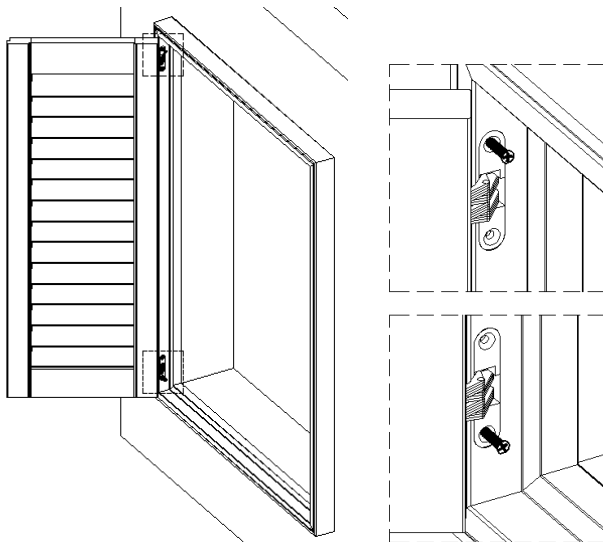

4). When the closure gap is uniform, secure the remaining screws.

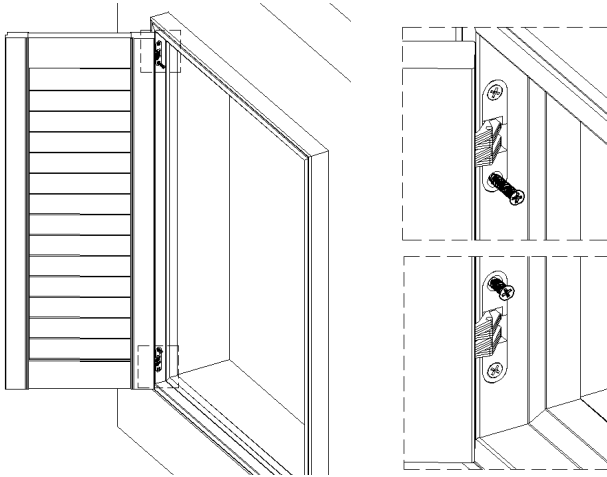

5). Install the remaining panels in the same manner.

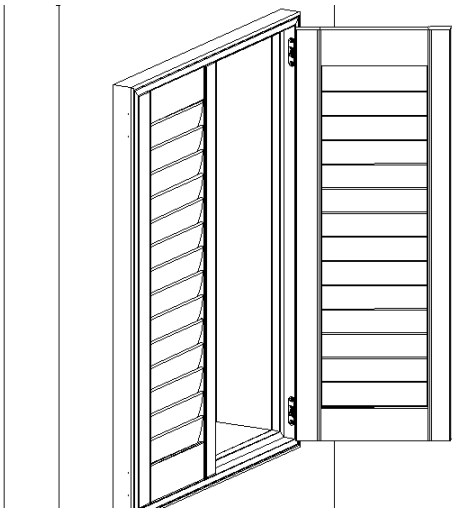

Panel Lock: (not available for 1.625" Stile)

Available Material: All

Color: Brush Nickel Plated, Pure White, Pearl, Black.

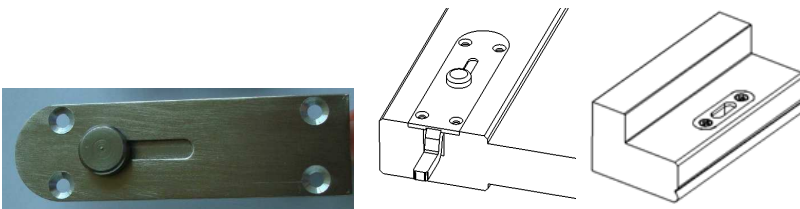

Position:

- Only available on Bottom for Track Shutters with Bottom Track.
- For Regular, available on Top/Bottom/both Top and Bottom.
- Café shutters can only have a panel lock at the bottom.
- Specialty shapes with a straight edge across the top or bottom may have a panel lock at top or bottom.

\*Some surcharges apply



- Specialty shapes with the hinges on the bottom cannot have a panel lock at the bottom. Specialty shapes that are able to have the hinges at the bottom are:  
 Eyebrow Sunburst, Elongated Eyebrow Sunburst,  
 Half Round Sunburst, Half Round with Horizontal Louvers,  
 Left Quarter Round Sunburst, Right Quarter Round Sunburst,  
 Peak Sunburst, Peak Sunburst with Horizontal Louvers,  
 Sunburst on Top with Divider Strip-top section,  
 Sunburst on Top with T Post-top section,  
 Arch Top Picture Window with Sunburst-top section,  
 Sunburst Louvers Center Arch with Quarter Round Side Panels-top section  
 Standard Unit with Horizontal Arch Center-top section.

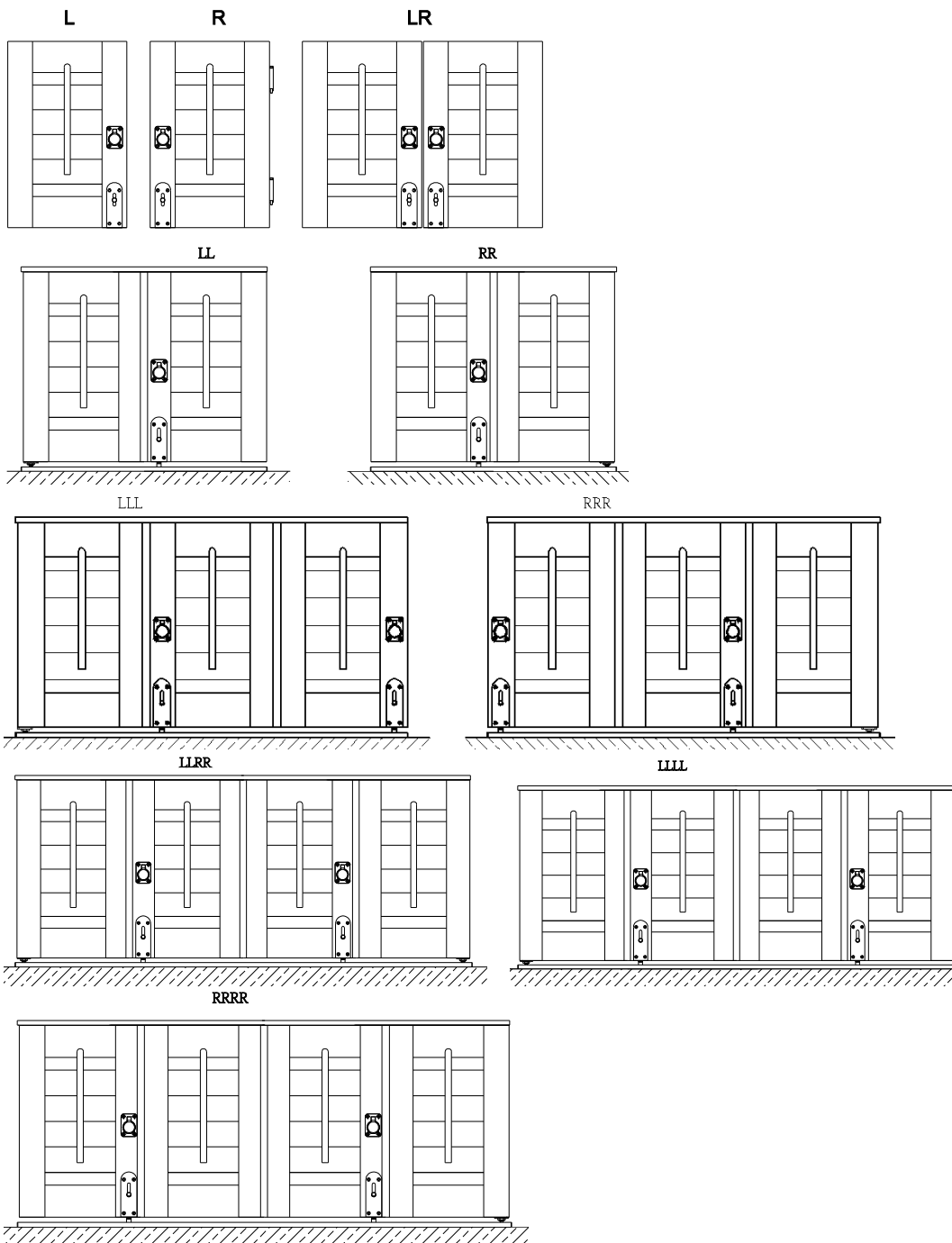

\*Some surcharges apply

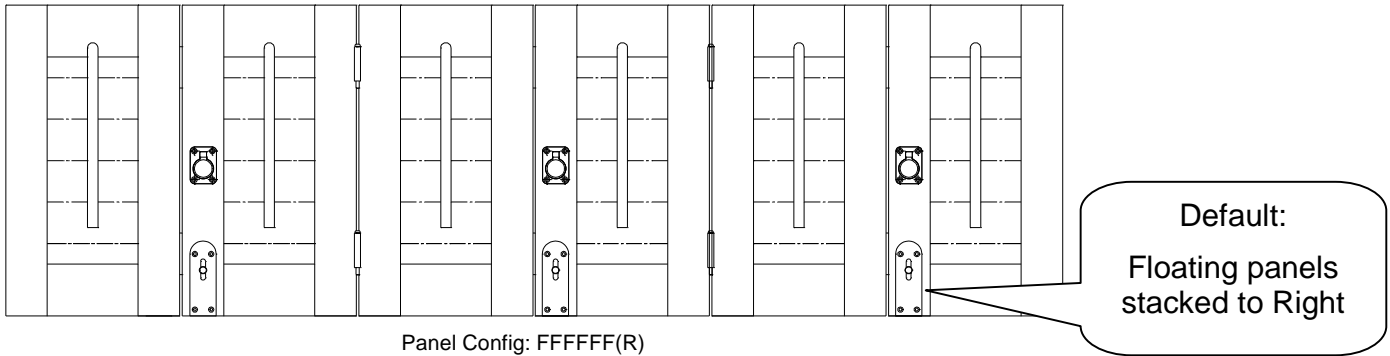

The Panel Lock location for both track system shutters and regular shutters would be the same. The general principle is that the Panel Lock position will avoid the stile which will install the spring-loaded guide at bottom (same stile as the Wheel carrier).

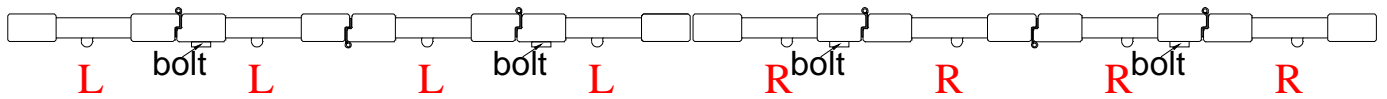

Ring pull: for easy opening and closing. (Not available for 1.625" Stile)

Available in all shutter programs.

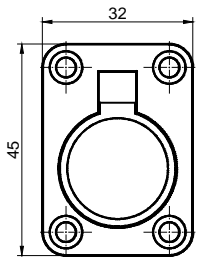

Handles (Not available for 1.625" Stile):

Available in all shutter programs.

Handle color options: White, Pearl, Black, Brushed Nickel.

Curved Hidden Handle & Rectangle Hidden Handle (for non Bypass track shutter)

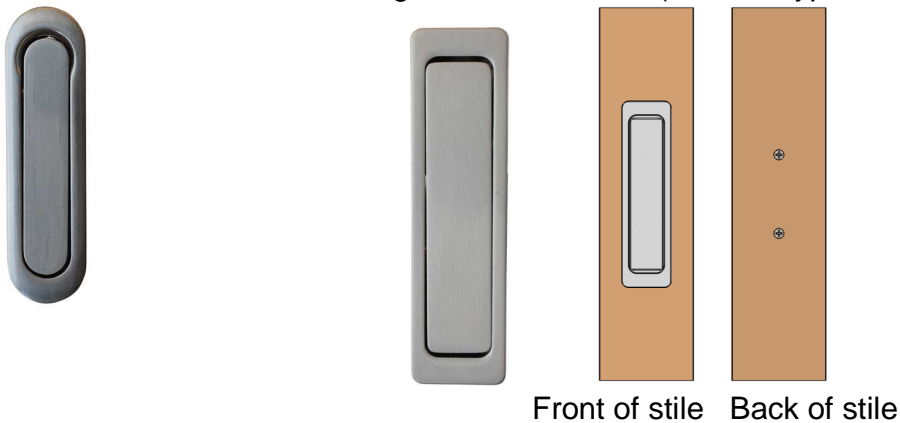

\*Some surcharges apply

Ring pull, Curved hidden handles and rectangular handles are not available for the following specialty shapes.

Eyebrow Sunburst, Elongated Eyebrow Sunburst, Half Round Sunburst, Half Round w/ Horizontal Louvers, Left Quarter Round Sunburst, Right Quarter Round Sunburst;

Hexagon, Octagon, Circle, Oval;

Peaked w/ Horizontal Louvers and Peaked Sunburst.

Recessed Handle (for Bypass track shutter)

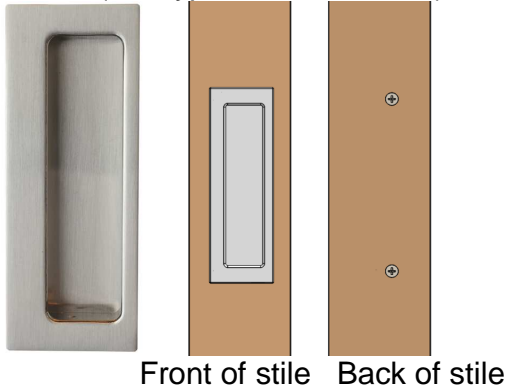

**Ring pull & Curved Hidden Handle & Rectangle Hidden Handle location principle for Floating Panels:**

1. When floating panel config is in pairs, it will be split into halves, the left will be for LL and the right will be for RR. So the ring pull / Curved Hidden Handle / Rectangle Hidden Handle location for FF/FF, FF/FF/FF/FF will be same as that of panel config as LL/RR, LL/LL/RR/RR.
2. When floating panel config is FF, the ring pull / Curved Hidden Handle / Rectangle Hidden Handle location will be same as that of panel config LL.
3. When floating panel config is FFFF/FF, the ring pull / Curved Hidden Handle / Rectangle Hidden Handle location will be same as that of panel config LLLL/RR.
4. When floating panel config is singular, it will be split into 3 sections, the left and mid sections are for LL and the right section is for RR. So the ring pull / Curved Hidden Handle / Rectangle Hidden Handle location for FF/FF/FF, FF/FF/FF/FF/FF will be same as that of LL/LL/RR, LL/LL/LL/RR/RR.

**Recessed Handle location principle for Bypass track shutters:**

Recessed Handle is not available for hinge connected stiles.

Panels on the rear track of an Open Bypass shutter that have panel light block or that have a connecting hinge are not able to have a recessed handle.

Take the following diagrams of the 4 panel side opener with Rabbet stile & 6 panel center opener with Rabbet stile as examples:

4 panels side open w/Rabbet stile

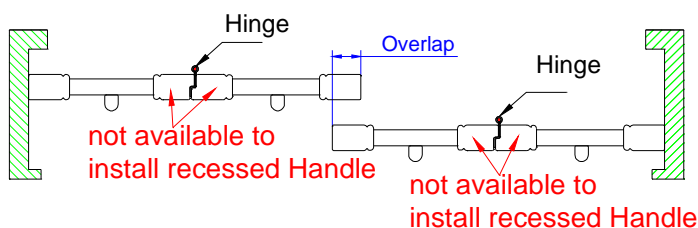

6 panels center open front w/Rabbit stile

not available to install Recessed Handle

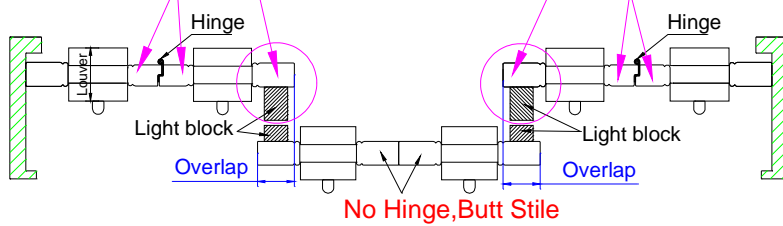

Please note the ring pull / handles color will match with the hinge color.

When shutter order with Invisible Hinge, the ring pull / handles color will match with the normal hinge color.

Please see the matching chart below:

Hinge color	Pure White	Silk White	Bisque	Pearl	Black	Nickel Plated	Brushed Nickel	Antique Brass	Bright Brass	Stainless Steel
Ring Pull color	White	White	Bisque	Pearl	Black	Brushed Nickel	Brushed Nickel	Antique Brass	Bright Brass	Brushed Nickel
Handles color	White	White	Pearl	Pearl	Black	Brushed Nickel	Brushed Nickel	Brushed Nickel	Brushed Nickel	Brushed Nickel

Hinge color	Crisp Linen	String	Sea Mist	Stone Gray	Brown Gray	Taupe Gray
Ring Pull color	Bisque	Bisque	Brushed Nickel	Brushed Nickel	Brushed Nickel	Brushed Nickel
Handles color	Pearl	Pearl	Brushed Nickel	Brushed Nickel	Brushed Nickel	Brushed Nickel

- The ring pull colors and Handles colors are selectable.

**Paint colors (Solid colors) (24) :**

No.	Color ID	Color Name	2.375" Hinge color (Default)	Direct Mount 3" Hinge color (Default)	T post connector color (Default)	Ring pull color (Default)	Curved Hidden Handle / Recessed Handle / Rectangle Hidden Handle color (Default)	Panel Lock (Default)	Invisible hinge color	New Top & Bottom Tracks color (Default)	Dovetail Key Color (Default)
1	001	Pure White	Pure White	Pure White	Pure White	White	White	Pure White	Pearl Chrome Plated	Bright White	White
2	002	Extra White	Silk White	Silk White	Silk White	White	White	Pure White		Bright White	White
3	003	Silk White	Silk White	Silk White	Silk White	White	White	Pure White		Bright White	White
4	004	Bright White	Silk White	Silk White	Silk White	White	White	Pure White		Bright White	White

\*Some surcharges apply

5	006	Pearl	Pearl	Pearl	Pearl	Pearl	Pearl	Pearl	Bright White	White
6	007	Ivory Lace	Pearl	Pearl	Pearl	Pearl	Pearl	Pearl	Metallic Gray	White
7	009	Creamy	Pearl	Pearl	Pearl	Pearl	Pearl	Pearl	Bright White	White
8	012	Crisp Linen	Crisp Linen	Bisque	Bisque	Bisque	Pearl	Pearl	Metallic Gray	White
9	013	Bisque	Bisque	Bisque	Bisque	Bisque	Pearl	Pearl	Metallic Gray	White
10	017	Gray Black	Black	Black	Black	Black	Black	Black	Black	Black
11	019	String	String	Bisque	Bisque	Bisque	Pearl	Pearl	Metallic Gray	Transparent
12	032	Sea Mist	Sea Mist	Nickel Plated	Nickel Plated	Brushed Nickel	Brushed Nickel	Brush Nickel Plated	Metallic Gray	White
13	046	Ice	Silk White	Silk White	Silk White	White	White	Pure White	Bright White	White
14	053	Clay	Nickel Plated	Nickel Plated	Nickel Plated	Brushed Nickel	Brushed Nickel	Brush Nickel Plated	Bronze	Transparent
15	063	Decorator's White	Silk White	Silk White	Silk White	White	White	Pure White	Bright White	White
16	066	Winchester White 2010	Pearl	Pearl	Pearl	Pearl	Pearl	Pearl	Metallic Gray	White
17	076	Aura White	Silk White	Silk White	Silk White	White	White	Pure White	Bright White	White
18	080	Taupe Gray	Taupe Gray	Nickel Plated	Nickel Plated	Brushed Nickel	Brushed Nickel	Brush Nickel Plated	Metallic Gray	White
19	836	Classic Black	Black	Black	Black	Black	Black	Black	Black	Black
20	090	TS White	Pure White	Pure White	Pure White	White	White	Pure White	Bright White	White
21	600	True White	Silk White	Silk White	Silk White	White	White	Pure White	Bright White	White
22	601	Chiffon	Silk White	Silk White	Silk White	White	White	Pure White	Bright White	White
23	603	Natural Linen	Pearl	Pearl	Pearl	Pearl	Pearl	Pearl	Metallic Gray	White
24	609	Chateau Brown	Nickel Plated	Nickel Plated	Nickel Plated	Brushed Nickel	Brushed Nickel	Brush Nickel plated	Metallic Gray	Transparent

~~\*\* The 017 Gray Black, 836 Classic Black and 609 Chateau Brown Colors will have a surcharge.~~

- When the bottom track colors are bright white and metallic gray, the default spring loaded guide color will be white; When the bottom track colors are bronze and black, the default spring loaded guide color will be coffee.
- Please note that the color options for pin/tension gears are White and Coffee. For custom color orders please select either White or Coffee when placing an order.
- For custom color orders, the supplied dovetail keys will match the selected pin/tension gear color (White or Coffee).

\*Some surcharges apply

- For custom color orders, please select the desired T-post connector color from the available options when placing an order.
- For custom color orders with Invisible Hinge, but without Bifold hinge, please select the desired magnet catch (round magnet catch or sill magnet catch or 8.5x25mm magnet catch) color from the available options when placing an order.

Position: For different panel configuration, please refer to the location of Panel Lock to show on which stile the pull will be fixed.

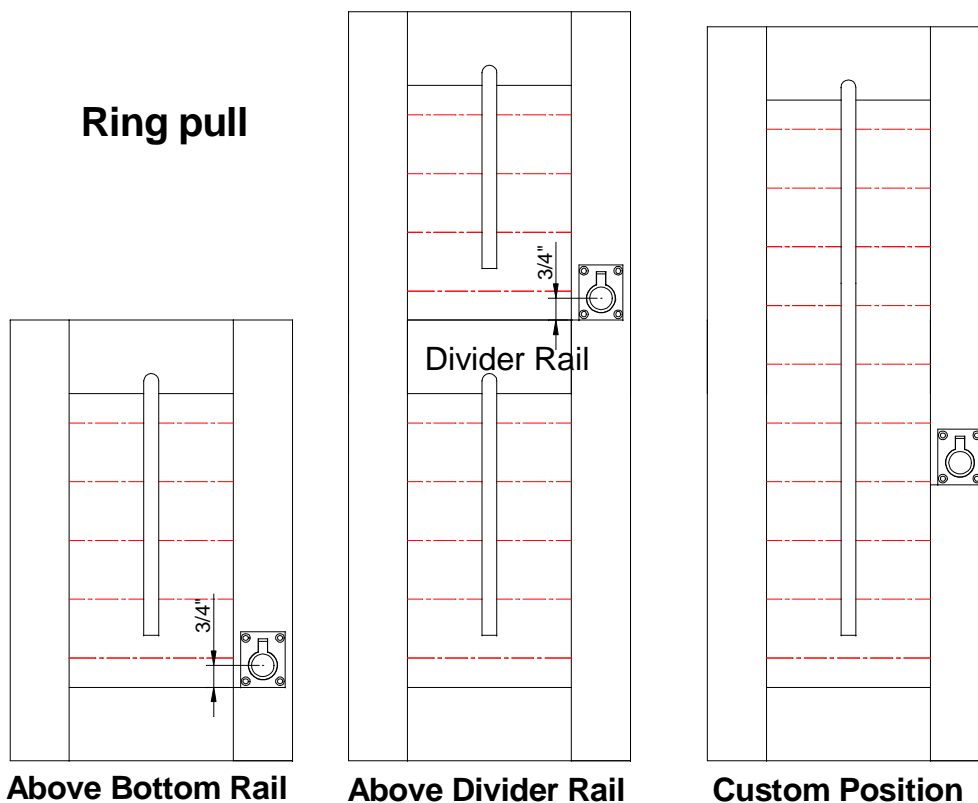

- Position:
- Above Bottom Rail
  - Above Divider Rail / Center of panel
  - Custom Position

If both Panel Lock & ring pull are specified, the distance between them is 2 3/4", and the ring pull location is 6 3/4" from the bottom of panel.

When there is no mid rail, ring pull will be just on the top of Panel Lock (2 3/4" above Panel Lock) as default location; if there are mid rails, bottom of ring pull lines up with top of the 1<sup>st</sup> mid rail as default location.

## Ring pull

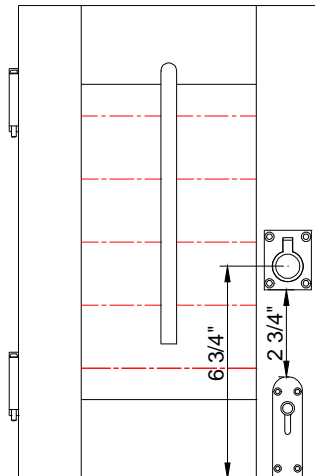

**Above Panel Lock**

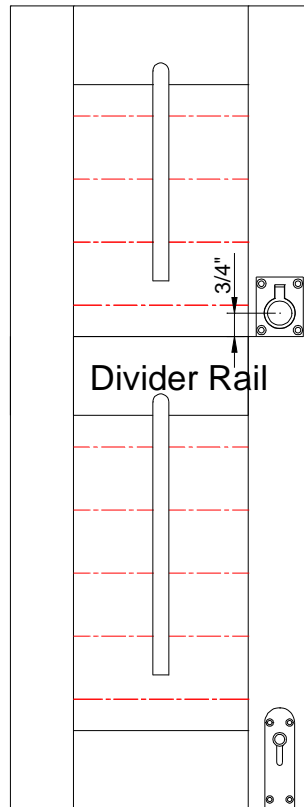

**Above Divider Rail**

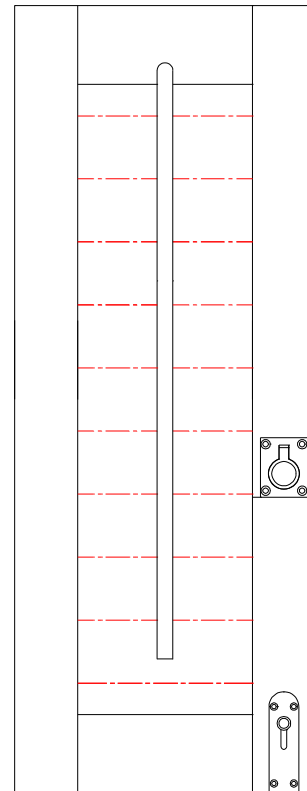

**Custom Position**

Position:

- A. 2 3/4" Above Panel Lock
- B. Above Divider Rail / Center of panel
- C. Custom Position

### Measurements:

- Window size:
  - Measure from the bottom of the window to the center of the ring pull.
- Max frame-to-frame:
  - Measure from the bottom of the frame to the center of the ring pull.

Position: For different panel configuration, please refer to the location of Panel Lock to show on which stile the Handles will be fixed.

**Curved Hidden Handle**

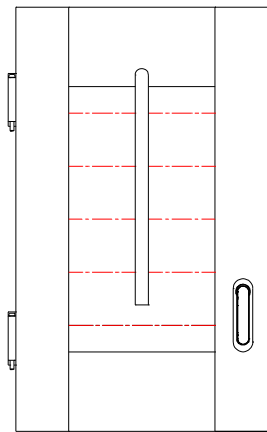

**Above Bottom Rail**

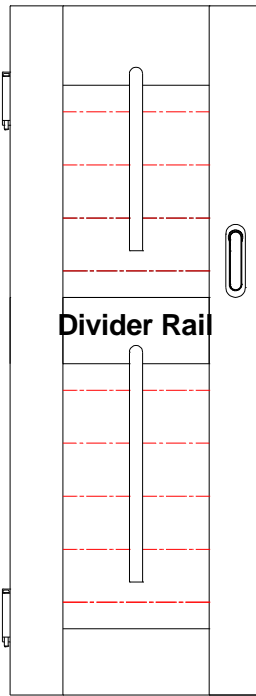

**Above Divider Rail**

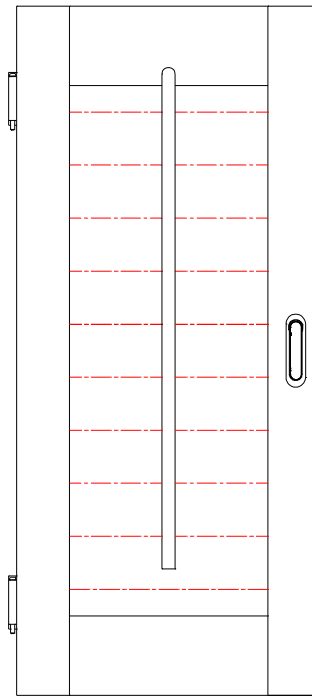

**Custom Position**

**Rectangle Hidden Handle**

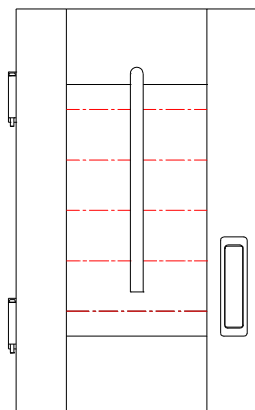

**Above Bottom Rail**

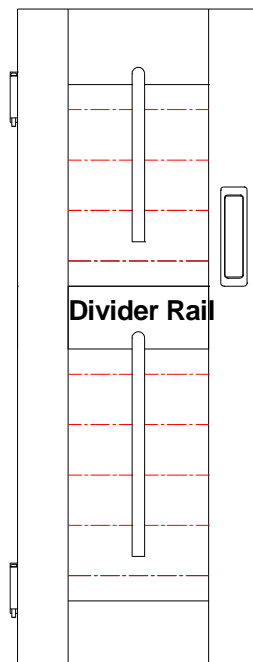

**Above Divider Rail**

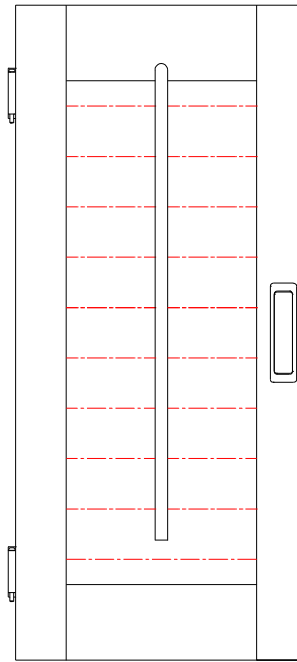

**Custom Position**

Position:

- A. Above Bottom Rail
- B. Above Divider Rail / Center of panel
- C. Custom Position



**Recessed Handle**

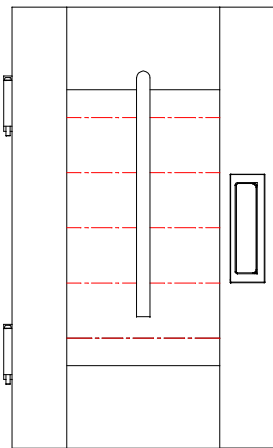

**Center of panel**

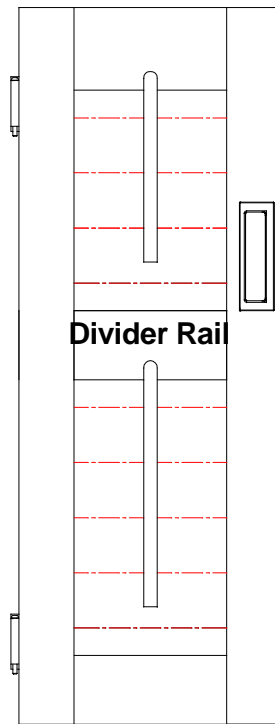

**Divider Rail**

**Above Divider Rail**

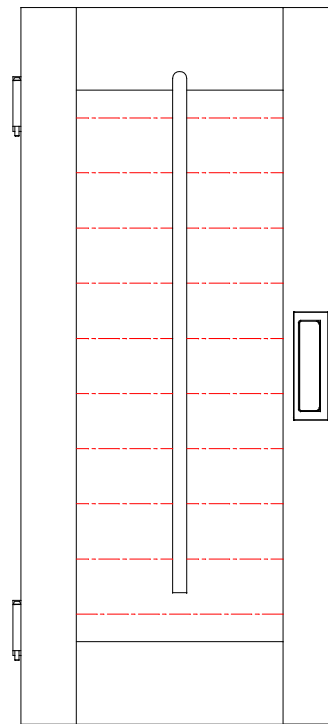

**Custom Position**

Position:

- A. Center of panel
- B. Above Divider Rail
- C. Custom Position

**Curved Hidden Handle**

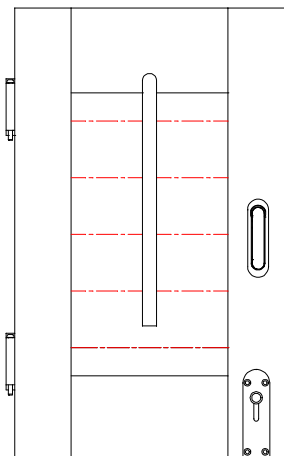

**Center of panel**

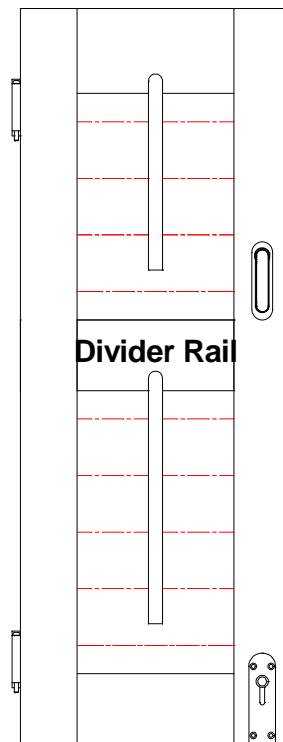

**Divider Rail**

**Above Divider Rail**

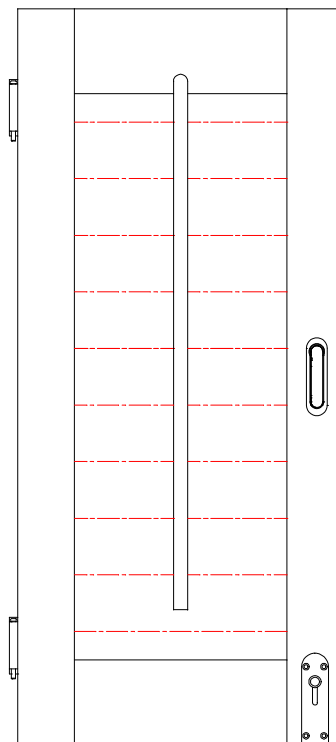

**Custom Position**

## Rectangle Hidden Handle

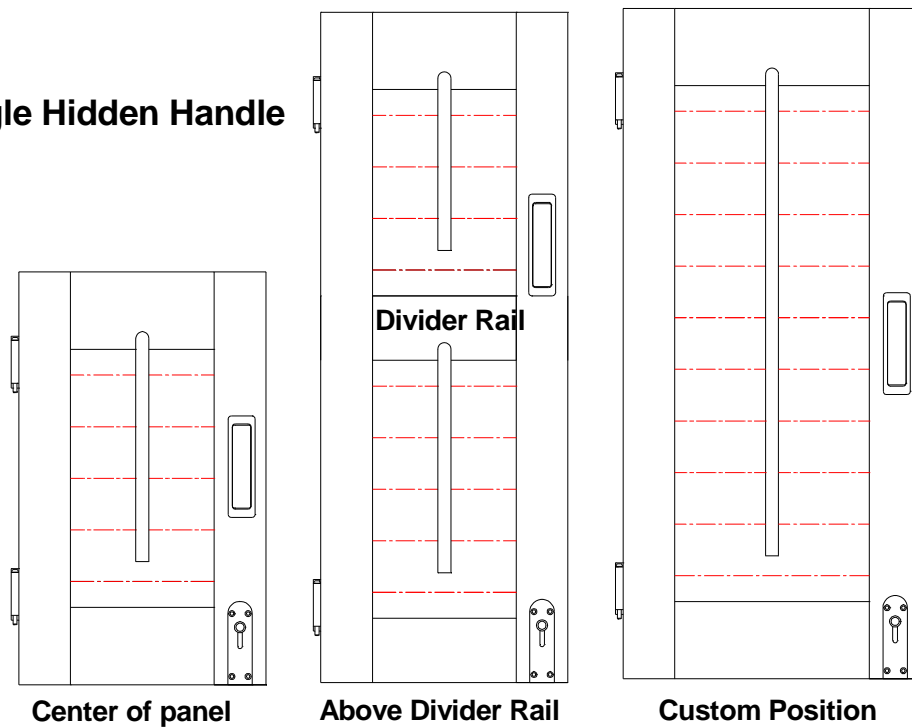

Position:

- A. Center of panel
- B. Above Divider Rail
- C. Custom Position

### Measurements:

- Window size:
  - Measure from the bottom of the window to the center of the Handles.
- Max frame-to-frame:
  - Measure from the bottom of the frame to the center of the Handles.

### Mount Options for Direct Mount:

Light block

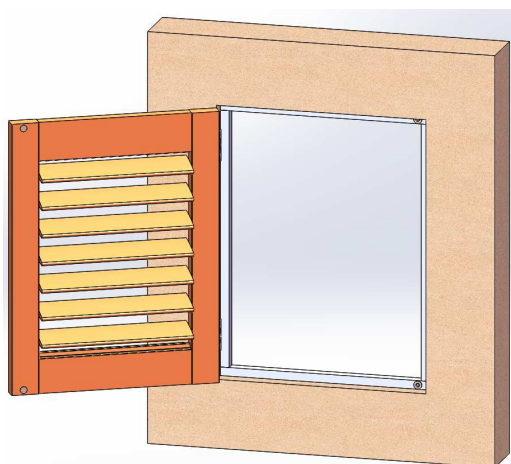

L magnet catch

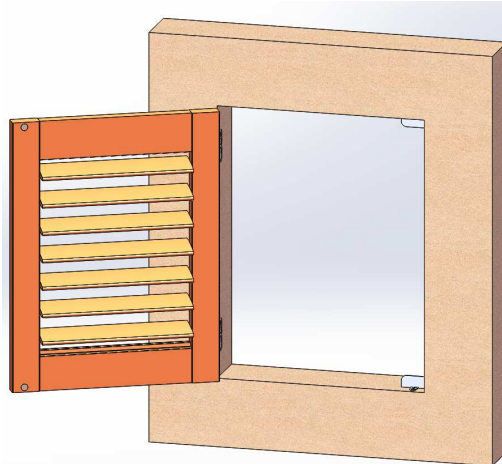

\*Some surcharges apply

- Direct mount without top and/or bottom sill option, “Light block”, “L magnet catch” and “Light block & L magnet catch” options are selectable.
- “Light block”, “L magnet catch” and “Light block & L magnet catch” options are applied to hang strip in one of the following situations:
  - 2-sided Hang strip IM without top and/or bottom sill option;
  - 2-sided Hang strip OM without top and/or bottom sill option;
  - 3-sided Hang strip OM without bottom sill option;
  - 3-sided inverted Hang strip OM beside the panel without top sill option;

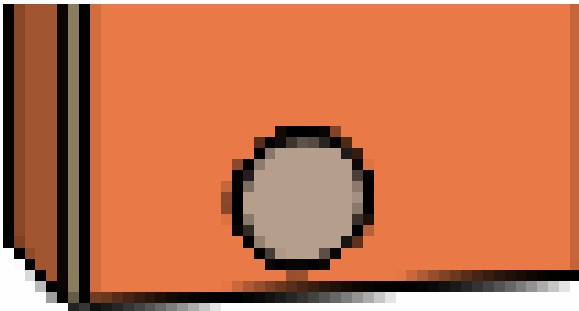

Magnet (recessed into panels)



Round Magnet Catch (installed on light blocks)

L Magnet Catch (sill magnet catch): used for catching the magnets when ordering panels without light blocks.



Round Magnet Catch and L Magnet Catch are available in:  
Pure White, Silk White, Bisque, Pearl, Bright Brass, Antique Brass, Black, Nickel plated, Crisp Linen, String, Sea Mist, Stone Gray, Brown Gray, Taupe Gray.

## Side Magnet:

Available for Butt, Rabbet and Astragal stile; Side Magnets will be applied in the following situation:

1. Double Hung shutter but without horizontal T post:

Side magnets will be applied to the meeting stiles of the L and R panel. (Default)

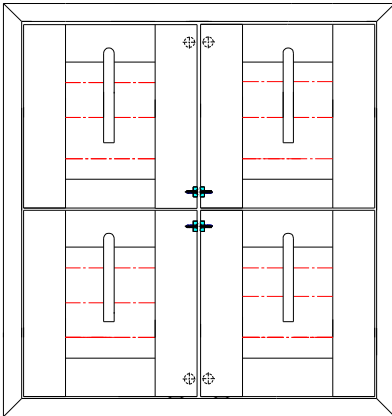

2. Café Shutter

Side magnets will be applied to the meeting stiles of the L and R panel. (Default)

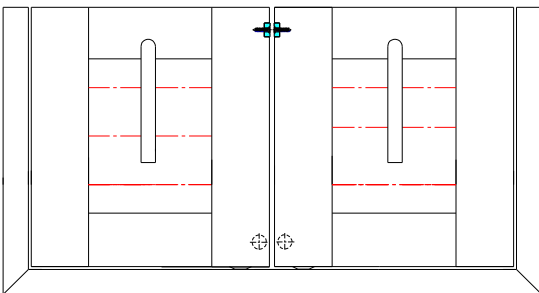

3. No frame or light block or L-shape striker plate on either top or bottom, or if larger than standard top or bottom gap is requested.

Side magnets will be applied to the meeting stiles of the L and R panel. (Optional)

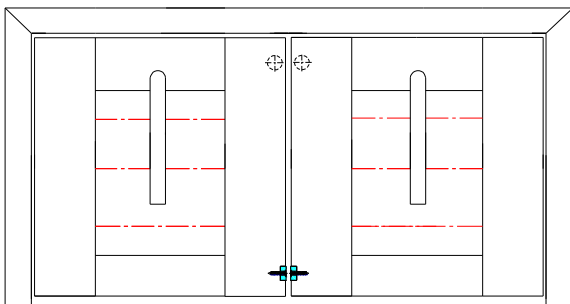

4. Note: if panels only with side magnets and there is no standard magnet on the back of panels, panels may open for external factors.

## T-Post Connector

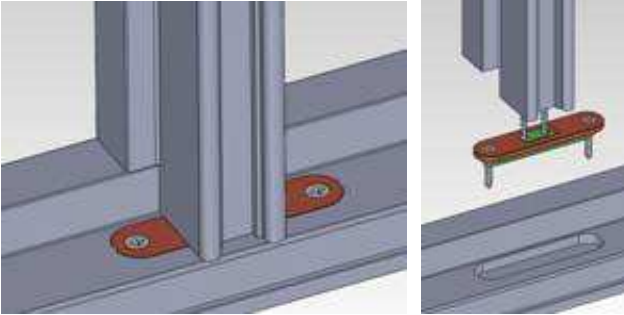

- . Available colors: Pure White; Silk White; Pearl; Bisque; Black; Nickel-Plated.
- . Available for all types of T Posts (custom-width T posts excluded).

### T Post Connector can be used with the following Frames.

#### L Frame:

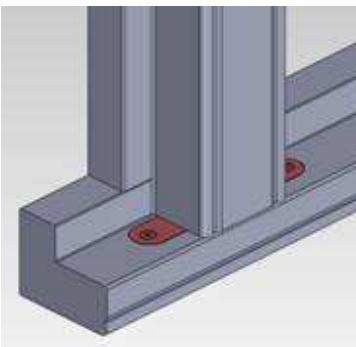

#### Deco Frame:

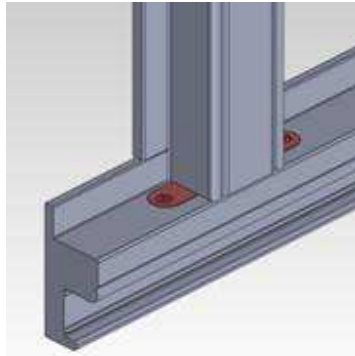

#### Z Frame:

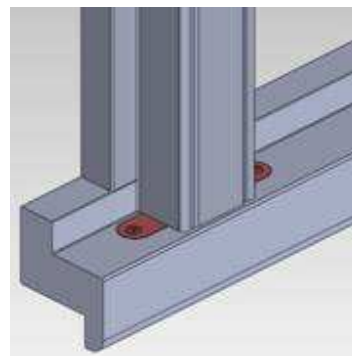

#### Hang Strip (Beside)

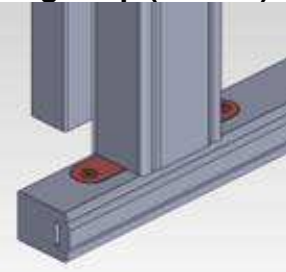

#### Note:

1. For Horizontal T Post, Hang Strip (Behind) and shutter with 1.6"/2" Sill, T Post connector is not available and T Post will be installed by screws instead;
2. If there is a panel lock which may interfere with the T-Post connector, all the T-Posts for the entire shutter will be installed with screws and the frames to be pre-drilled, even in cases where the panel lock may only interfere with one T-Post;
3. The screw color is nickel-plated regardless of the color of the T Post connector;
4. T post connectors can only be installed on a straight piece, and screws will be used instead for T Post installed on a curved or raked piece.

**L Bracket 44mm (It is used when the T Post Connector is not available.)**

Available colors: White, Silver

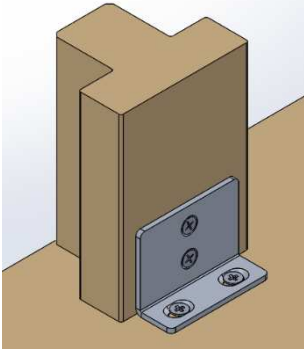

**Notes:**

1. For the Custom Paint Color orders:

- When the order only has L Bracket 44mm, but without T Post Connector, please advise the color of L bracket 44mm;
- When the order has both T Post Connector and L bracket 44mm, the color of the L bracket 44mm will match the T Post Connector color as shown in the table below:

<b>T Post Connector color</b>	<b>L Bracket 44mm color</b>
Pure White	White
Silk White	White
Pearl	Silver
Bisque	Silver
Black	Silver
Nickel-Plated	Silver

2. For the Standard Color orders, they will follow the color coordination chart as below shown:

**Paint colors (Solid colors) (24) :**

<b>No.</b>	<b>Color ID</b>	<b>Color Name</b>	<b>L Bracket 44mm color (Default)</b>
1	001	Pure White	White
2	002	Extra White	White
3	003	Silk White	White
4	004	Bright White	White
5	006	Pearl	Silver
6	007	Ivory Lace	Silver
7	009	Creamy	Silver
8	012	Crisp Linen	Silver
9	013	Bisque	Silver
10	017	Gray Black	Silver
11	019	String	Silver

12	032	Sea Mist	Silver
13	046	Ice	White
14	053	Clay	Silver
15	063	Decorator's White	White
16	066	Winchester White 2010	Silver
17	076	Aura White	White
18	080	Taupe Gray	Silver
19	836	Classic Black	Silver
20	090	TS White	White
21	600	True White	White
22	601	Chiffon	White
23	603	Natural Linen	Silver
24	609	Chateau Brown	Silver

Optional Poles:

### 1. Terminology

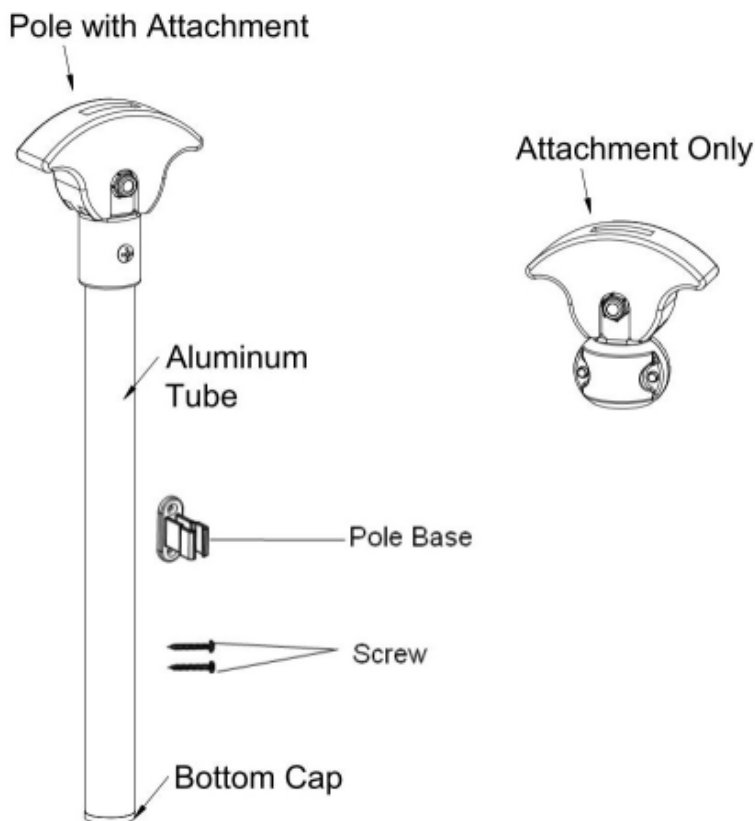

\*Some surcharges apply

**Component**

NO.	Name	Note
1	Pole with Attachment	Aluminum Tube, Pole Base and Bottom Cap included *Surcharge applies.
2	Attachment only	<ul style="list-style-type: none"> <li>● Compatible with extension poles found in most home improvement stores.</li> <li>● Screw thread (3/4") and thread pitch (1/5")</li> </ul> *Surcharge applies.

2. Available Pole Length

Two lengths available:

- 36"
- 60"



## Bi-fold 180™

### Guidelines

<u>Description</u>	<u>Minimum</u>	<u>Maximum</u>
Single-Panel Width (Bi-fold Track)	6"	26"
Single-Panel Width (LLL/RRR)	6"	20"
Single-Panel Height	10"	132"

### Outside Mount

Max frame-to-frame width: window width + 3 1/2"

Max frame-to-frame height: window height + 4 1/2"

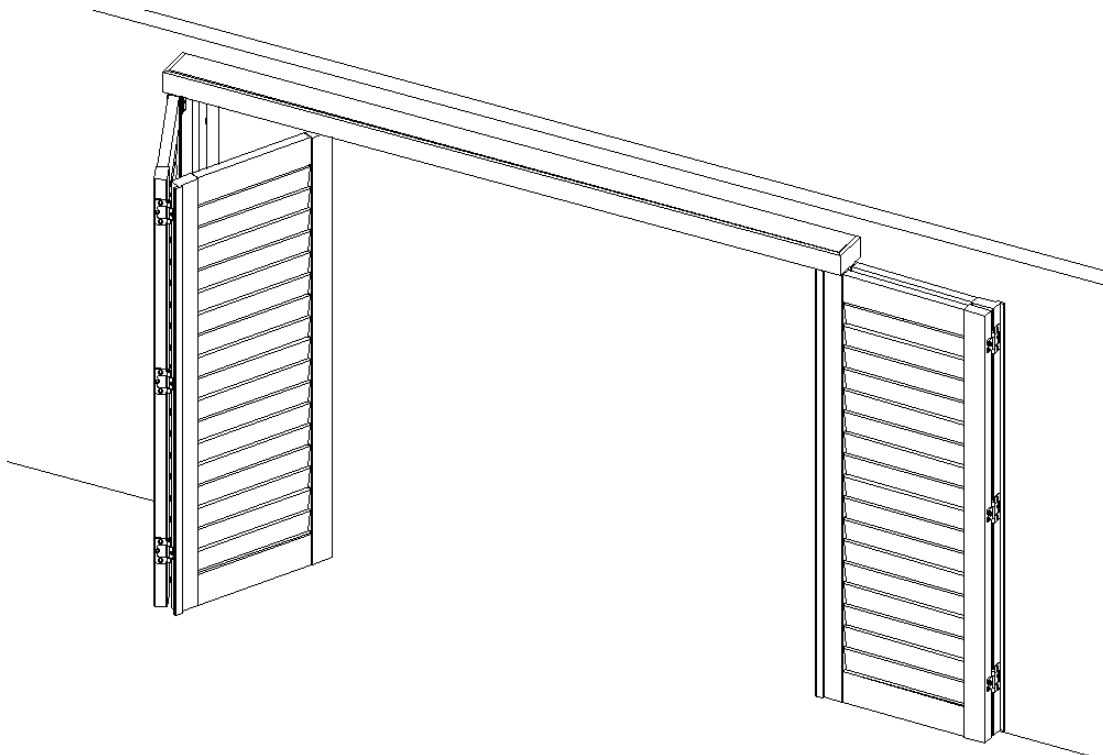

- Track is pre-installed on the header; standard 1 track only.

Mounting Options: Outside Mount only

Side View

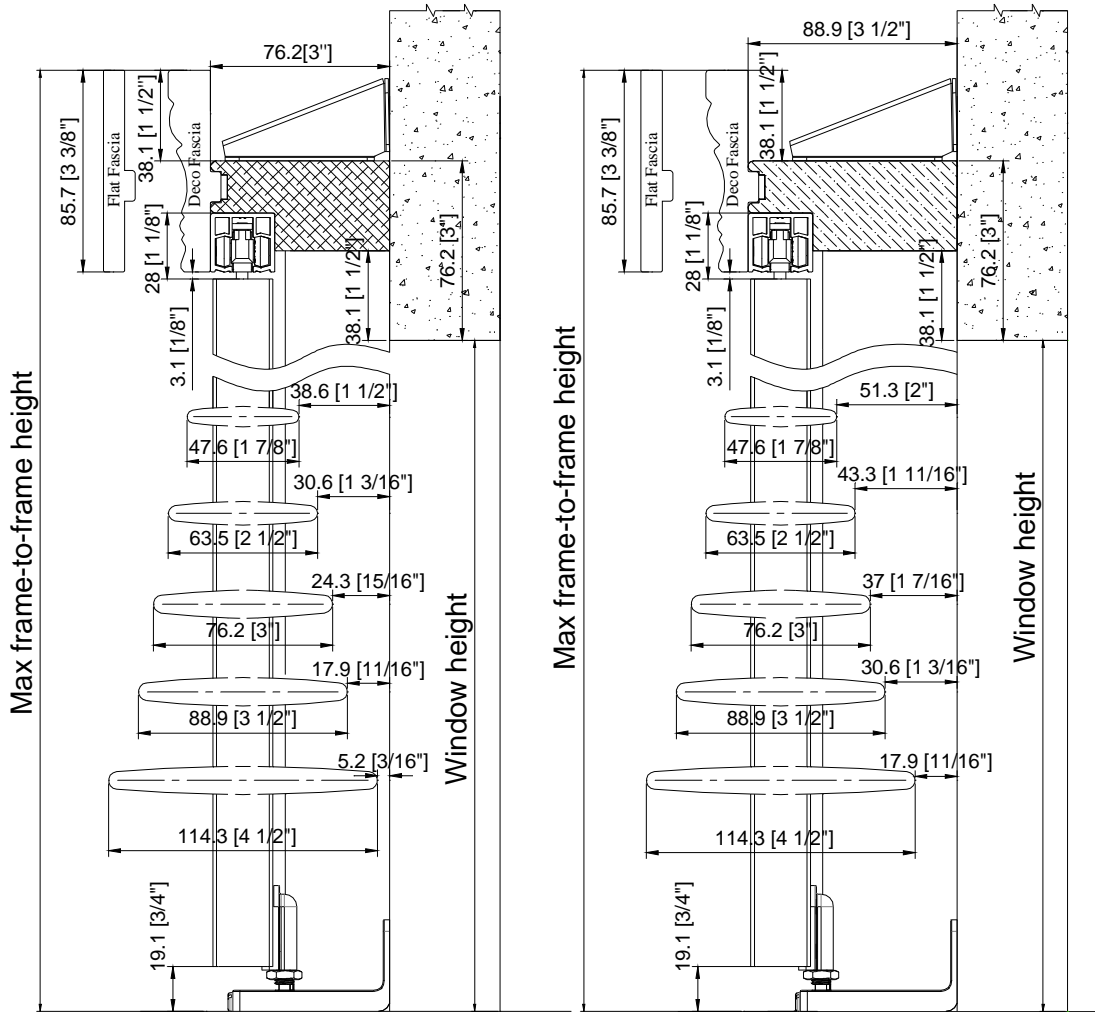

Top View

Without Casing:

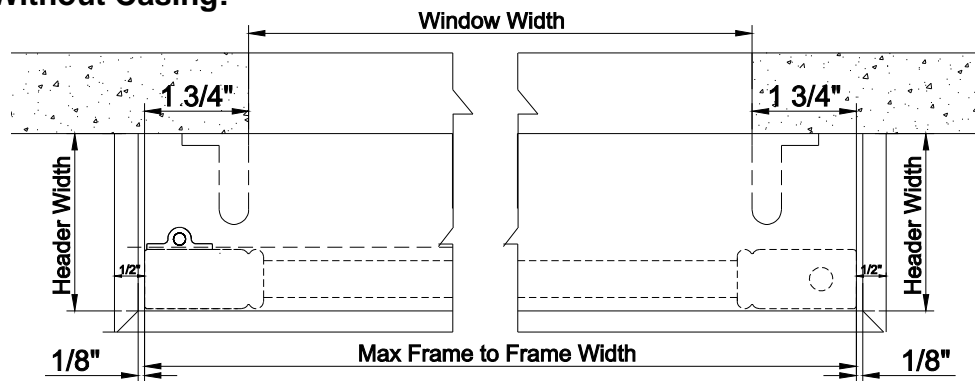

Note:

- ◇ Fascia return will protrude the panel about 1/2" for each side.
- ◇ The header will protrude the panel about 1/8" for each side.
- ◇ Header, light blocks, and bottom pivot bracket(s) must be installed on a flat surface.

**With Existing Casing:**

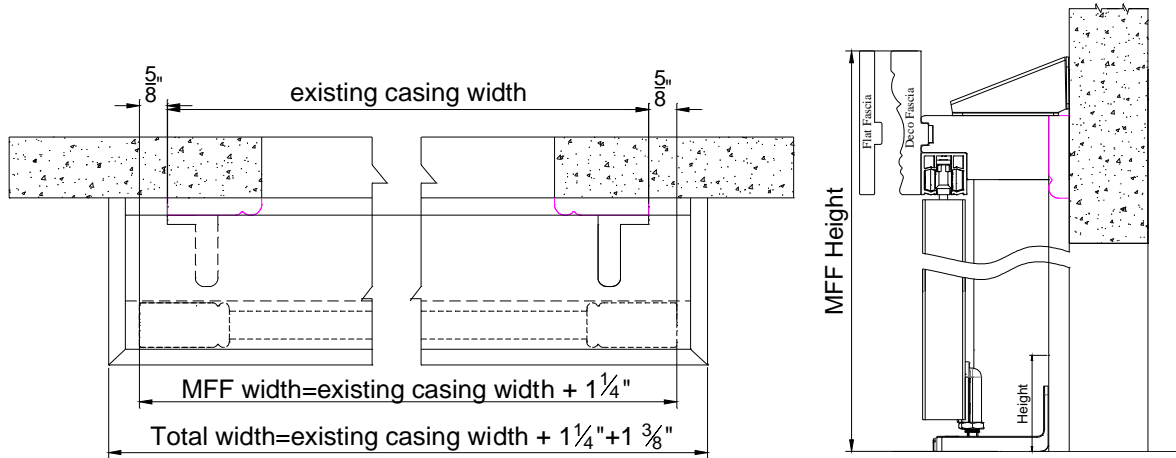

- ✧ Header Extension: Optional
- ✧ Custom extension up to 2" for Header
- ✧ When extension is needed, the header will protrude the panel 5/16" for each side and the fascia return will protrude the panel 11/16" for each side.

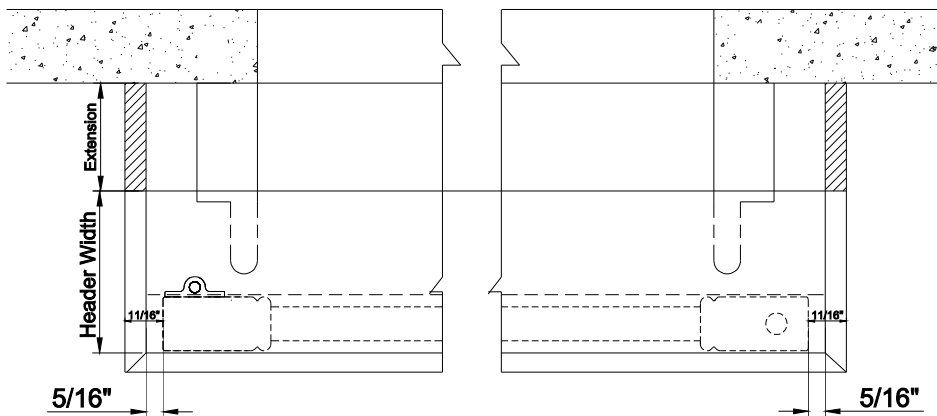

The extension will be pre-attached.

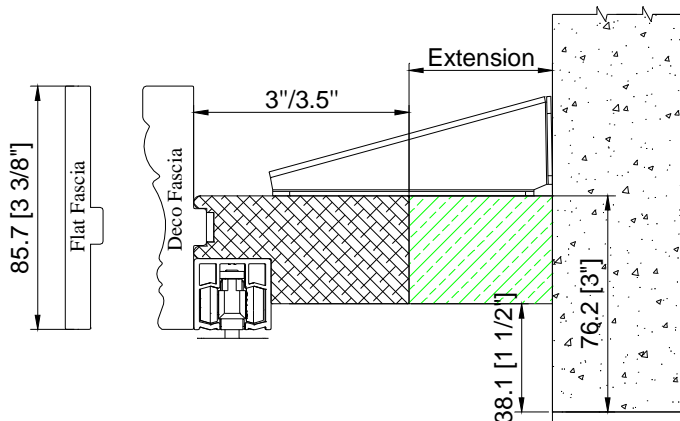

For 180 Bi-fold, if Bottom Pivot L Bracket is required, the extension for the L shape light block will be 1 3/4" in width. Please see picture below:

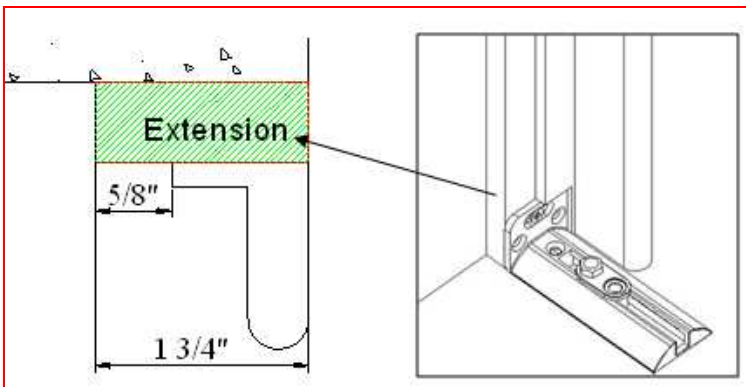

**Panel Configuration : Only 2", 2 1/4" rabbet and butt stiles are available. Center stile is not available.**

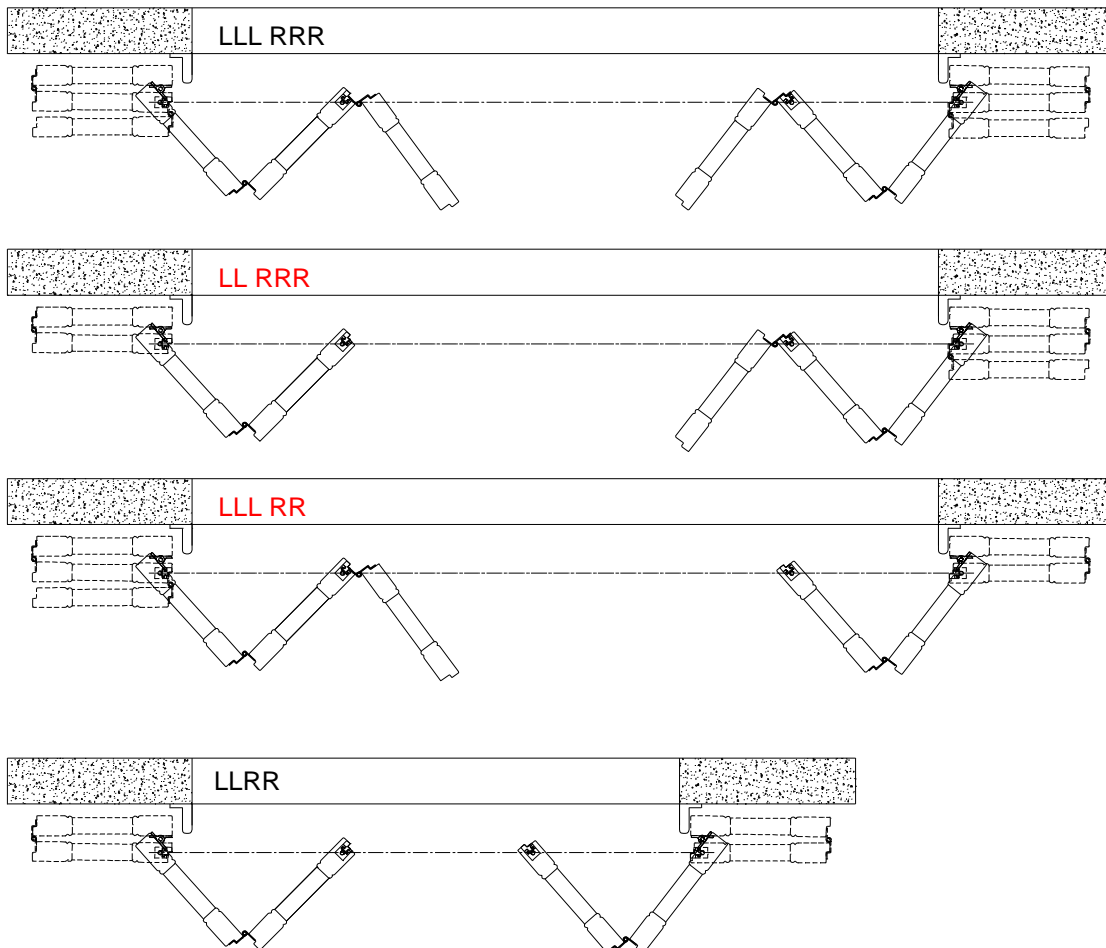

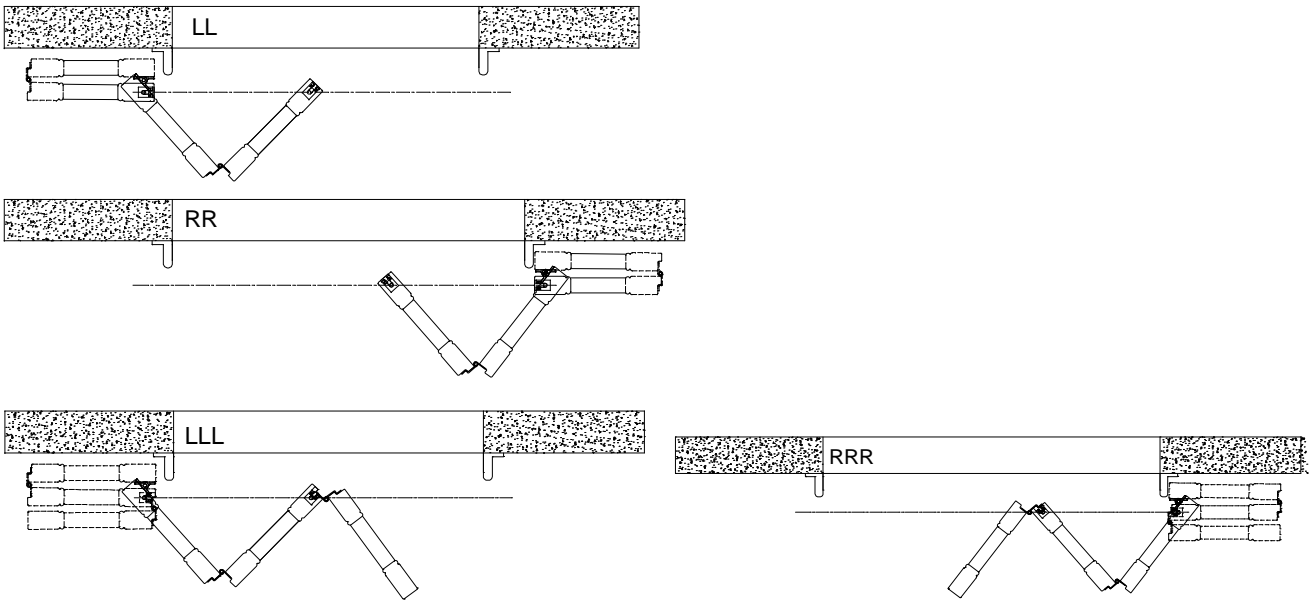

**Notes:**

If there is no baseboard to the wall, 3" header can be used.

If there is baseboard to the wall, then it should be as below:

1. If base board thickness is less or equal to 5/8", 3 1/2" header can be used.
2. If base board thickness is over 5/8", it is suggest using the 3" header with build out. And the build out thickness=base board thickness-1/8".

Please see the drawing below:

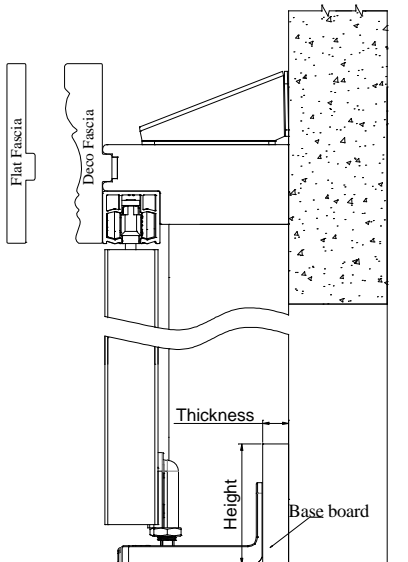

**180° Bi-fold Track Shutters Framing Materials**

Type	Header Dimension	Top Fascia Dimension	L Shape Light Block Strip Dimension
Header & Top Fascia & Light Block Strip	3"	3 3/8"	1 9/16"
	3 1/2"		2 1/16"

## 180° Bi-fold Track Shutters Hardware Box

<b>Parts</b>
Wrench
Hinge Pin
Triangle Bracket (based on the length of header)
2" screws for Triangle Bracket
¾ " screws for Triangle Bracket
Bottom Pivot Bracket
1 ½ " screws for bottom pivot bracket
2 ½ " screws for Frame with predrilled screw holes

## Bi-fold 90<sup>™</sup>

Guidelines and Specs:

<u>Description</u>	<u>Minimum</u>	<u>Maximum</u>
Single-Panel Width (Bi-fold Track)	6"	26"
Single-Panel Width (Multifold track up to 4 panels)	6"	20"
Single-Panel Height	10"	132"

### Outside Mount

Max frame-to-frame width: window width + 3 1/2"

Max frame-to-frame height: window height + 4 1/2"

### Semi-Inside Mount

Max frame-to-frame width: window width - 1/8"

Max frame-to-frame height: window height + 1 3/8"

### Inside Mount

Max frame-to-frame width: window width - 1/8"

Max frame-to-frame height: window height - 1/8"

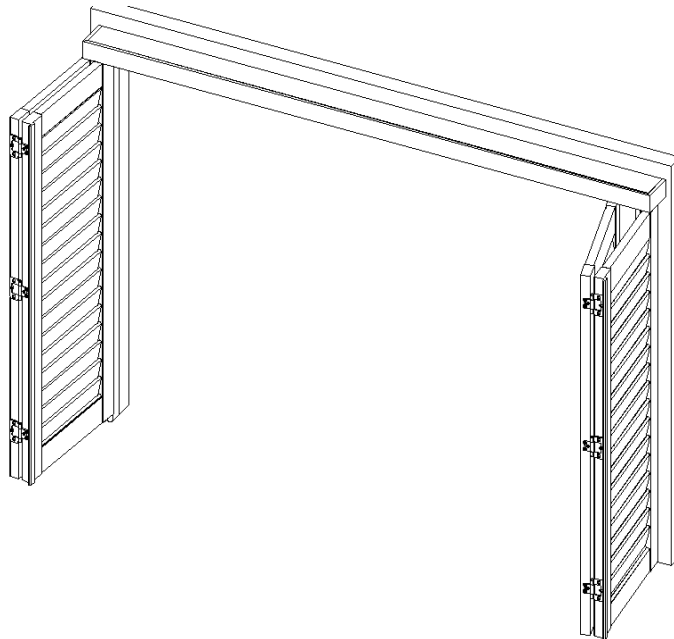

Track is pre-installed on the header; standard 1 track only.

Mounting Options: Outside Mount

Side View

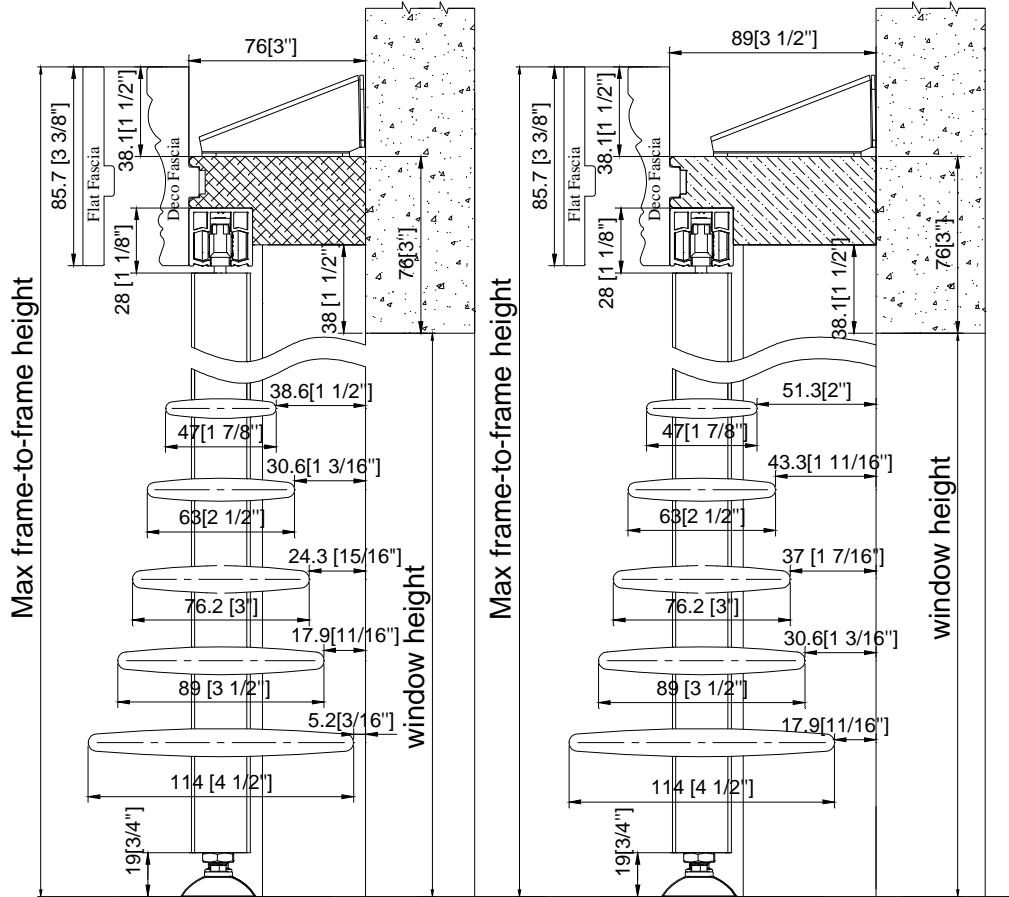

Top View

Without Casing:

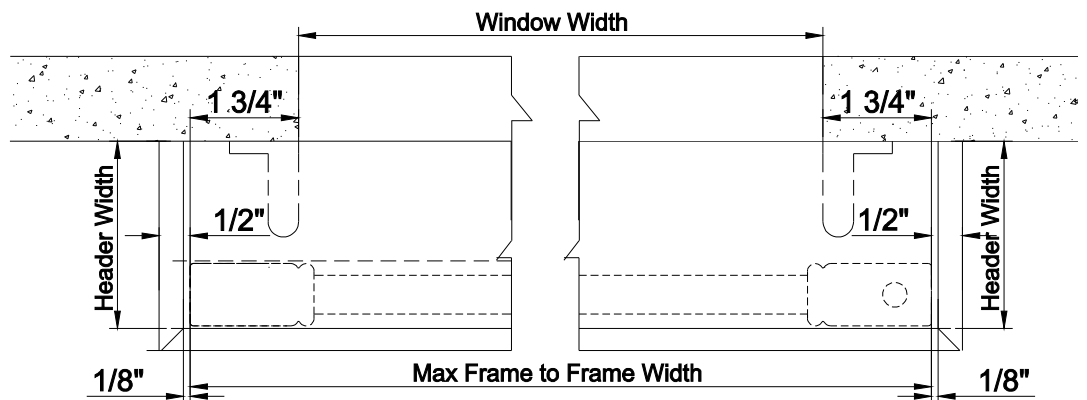

Note:

- ◇ Fascia return will protrude the panel about 1/2" for each side.
- ◇ The header will protrude the panel about 1/8" for each side.
- ◇ Header, light blocks, and bottom pivot bracket(s) must be installed on a flat surface.



With Existing Casing:

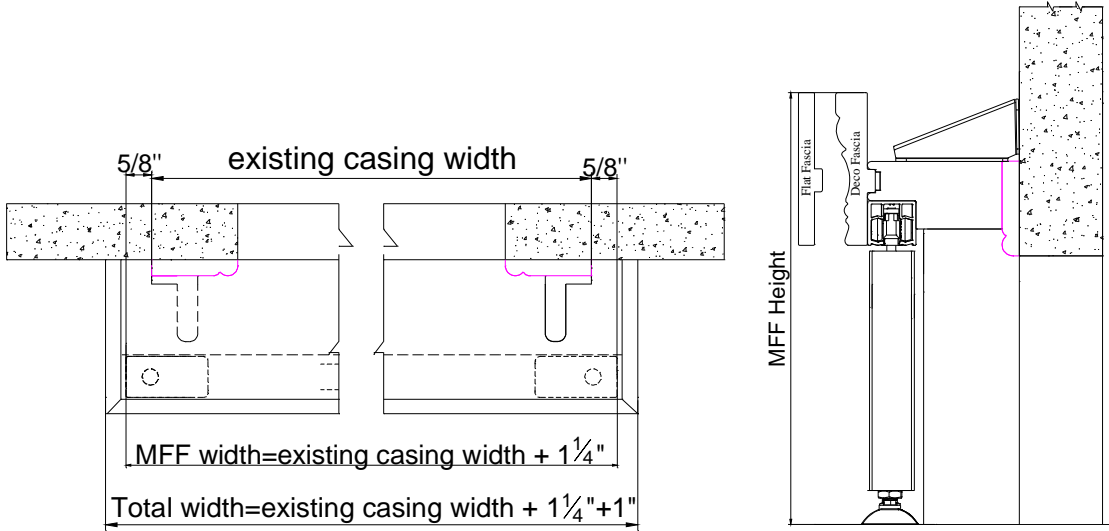

Semi-Inside/Inside Mount

Side View

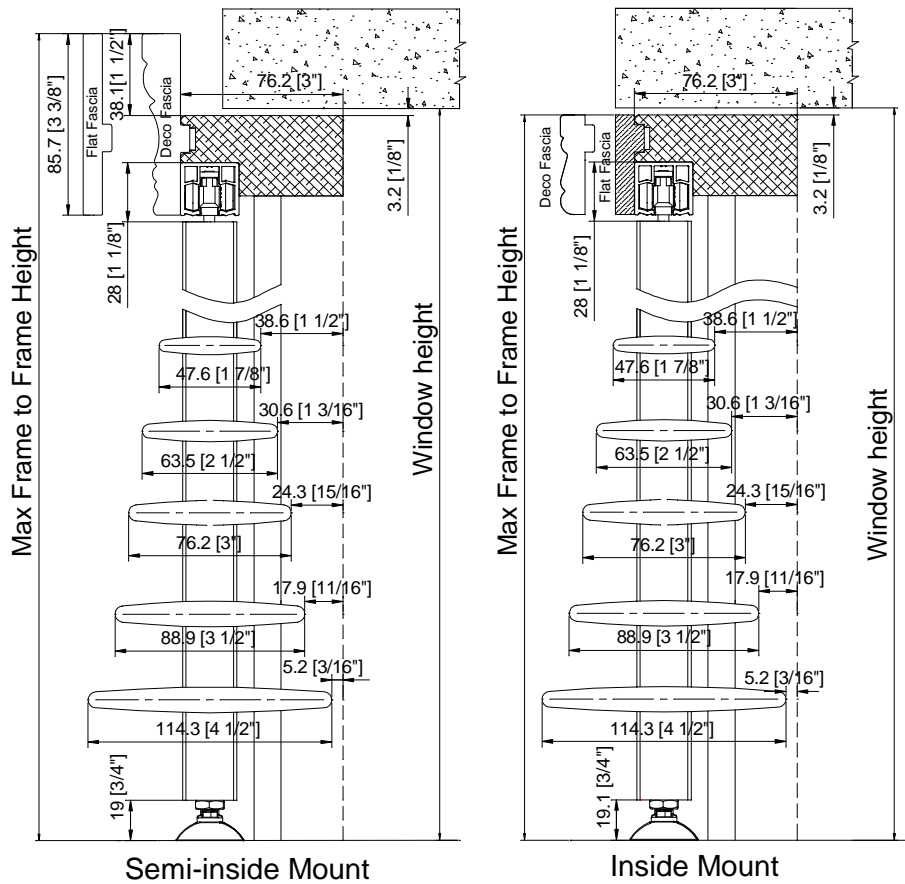

### Semi-Inside Mount Top View

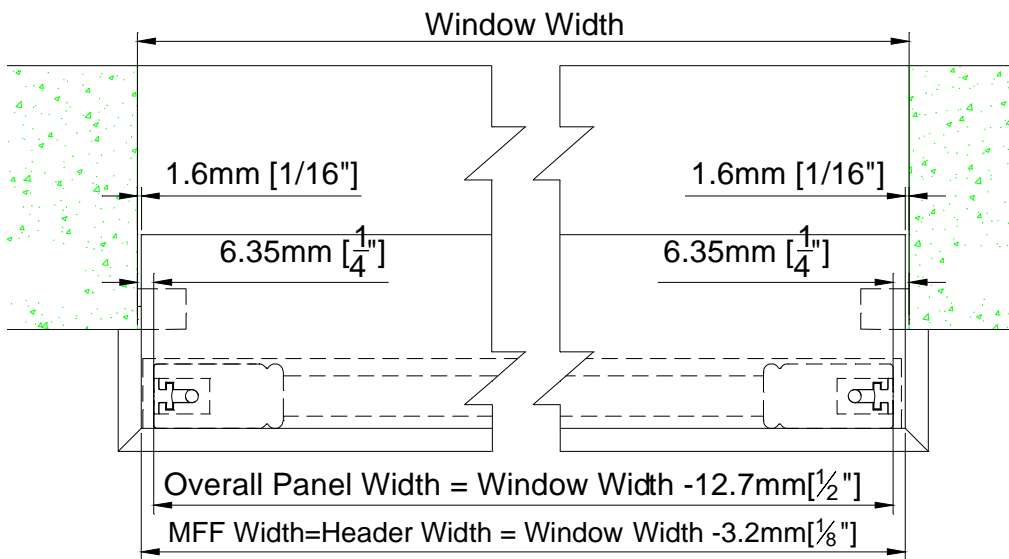

### Inside Mount Top View

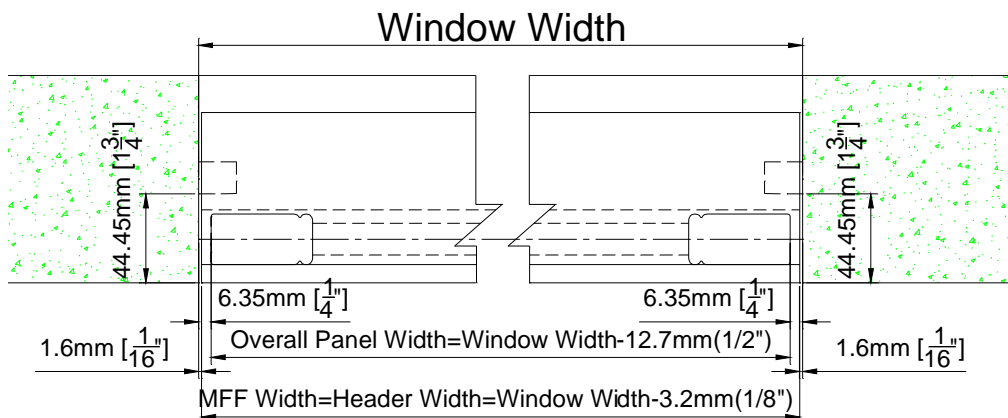

- ✧ Header Extension: Optional.
- ✧ Custom extension up to 2" for Header
- ✧ The extension will be pre-attached.

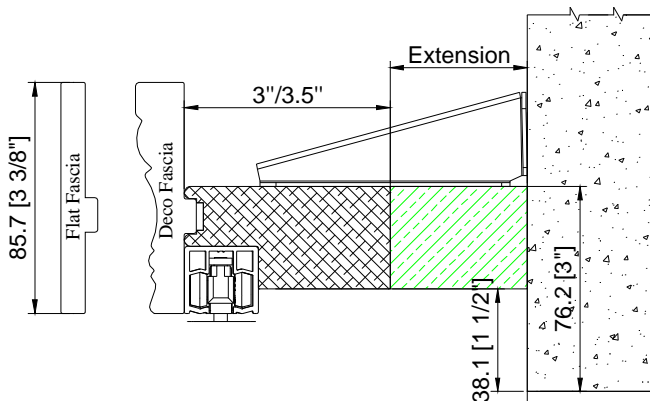

**Panel Configuration : Only 2", 2 1/4" rabbet and butt stiles are available. Center stile is not available.**

LL or RR

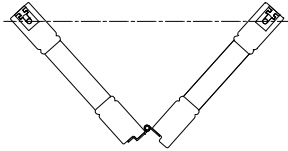

LLRR

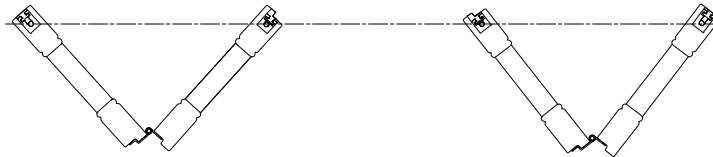

### 90° Multi-Fold Track Shutters (Wood only)

Maximum single panel width for multi-fold is 20"

Panel Configuration: LLLL, RRRR, or LLLLRRRR

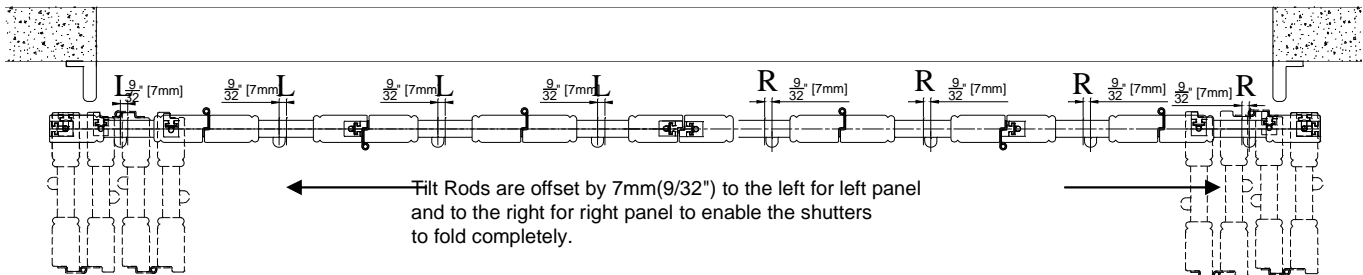

### 90° Floating Panels

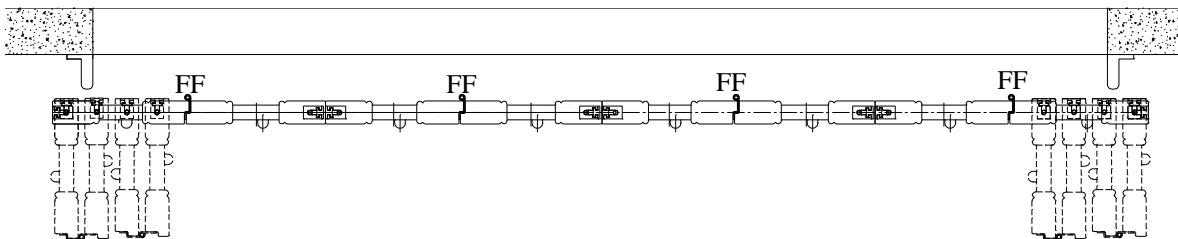

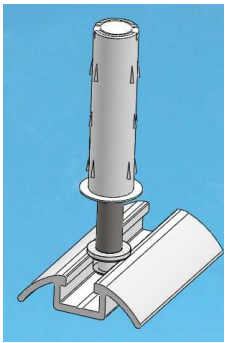

- Two or four panels can be hinged together, fold and slide to either direction
- Application comes with wheel carrier, spring loaded guide and floor track
- Can be used on large window

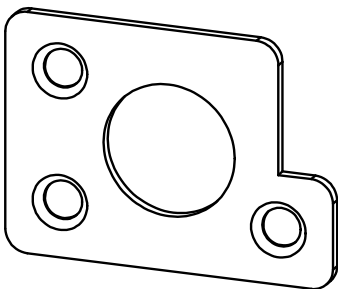

Spring loaded guide plate  
(for wood panel with spring loaded guide in all Bifold track systems)

Note: For 90° Floating Panels outside mount/semi-inside mount without side boards, the 2016 Stopper will be supplied by default. The gap between the fascia return / end of top track and the panel is 5mm each side.

The 2016 stopper can also be used in the center or any position of the top track as an option.

### 2016 Stopper

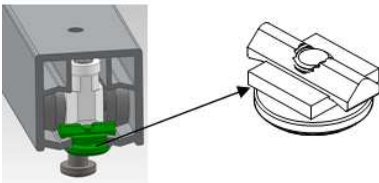

Please see drawing below to show the gap.

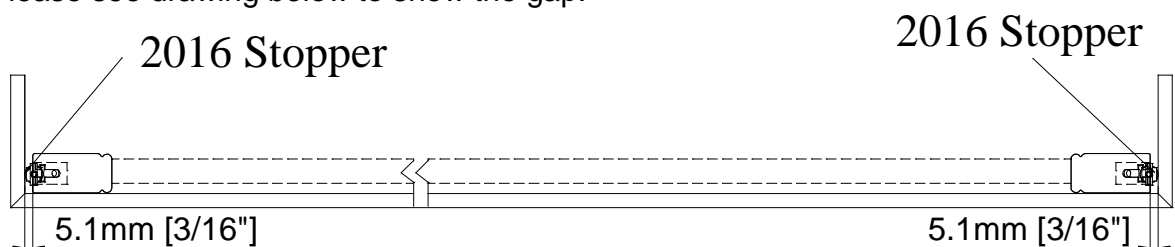

2. When rabbet stile required, the meeting stile of unhinged stile will be butt stile by default.

90 Degree Bi Fold Track Shutters Framing Materials

Type		Header Dimension	Top Fascia Dimension	Light Block Strip Dimension
Header & Top Fascia & Light Block Strip	OM	3"	3 3/8"	1 9/16"
		3 1/2"		2 1/16"
	Semi-IM	3"	5/8"x3/4"	
	IM	3"	1 7/8"	5/8"x3/4"

Note: It will be L shape light block strip for outside mount.

# Frame Hinged Bifold

Available Stile: Rabbet Stile Only

Available Frame type

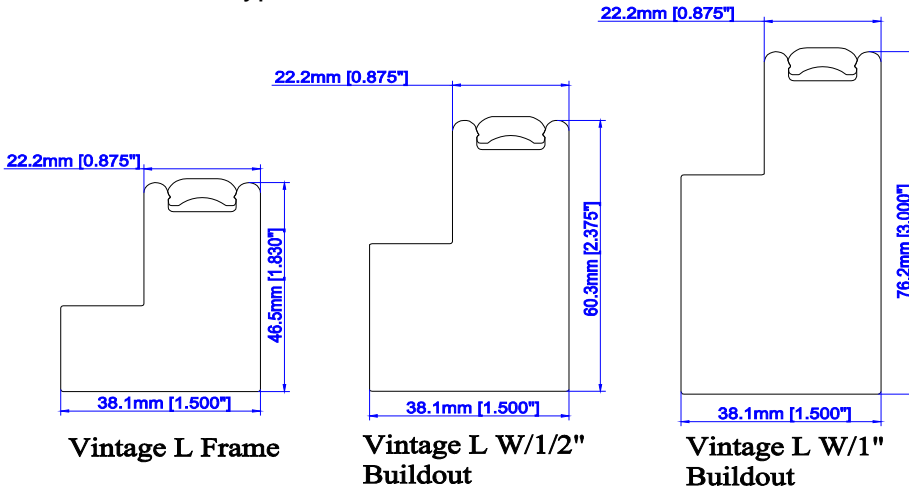

**Vintage Hang Strip with 13mm light block:** For single direction shutter with even panel qty, the frame on the unhinged side will be Vintage Hang Strip with 13mm [0.512"] light block, the height of the Vintage Hang Strip will match with that of the hinged side frame. The Vintage Hang Strip will be made in wood with surcharge.

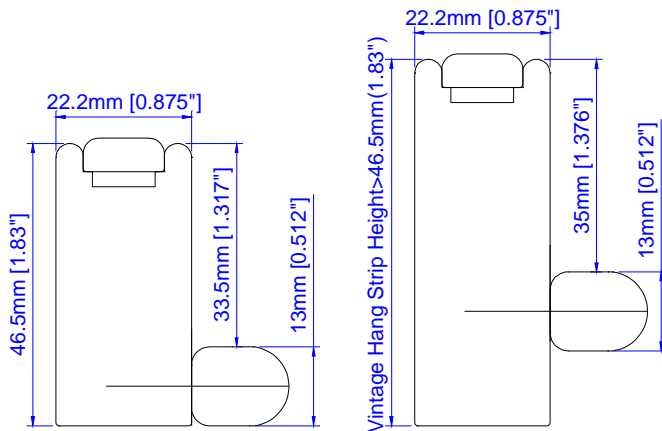

## Top View

Hinged at Left or Right with wheel assembly at top;

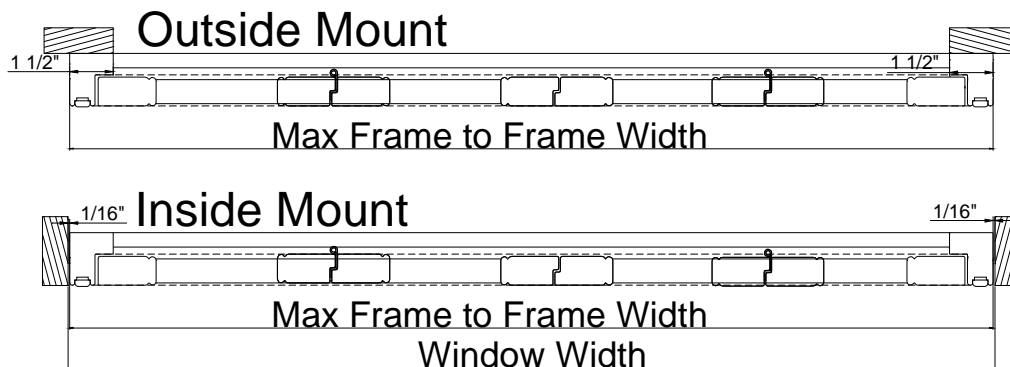

**Side View**  
Outside Mount  
3-Sides + bottom light block

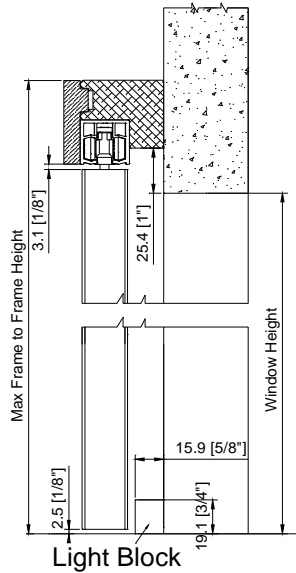

3-Sides + 3" Deco Sill Frame

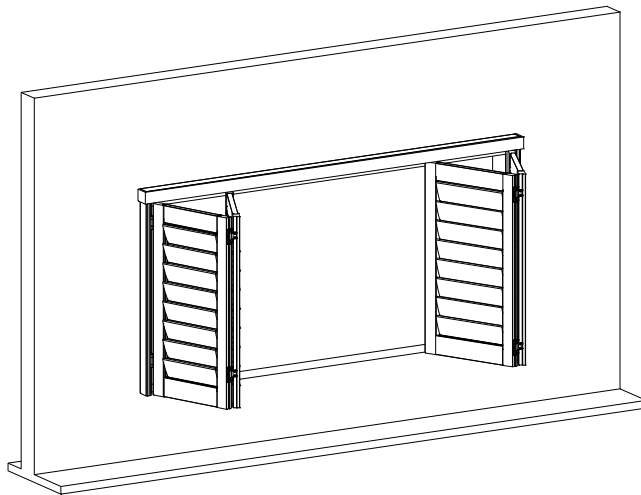
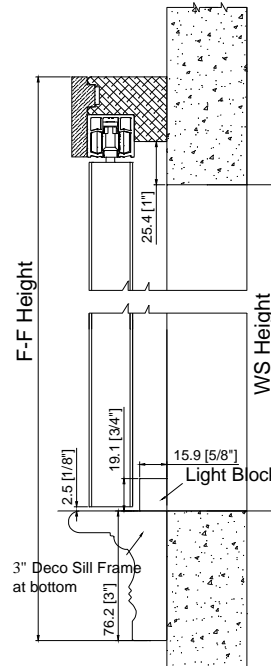

Note: For OM Frame Hinged Bifold shutter not to use as a door, if there is no existing sill at the bottom of the window opening, it is recommended to have the 3" Deco Sill Frame at the bottom.

Semi-Inside

Inside Mount

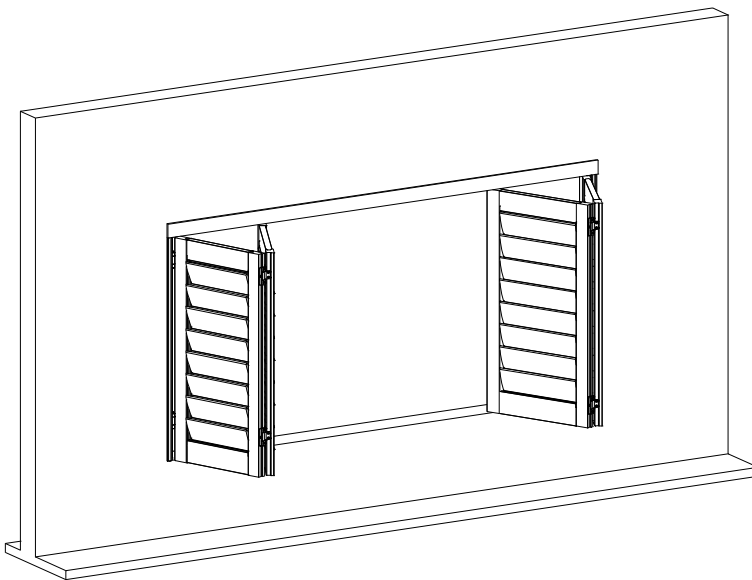
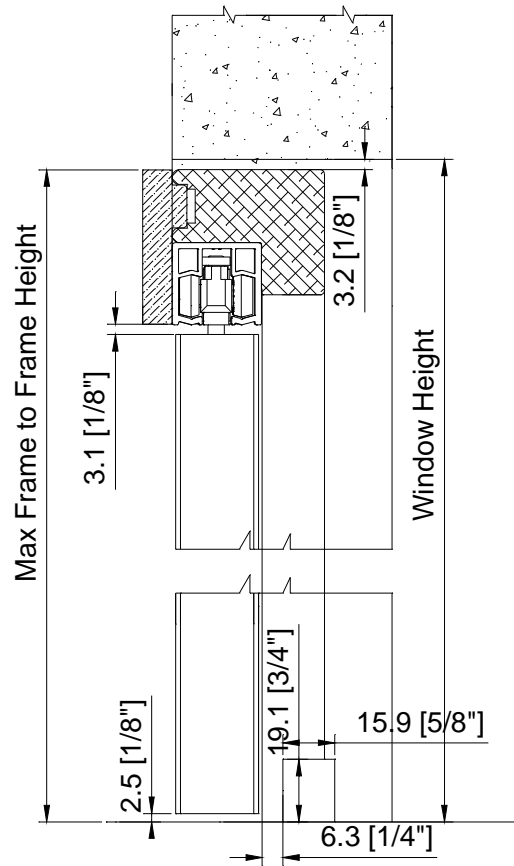
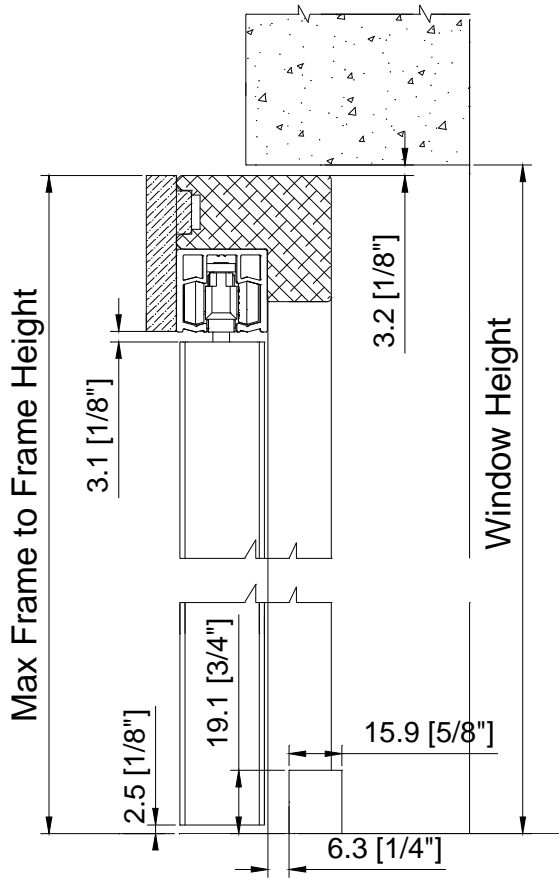



For frame hinged bifold track shutter used as door, the bottom gap will be 19mm by default. Please specify "Used As Door" on the order form.

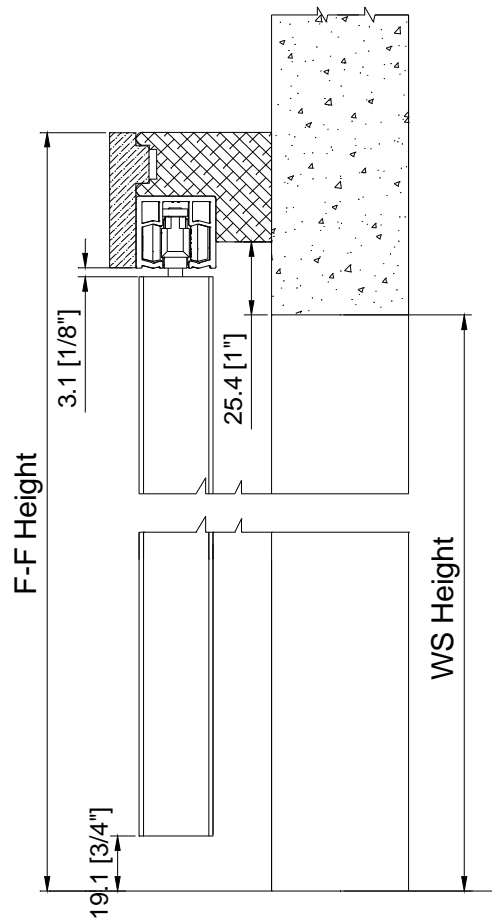

Panel Configuration (uneven panel width)

- 1) If the hinge type between panel and frame is 2 3/8" Self Mortise Hinge, the panel width1 (hinged with Self Mortise Hinge) = A, the other panels width (panel width2 / panel width3 / panel width4) = A + 34.5mm;
- 2) If the hinge type between panel and frame is Invisible Hinge, the panel width1 (hinged with Invisible Hinge) = A, the other panels width (panel width2 / panel width3 / panel width4) = A + 29.5mm;

Take the drawings of the hinge type between panel and frame is 2 3/8" Self Mortise Hinge as examples:

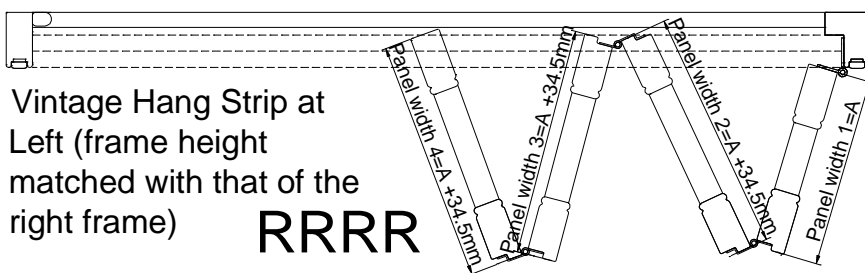
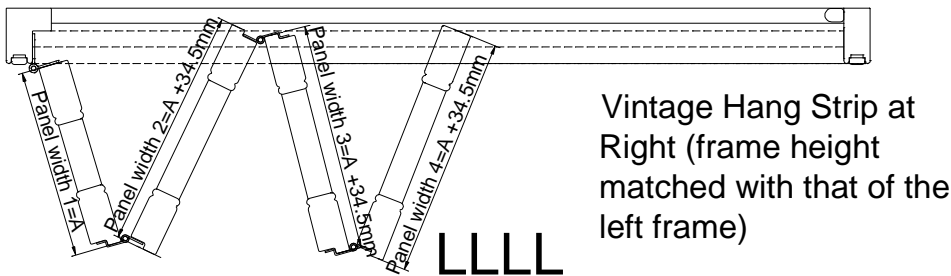
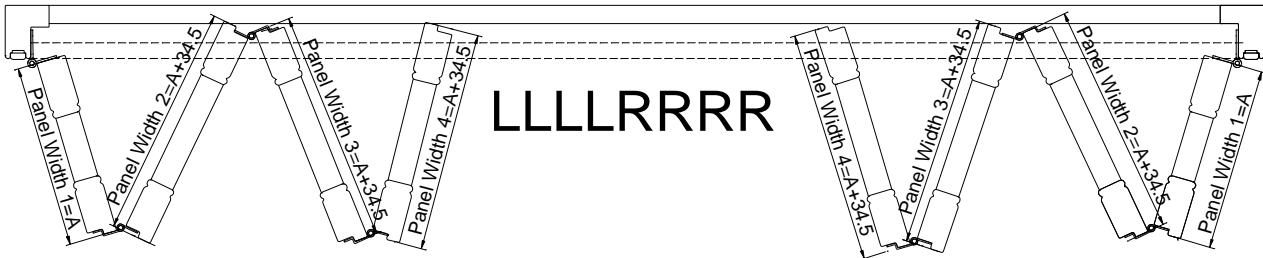
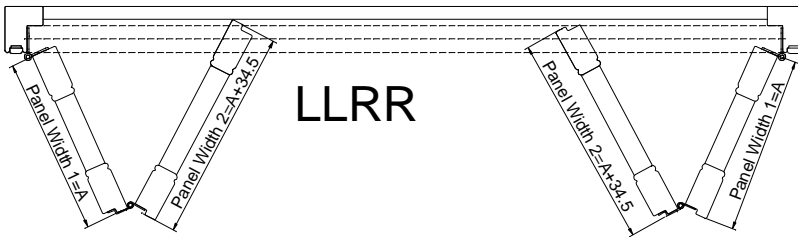
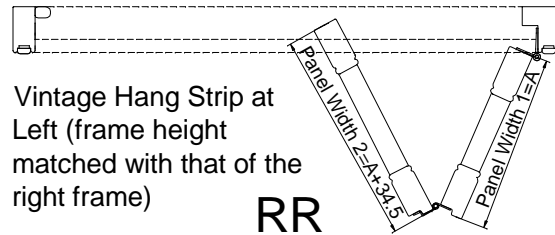
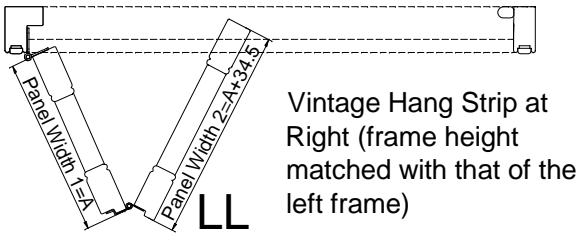

Notes:

1. Only available for 3-Sides + bottom light block or 3-Sides + 3" Deco Sill Frame (4-sides is not available); Panels can be folded and open at 90 degree;

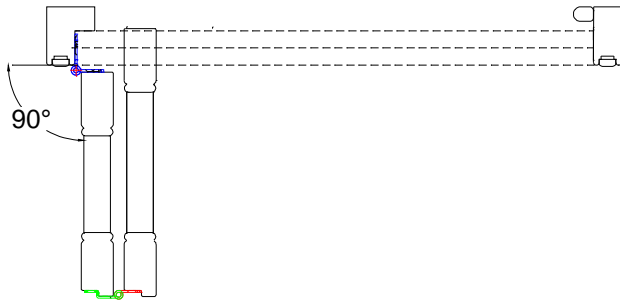

2. Frames available: Only Vintage L Frame

- 1) For top frame, the insert will be replaced by top fascia;
- 2) Top track will be pre-attached to the top frame;
- 3) Frame will be pre-drilled with screw holes same as regular shutters.

**Ring Pull:** The ring pull will be provided as an option; Customer need specify ring pull location on the order form. Ring pull location is measured from the floor to center of the ring pull in height direction.

Ring pull color will match the hinge color.

Please refer to below drawing of ring pull position for all shutter type:

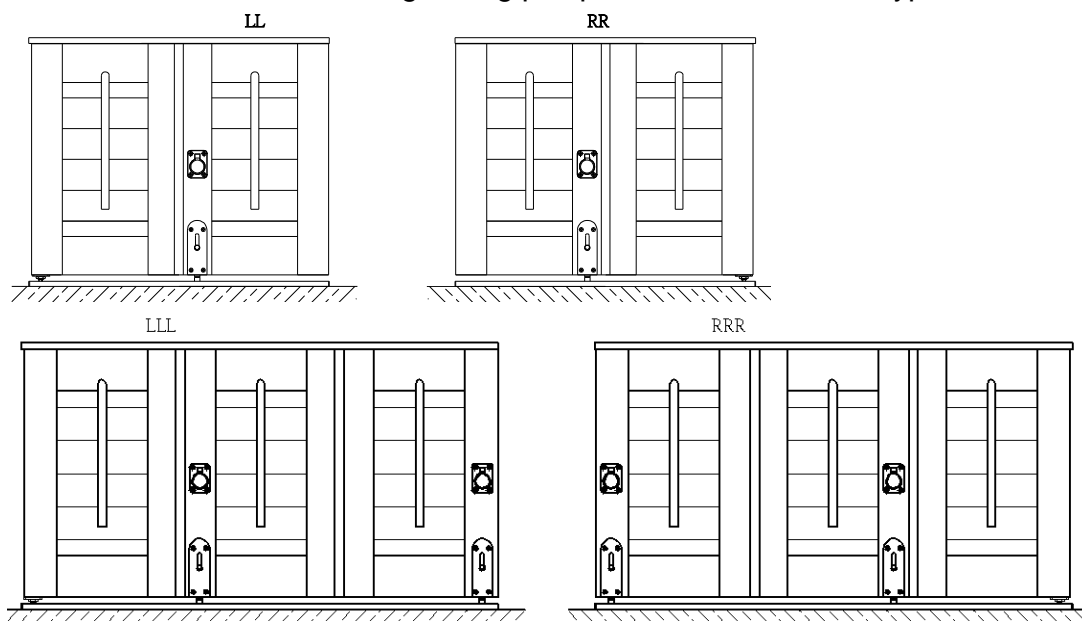



**Bottom Pivot Brackets:**

For 90° Bifold Track Shutter, there will be 2 types of Bottom Pivot Brackets available.

**Bottom Pivot L Bracket:**

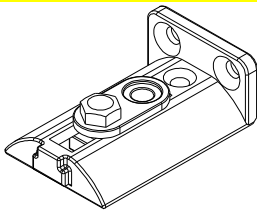

For Inside Mount, it will be supplied as default;

**Bottom Pivot Bracket:**

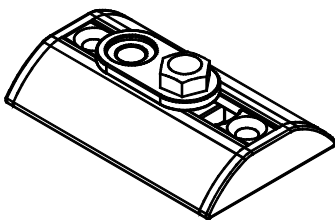

For Semi-Inside or Outside Mount, it will be supplied as default.

**81mm Bottom Pivot L Bracket:**

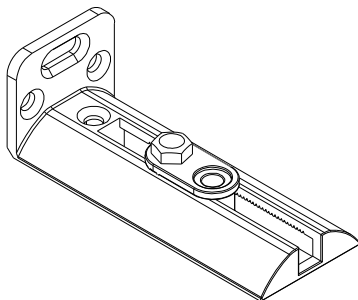

For 90° Bifold Track Shutter Outside Mount, it will be supplied as an optional. (Notes: If screwing the bracket into the floor is not an option)

For 180° Bifold Track Shutter, it will be supplied as default.

Track Dimension:

Top Track

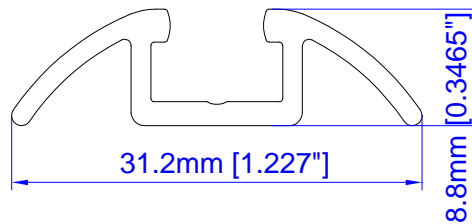
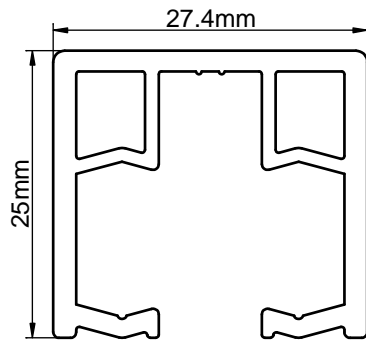

M Shape Bottom Track

Extra 8.5x25mm Magnet Catches and magnets will be supplied for Bifold hinge: (only for the most top and bottom hinges)

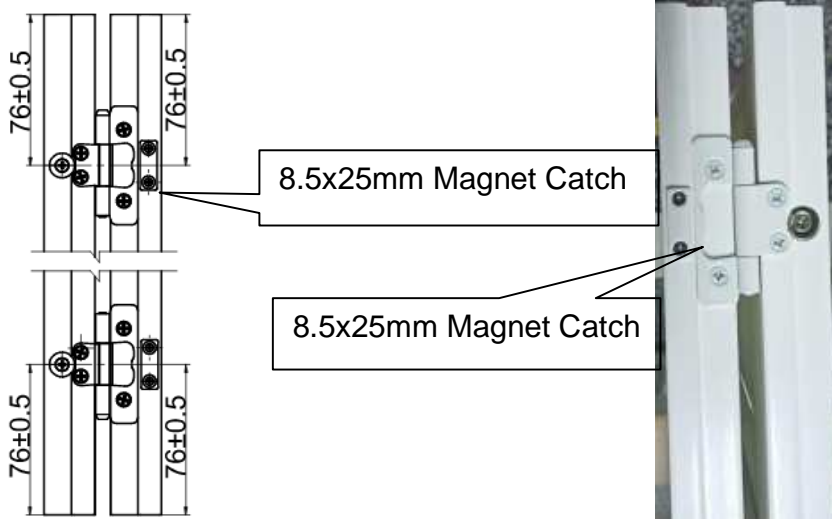

Side Magnet: applied to the meeting stiles of LR panels

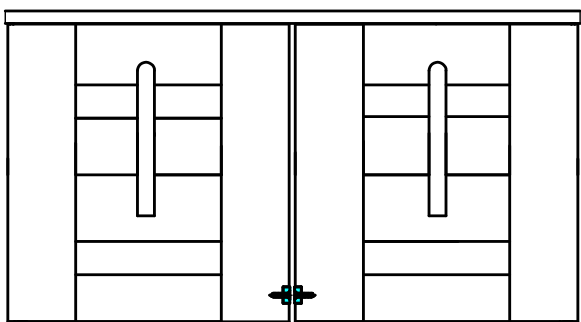

## 90° Bi Fold Track Shutters Hardware Box

Parts
Wrench
Hinge Pin
Triangle Bracket (based on the length of header)
2 " screws for Triangle bracket
¾ " screws for Triangle bracket
Bottom Pivot Bracket
38.1mm screws for bottom pivot bracket
63.5mm screws for Frame with Predrilled holes

### Notes:

1. for all bifold track shutter Outside Mount, the header will be pre-drilled with screw holes in the insert and screws will be supplied by default;
2. for all bifold track shutter Inside/Semi-Inside Mount, the header will be pre-drilled with holes for screws and wood plug, screws and wood plug will be supplied by default

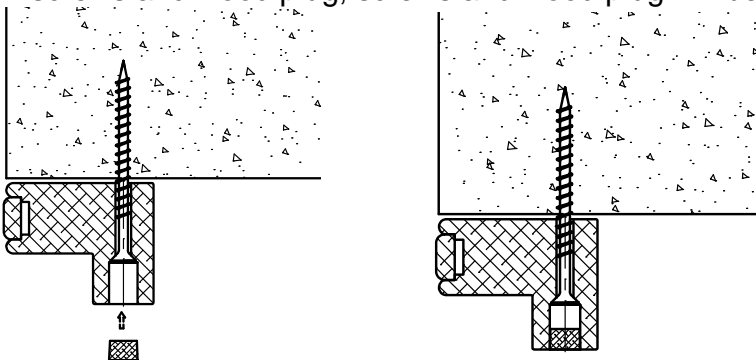

### 90 Degree Bifold Track & Floating Panels Hanger Location:

**LL/RR/LLRR**

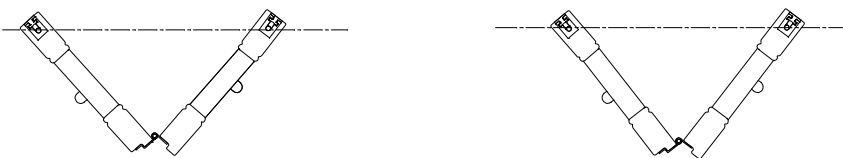

**LLLL/RRRR/LLLLRRRR**



180 Degree Bifold Track Panel Hanger Location:

LL/RR/LLRR

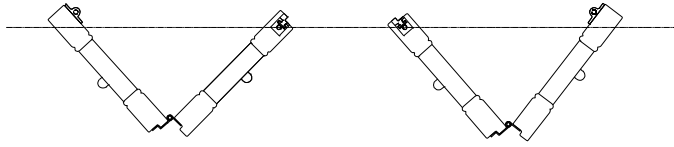

LLL/RRR/LLLRRR

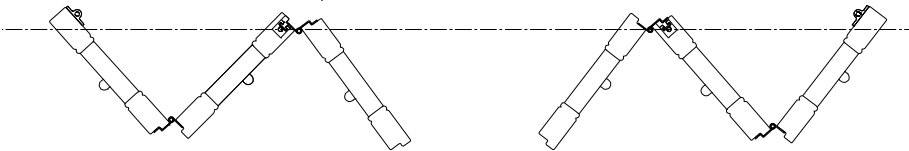

Frame Hinged Bifold Track Panel Hanger Location:

Take the drawings of the hinge type between panel and frame is 2 3/8" Self Mortise Hinge as examples:

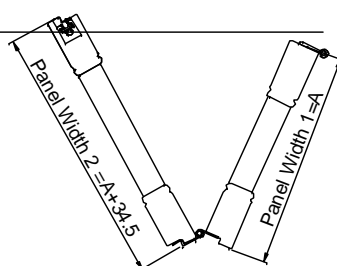
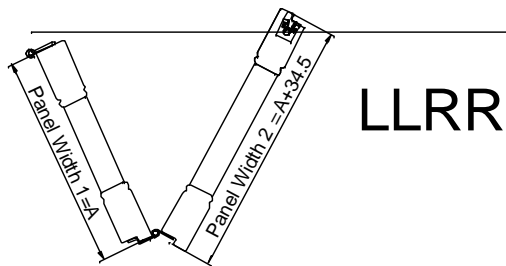
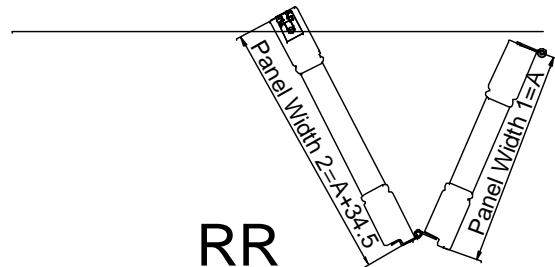
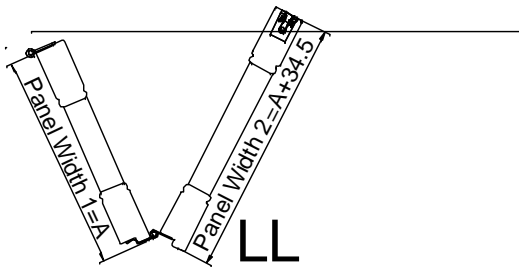

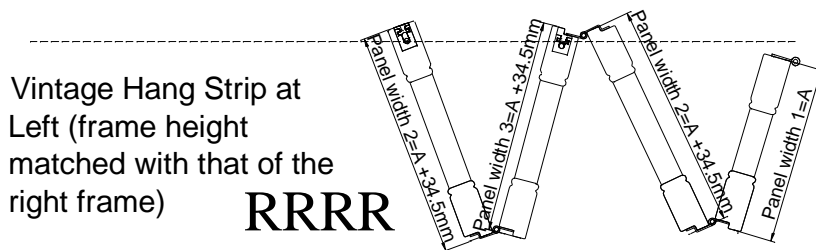
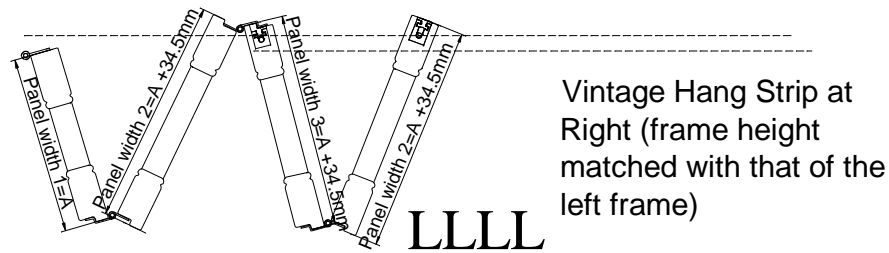
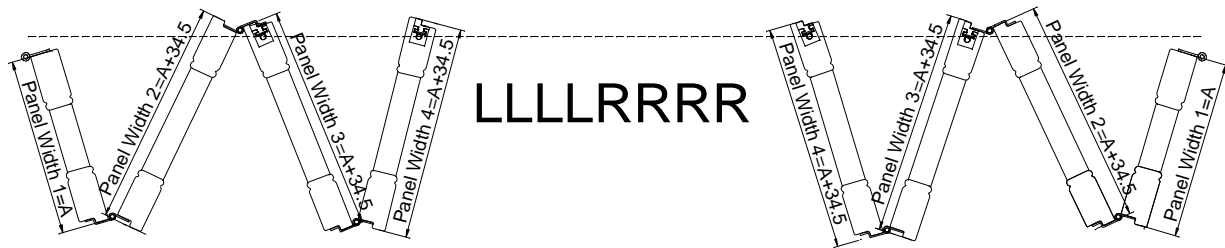

## Keystone for Fascia of the Track Shutter

When fascia length exceeds the limitation and needs to split, keystone design fascia will be supplied without surcharge for track shutters.

For fascia length within the split limitation, keystone can also be supplied as an option with surcharge.

For Deco Fascia:

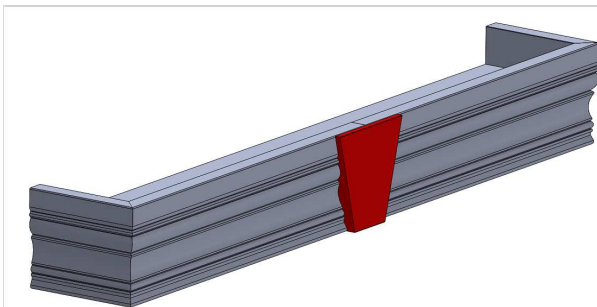

For Flat Fascia:

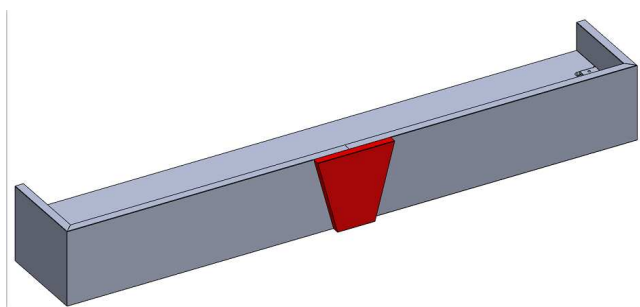



The keystone will be installed by screws. We will pre-drill the screw holes and the screws will be packed in hardware box.

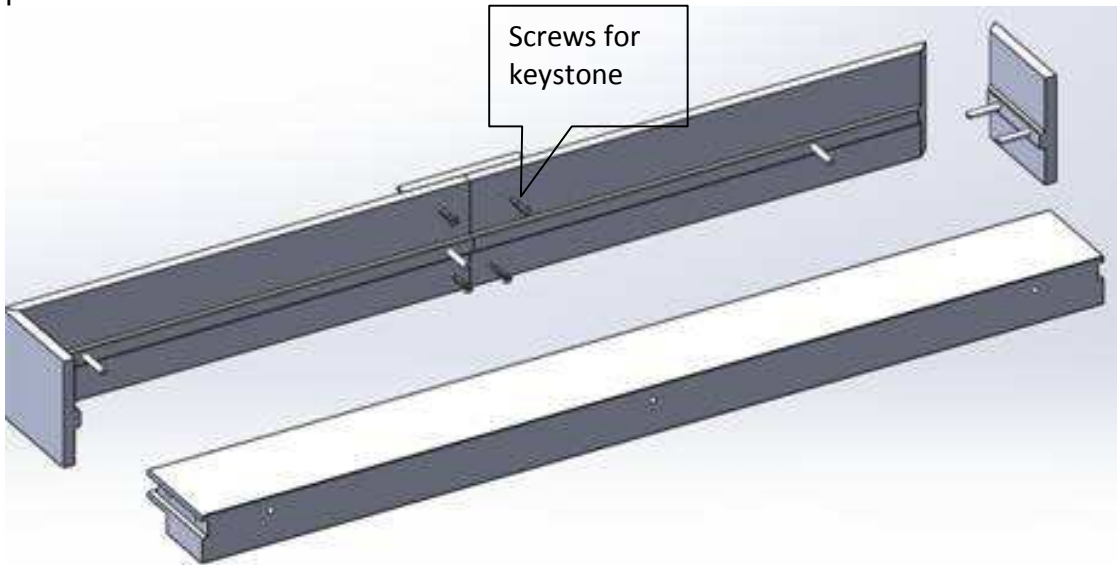

# Track Shutters—2020 Bypass



## Definitions

**Closed Bypass** - louvers must be in the closed position for panels to bypass each other when sliding.

**Open Bypass** - louvers can remain open position when panels bypass each other allowing for a clearer view when sliding.

**Combi-joined panels** - two or more panels combined or hinged together to form a single, wider sliding section, please see the drawings of where hinges will be installed.

**Note:** the interlocking bottom guide is standard on the closed bypass and optional on the open bypass.

## Guidelines and Specs:

<u>Description</u>	<u>Minimum</u>	<u>Maximum</u>		
		1 <sup>7</sup> / <sub>8</sub> "	2 <sup>1</sup> / <sub>2</sub> " , 3"	3 <sup>1</sup> / <sub>2</sub> " ; 4 <sup>1</sup> / <sub>2</sub> "
Single-Panel Width (Wood)	6"	30"	36"	42"
Single-Panel Height	10"	132"	132"	132"

### Outside Mount

Max frame-to-frame width: window width + 3"

Max frame-to-frame height: window height + 4<sup>1</sup>/<sub>2</sub>"

### Semi-Inside Mount

Max frame-to-frame width: window width - 1<sup>1</sup>/<sub>8</sub>"

Max frame-to-frame height: window height + 1 1<sup>1</sup>/<sub>8</sub>"

### Inside Mount

Max frame-to-frame width: window width - 1<sup>1</sup>/<sub>8</sub>"

Max frame-to-frame height: window height - 1<sup>1</sup>/<sub>8</sub>"

## Track Shutters—2020 Bypass

**Wheel Carriers are in the Track / Wheel Carrier Brackets are on the top of Panel:**

Adjustments to panel alignment are made by turning the wheel carrier bolt with the wrench included in the Hardware Box

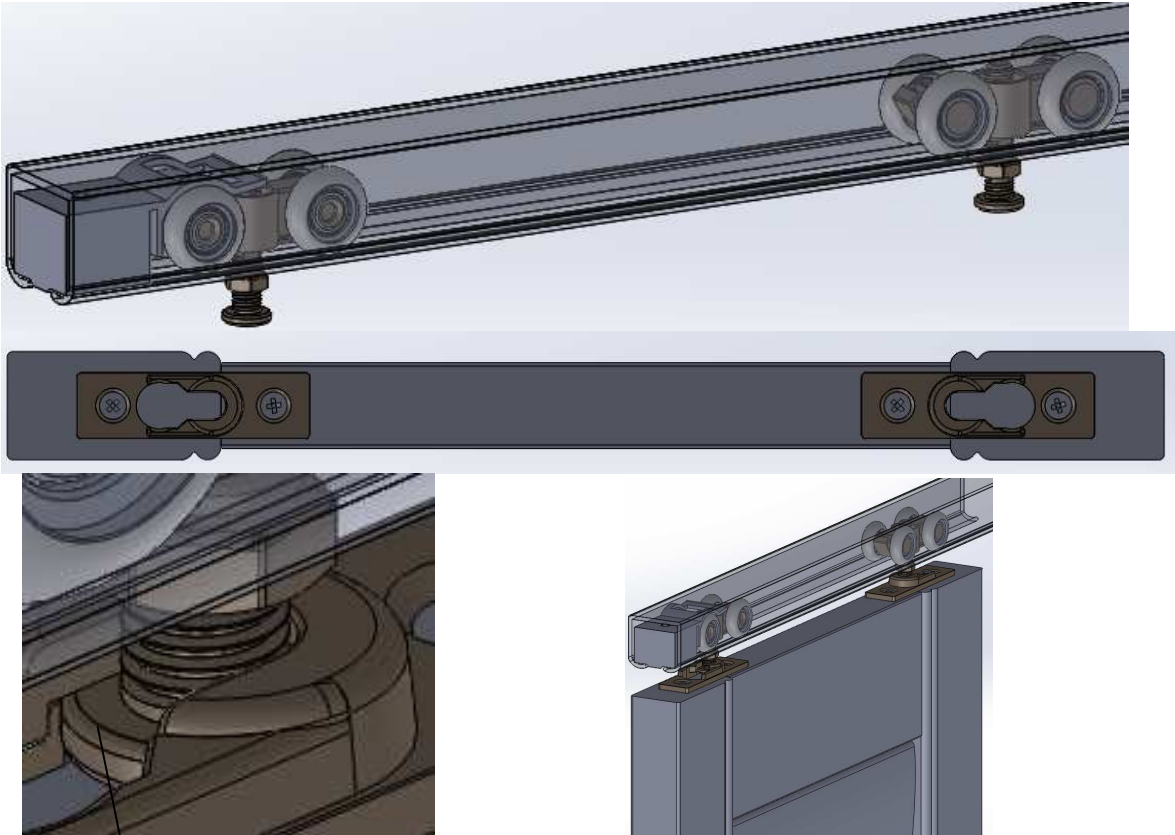

Push wheel carrier into the wheel carrier bracket to seat

Note: 2020 Stopper will be supplied at both ends of top track by default.

# Track Shutters—2020 Bypass

## Top View

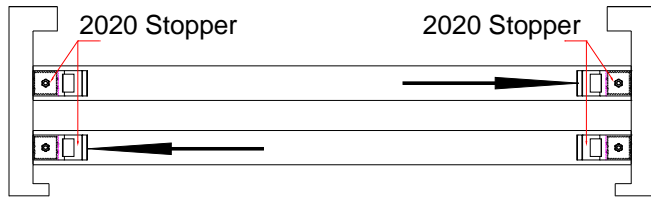

### Outside Mount

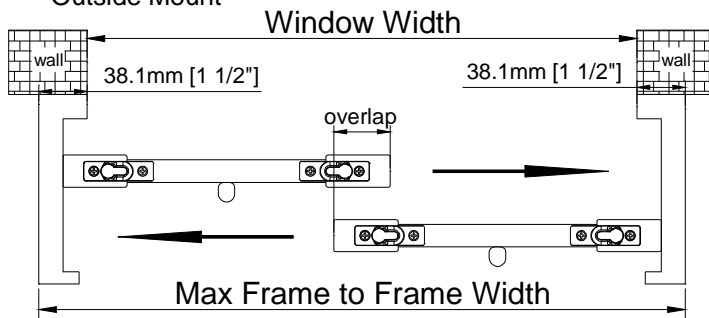

### Semi-Inside Mount

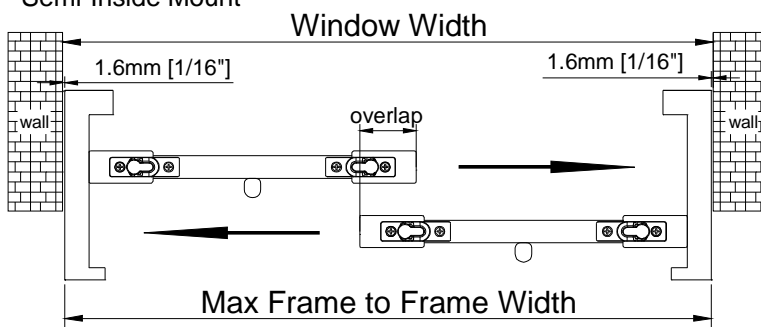

### Inside Mount

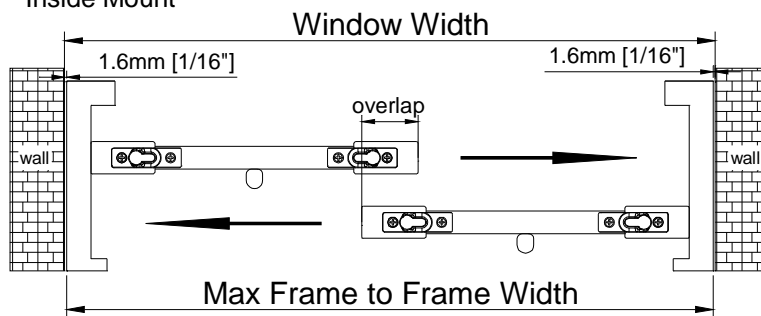

## Top View

### Combi - joined Panels:

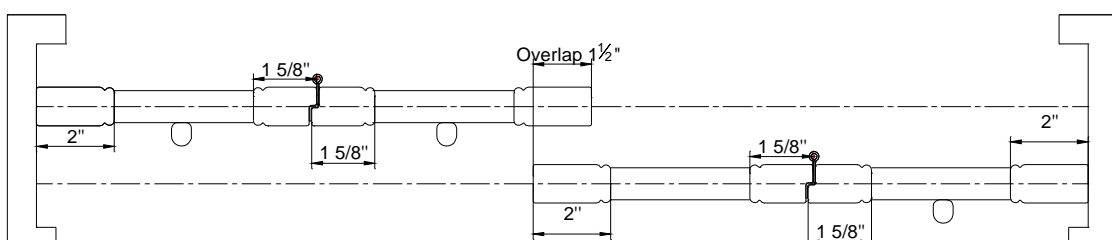

# Track Shutters—2020 Bypass

For shutters with 4 or more panels, please select “side open” or “center open”

Side Open

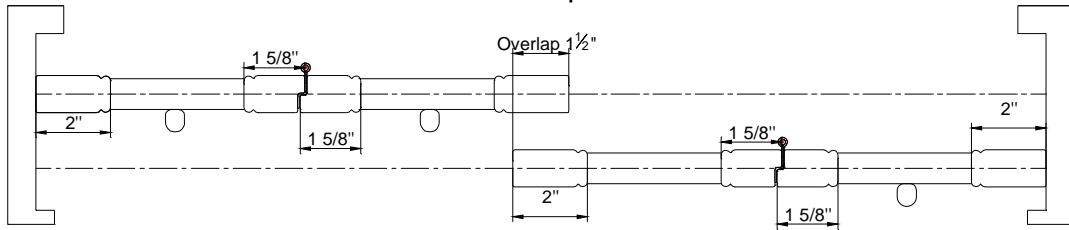

Center Open

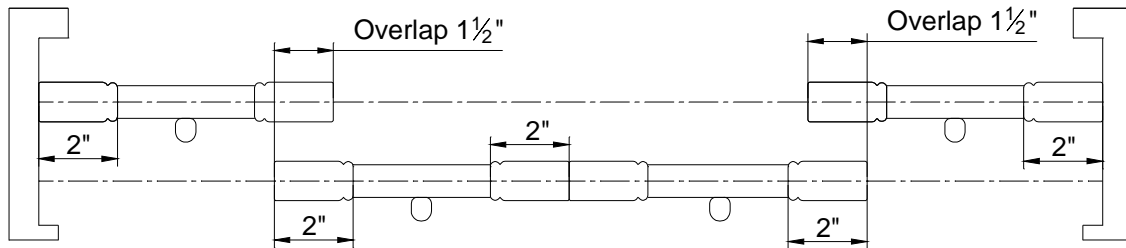

4 panels side open w/Rabbet stile

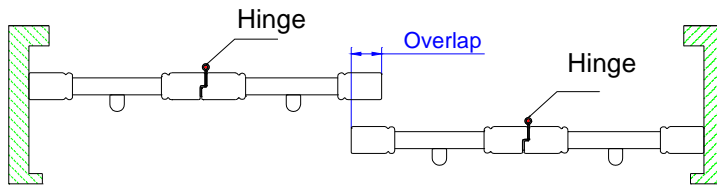

4 panels center open w/Butt stile

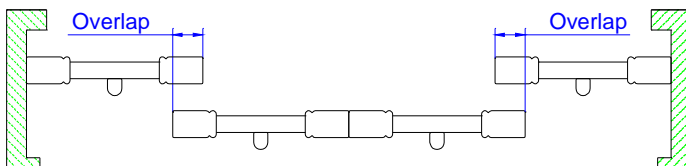

6 panels side open w/Rabbet stile

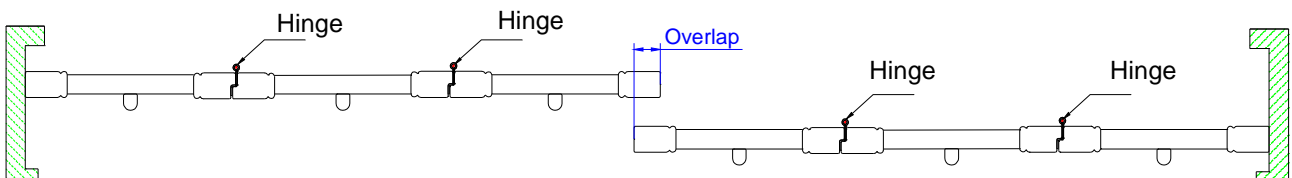

## Track Shutters—2020 Bypass

For 6 panels center open configurations, the center panels should split (1/1) by default with the option for them to be combi-joined into a single 2 panel section.

Center open Front:

### 6 panels center open w/Rabbit stile

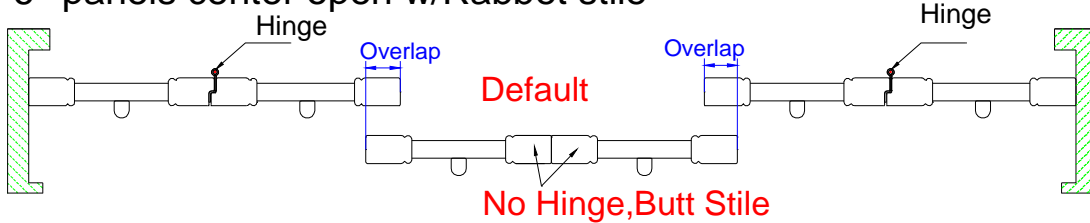

### 6 panels center open w/Rabbit stile

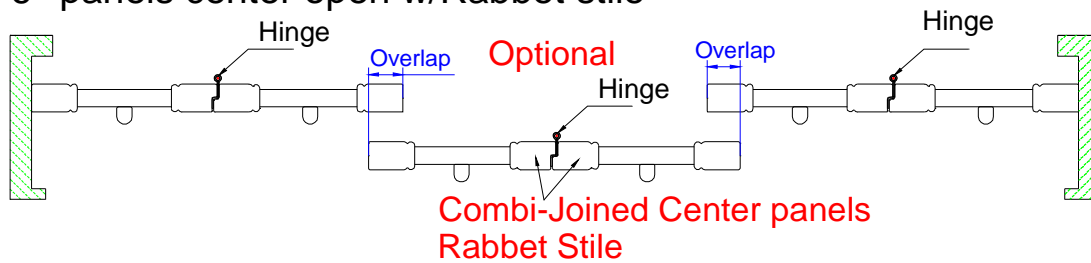

Center open Back:

### 6 panels center open back w/Rabbit stile

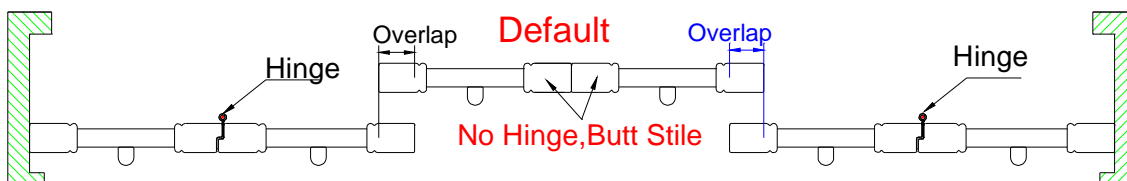

### 6 panels center open back w/Rabbit stile

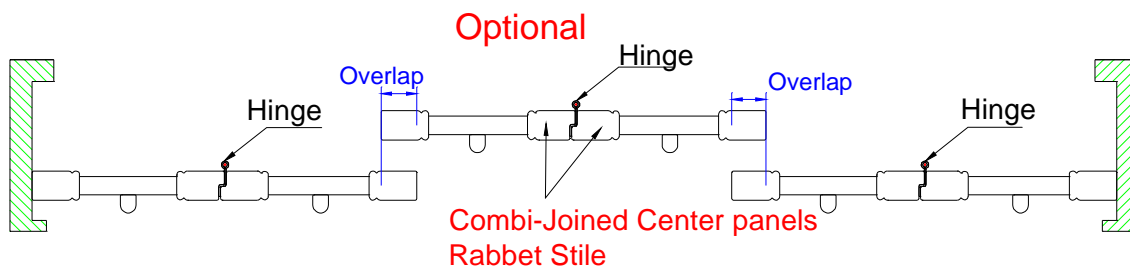

# Track Shutters—2020 Bypass

8 panels side open w/Rabbet stile

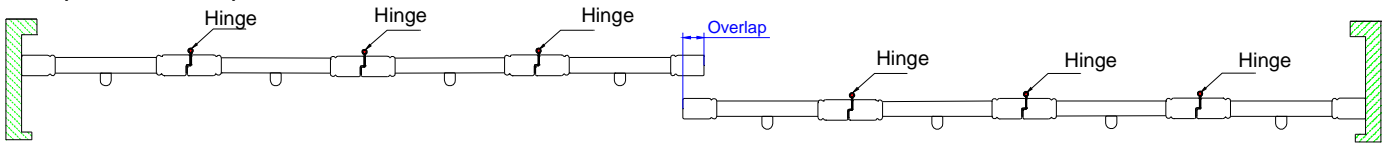

For 8 panels center open configurations, the center panels should split (2/2) by default with the option for them to be combi-joined into a single 4 panel section.

Center open Front:

8 panels center open w/Rabbet stile

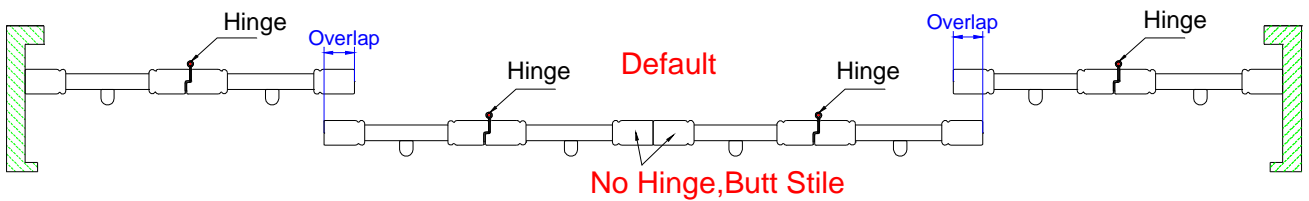

8 panels center open w/Rabbet stile

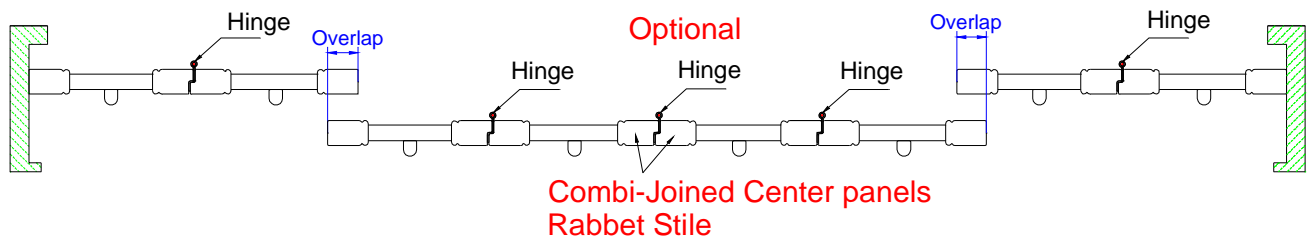

Center open Back:

8 panels center open back w/Rabbet stile

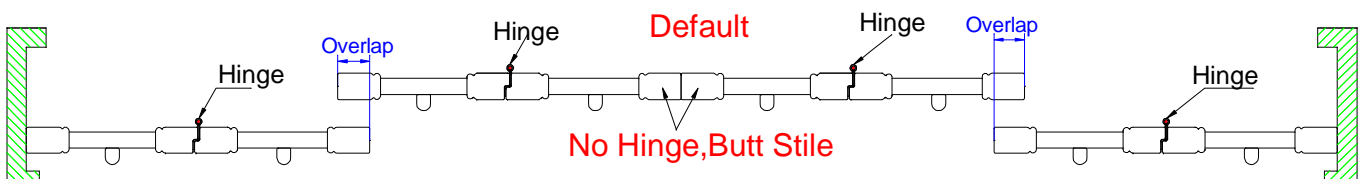

8 panels center open back w/Rabbet stile

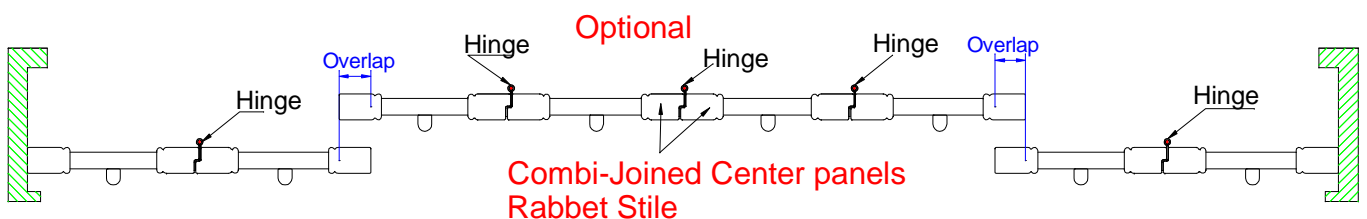

# Track Shutters—2020 Bypass

## Triple Track

### 3 panels side open w/Butt stile

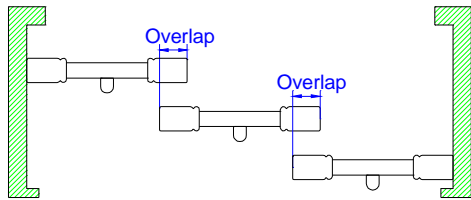

### 6 panels side open w/Rabbit stile

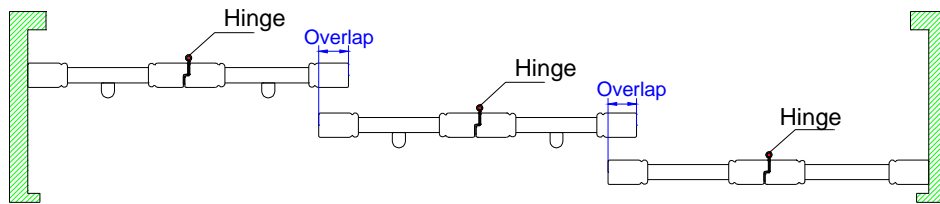

### 6 panels center open w/Butt stile

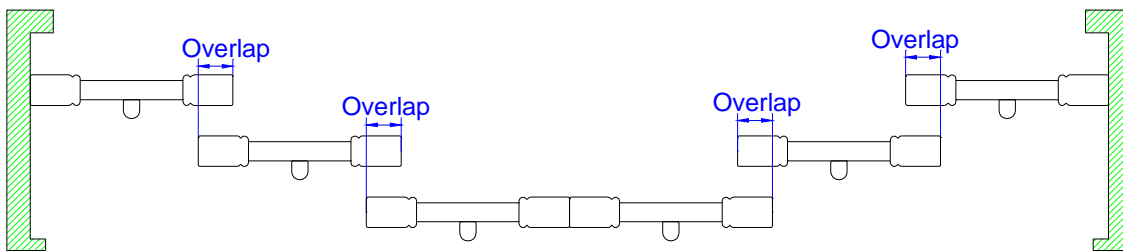

Stile: Only 2", 2 1/4" butt and rabbit stiles are available,  
1 5/8" rabbit stile only used for combi-joined panels.  
Center stile is not available.

## Open Bypass:

### 4 panels center open front w/Butt stile

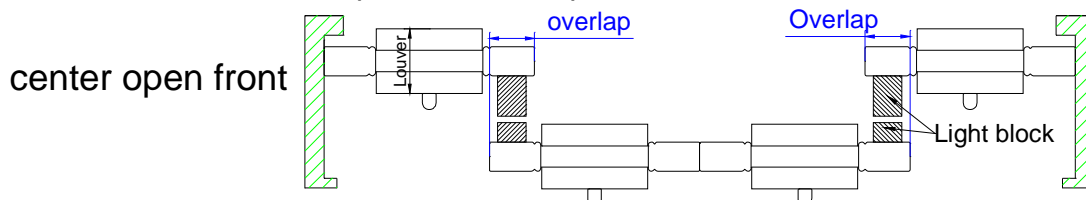

### 4 panels center open back w/Butt stile

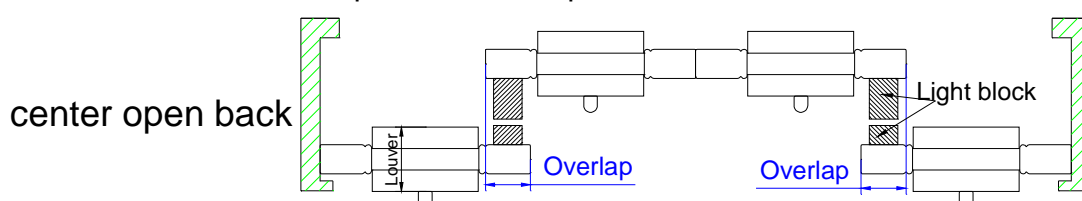



# Track Shutters—2020 Bypass

## center open front

### 6 panels center open front w/Rabbit stile

**Default**

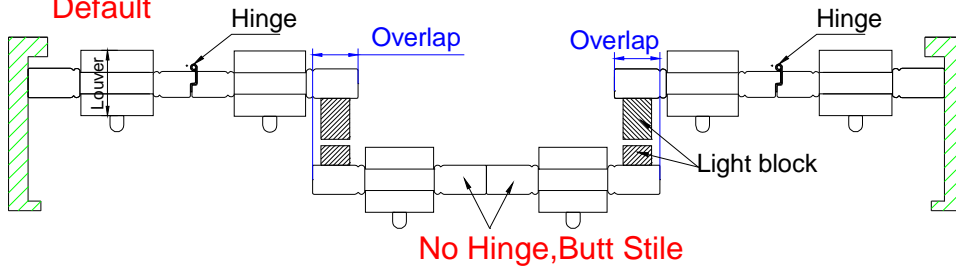

### 6 panels center open front w/Rabbit stile

**Optional**

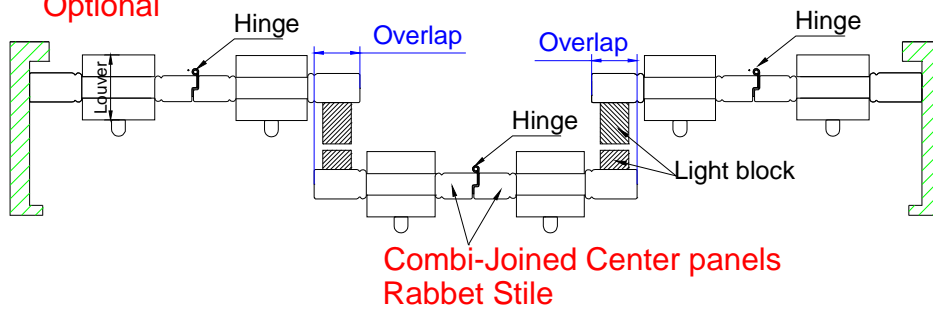

## center open back

### 6 panels center open back w/Rabbit stile

**Default**

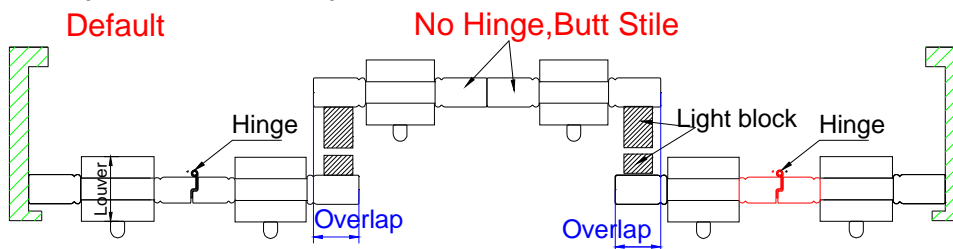

### 6 panels center open back w/Rabbit stile

**Optional**

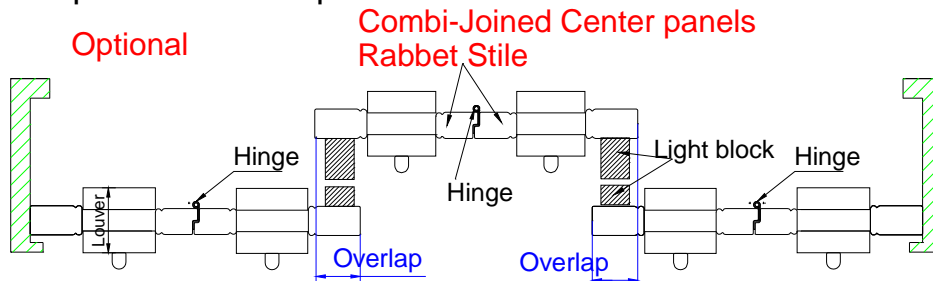

# Track Shutters—2020 Bypass

## center open front

### 8 panels center open front w/Rabbit stile

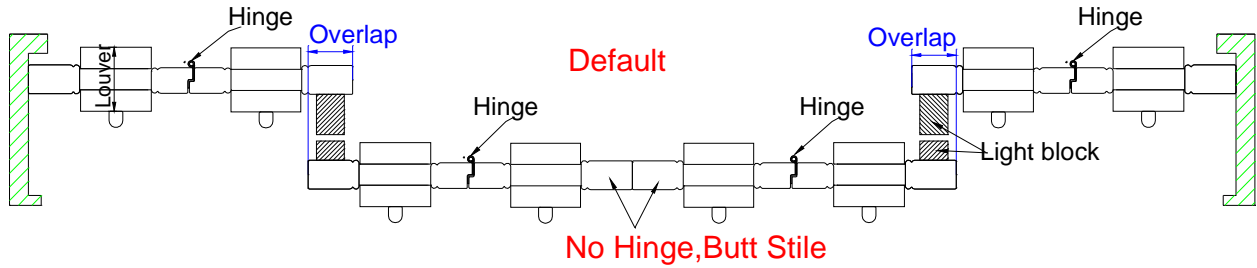

### 8 panels center open front w/Rabbit stile

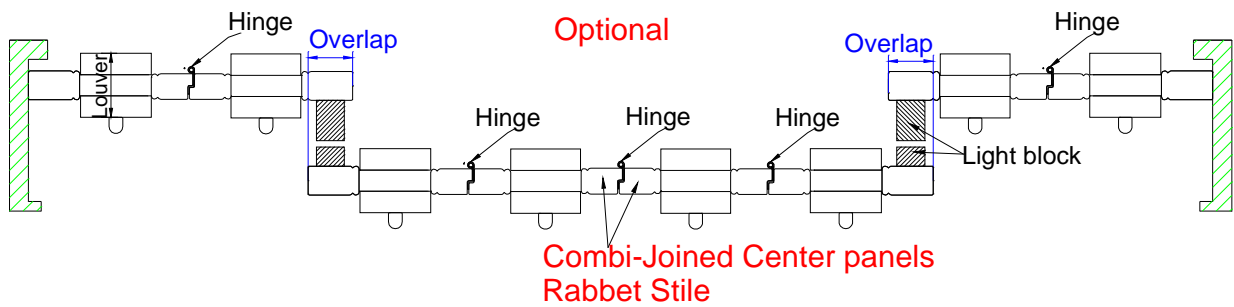

## center open back

### 8 panels center open back w/Rabbit stile

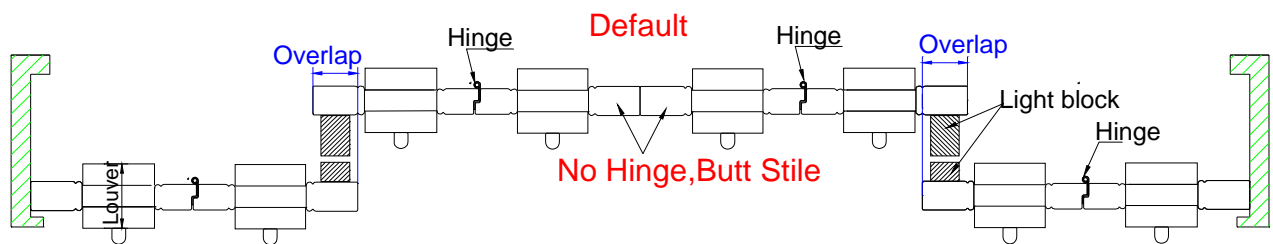

### 8 panels center open back w/Rabbit stile

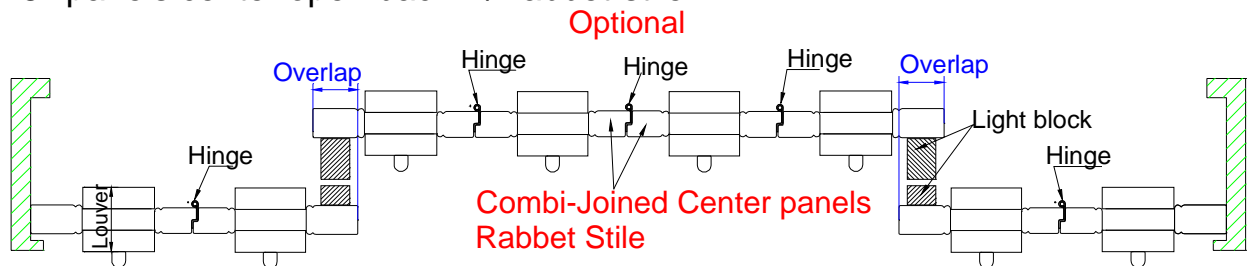

# Track Shutters—2020 Bypass

## Mounting Options (Closed Bypass)

Side View

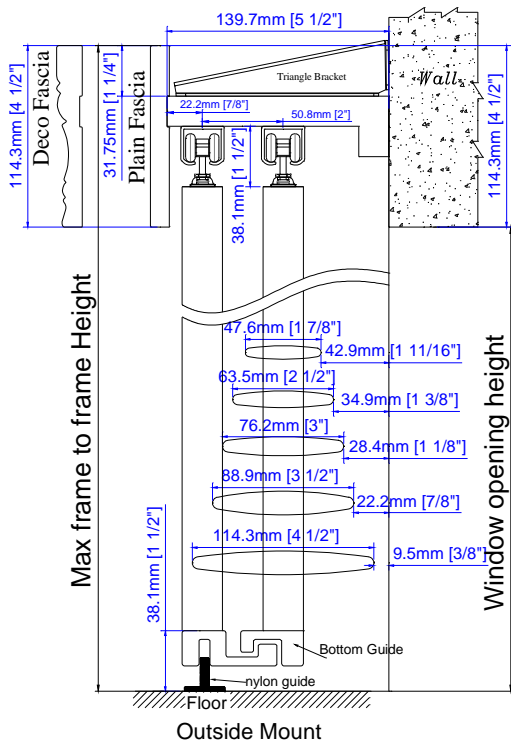

### Bottom Guide

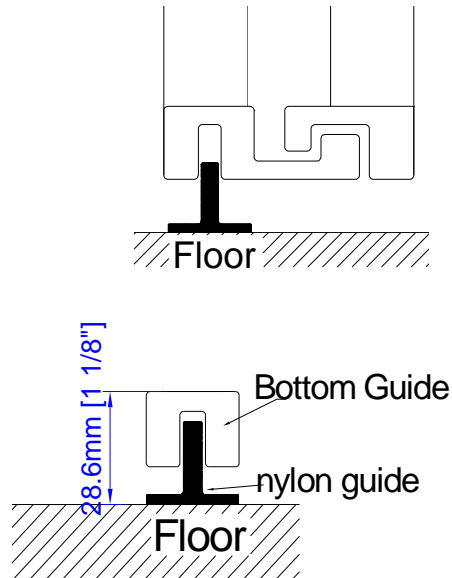

If the closed bypass only uses one track, the U-shaped bottom guide for the open bypass will be used at the bottom of the panel.

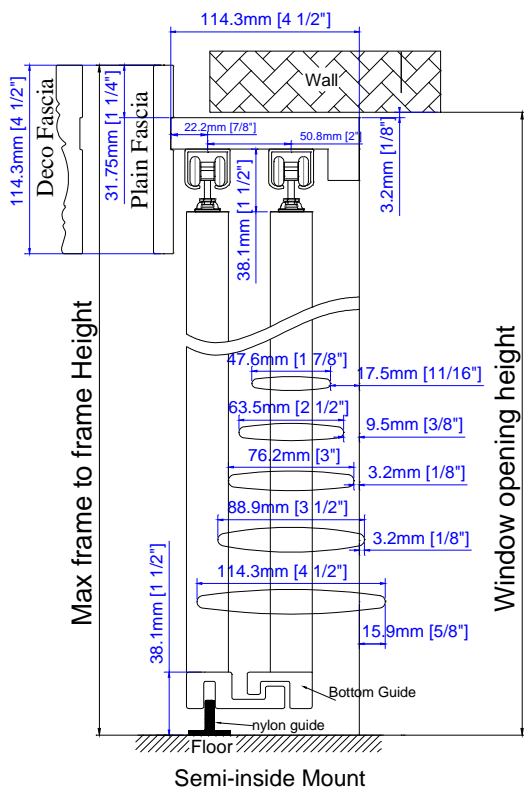

Semi-inside Mount

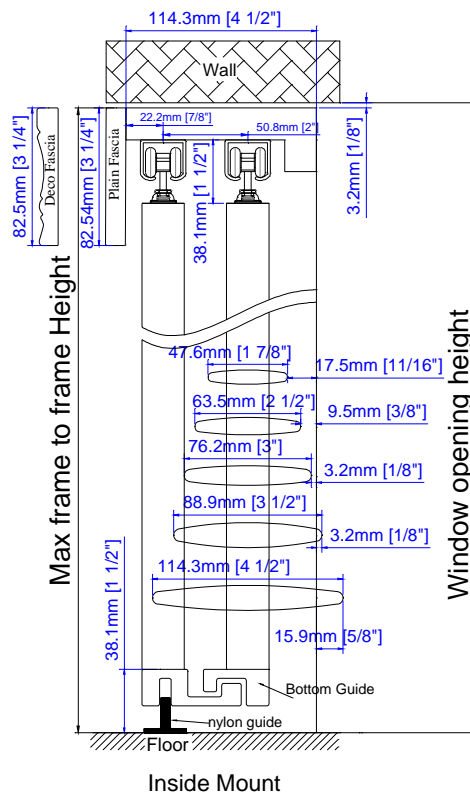

Inside Mount

# Track Shutters—2020 Bypass

## Mounting Options (Closed Bypass with 3 Tracks, Triple tracks):

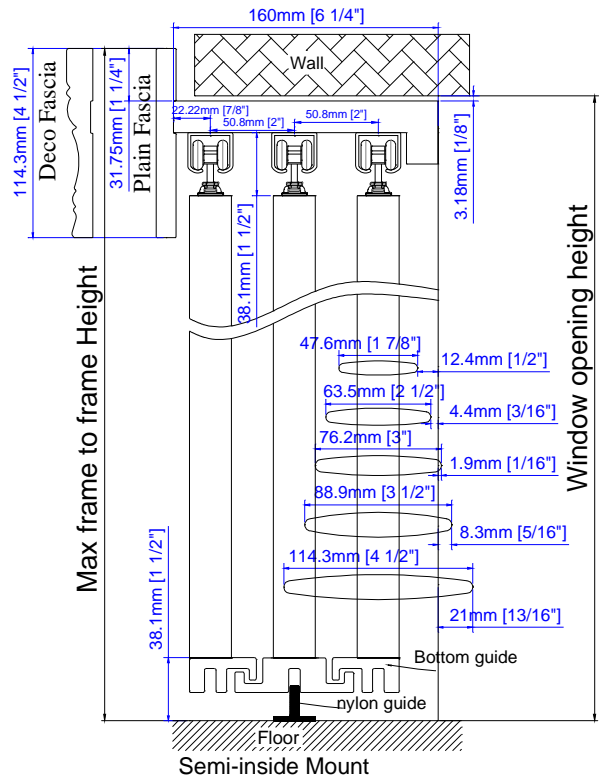
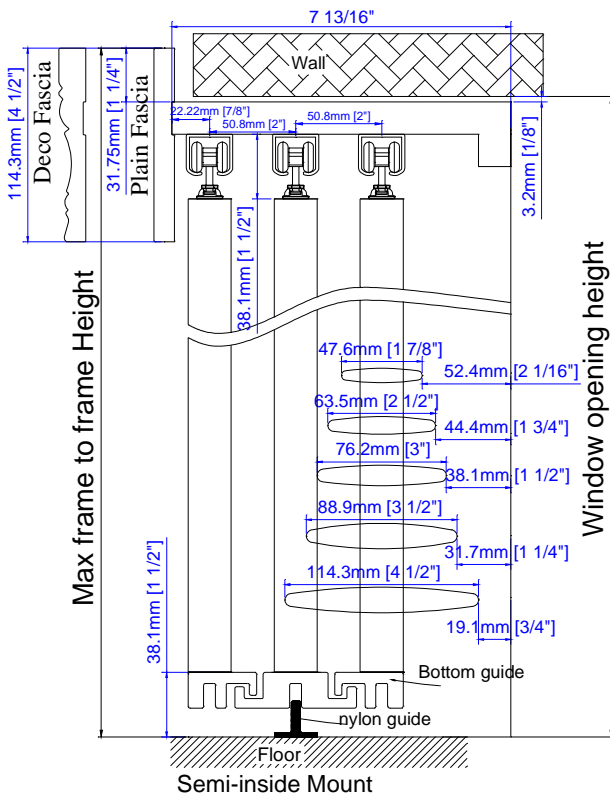
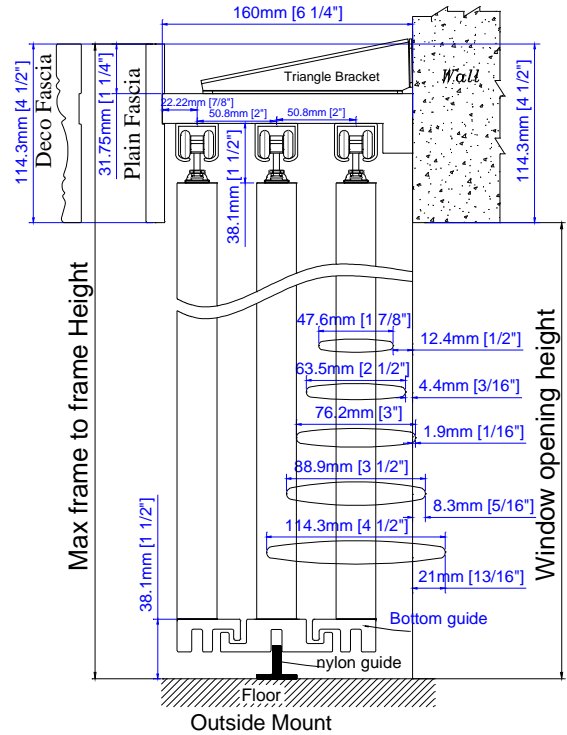
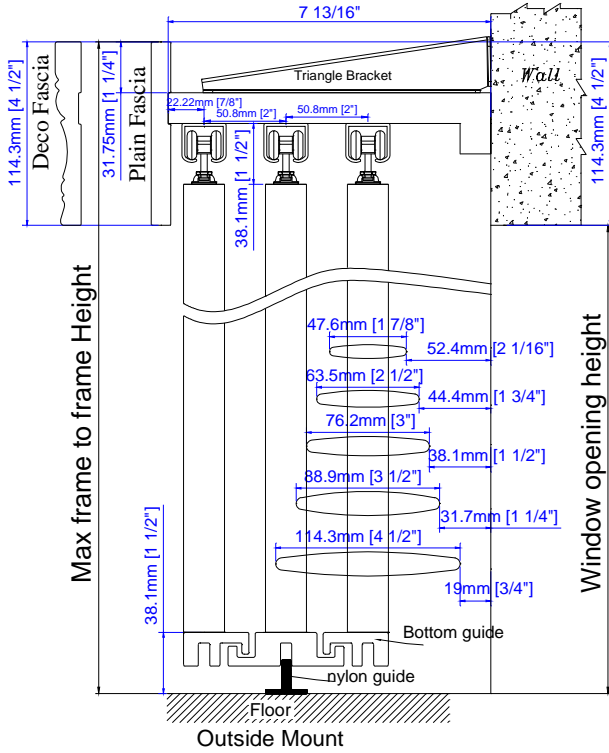

# Track Shutters—2020 Bypass

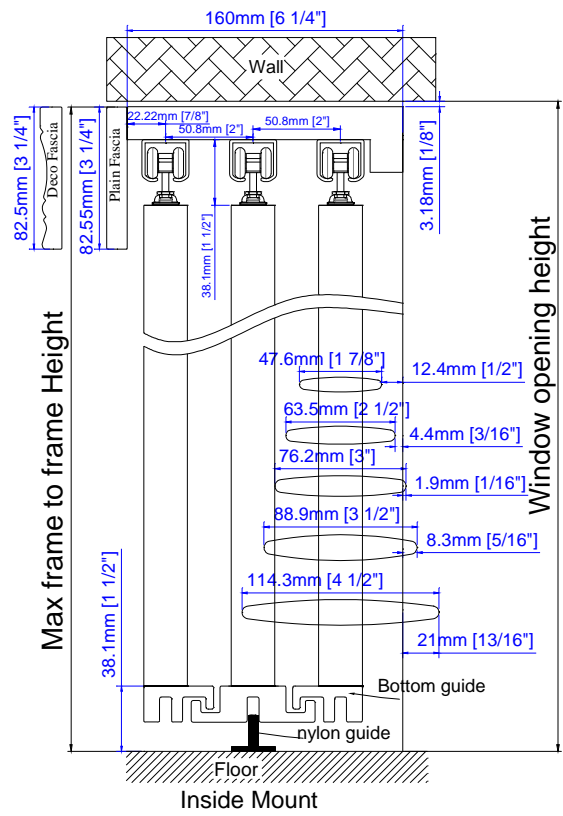
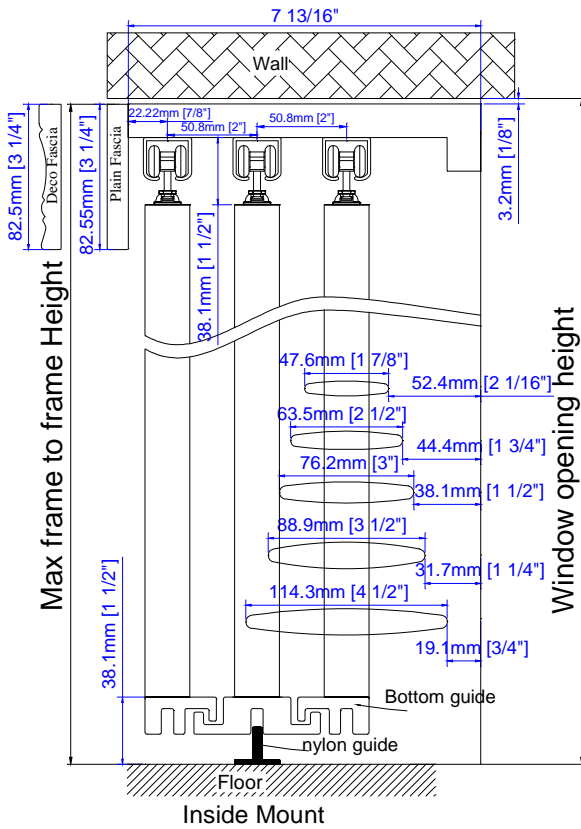

## Mounting Options (Opened Bypass)

Only available in 2 1/2", 3" and 3 1/2" louver sizes

### 2 1/2" Louver

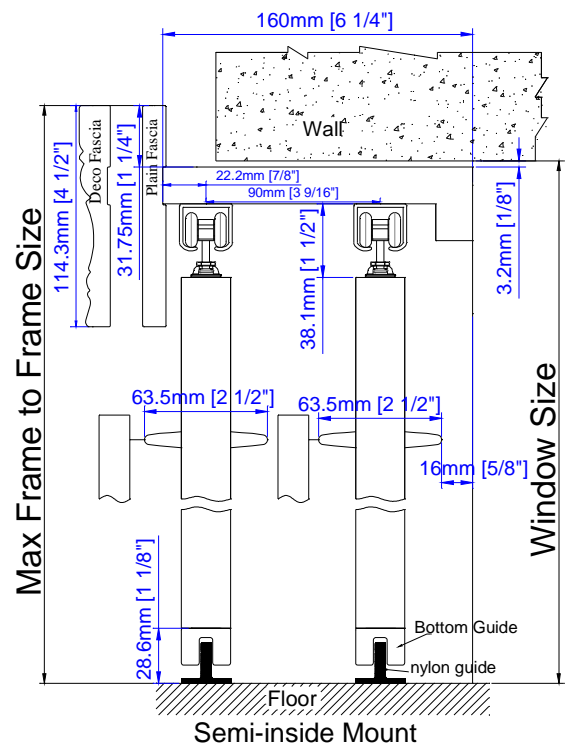
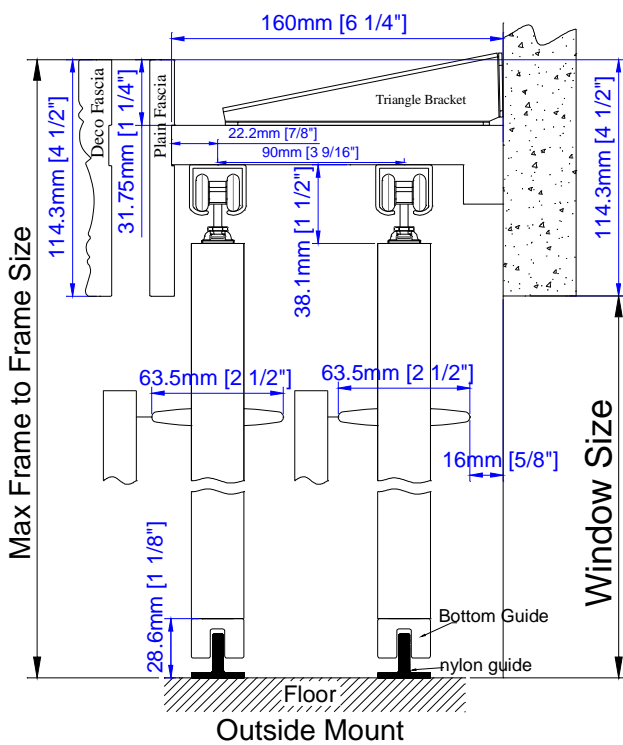

# Track Shutters—2020 Bypass

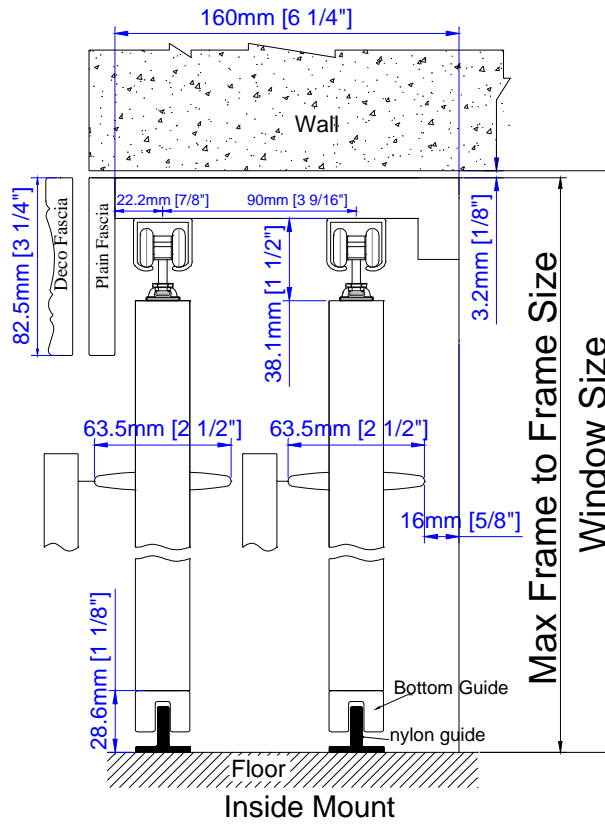

## 3" / 3 1/2" Louver

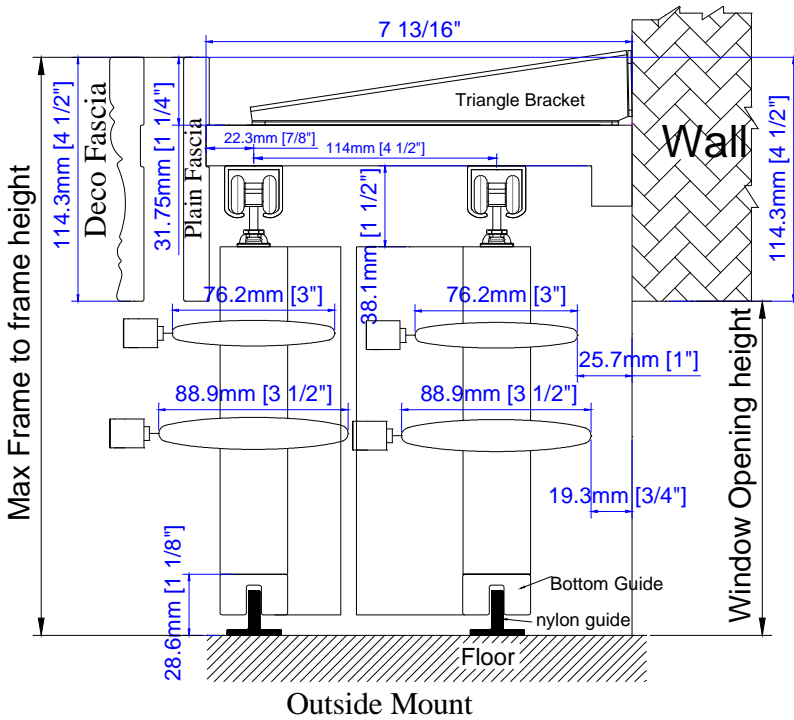

# Track Shutters—2020 Bypass

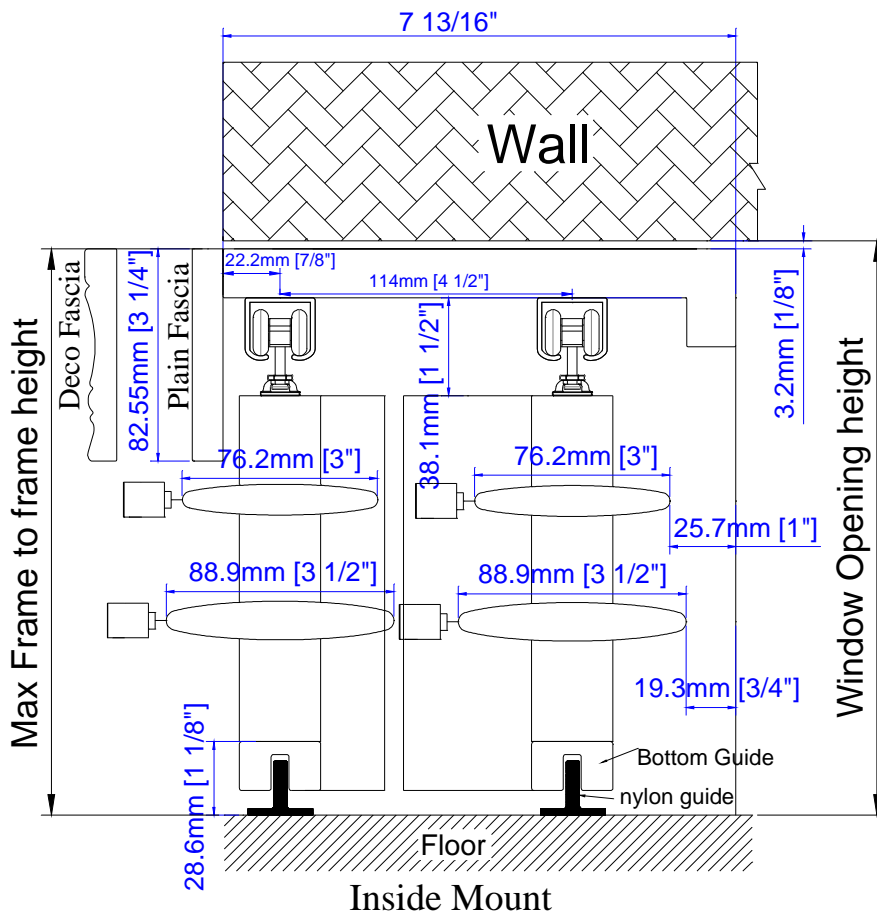
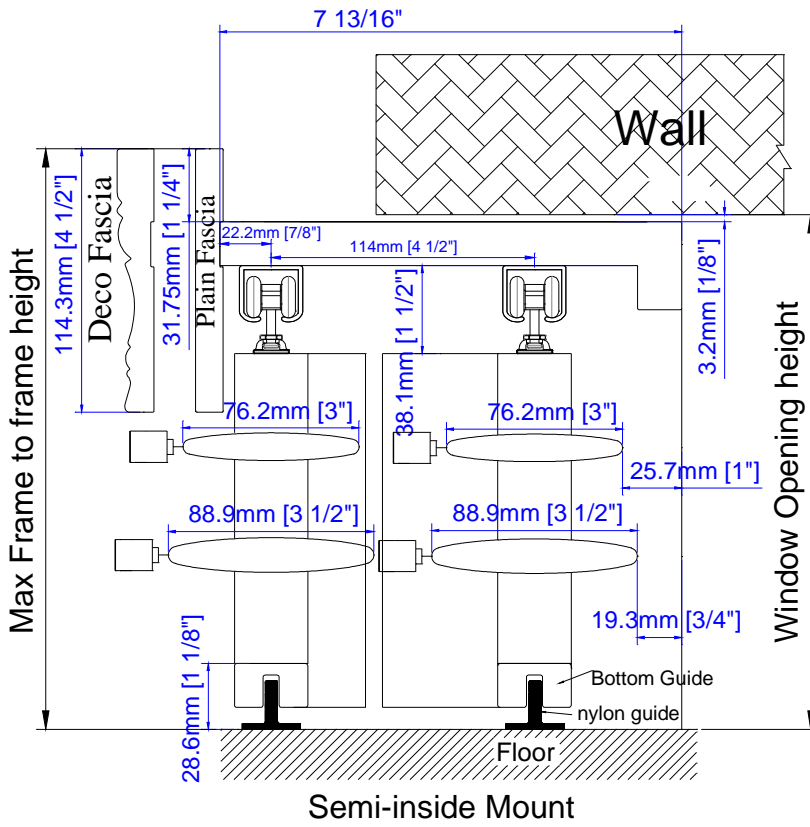

# Track Shutters—2020 Bypass

Bottom guide for Open ByPass:

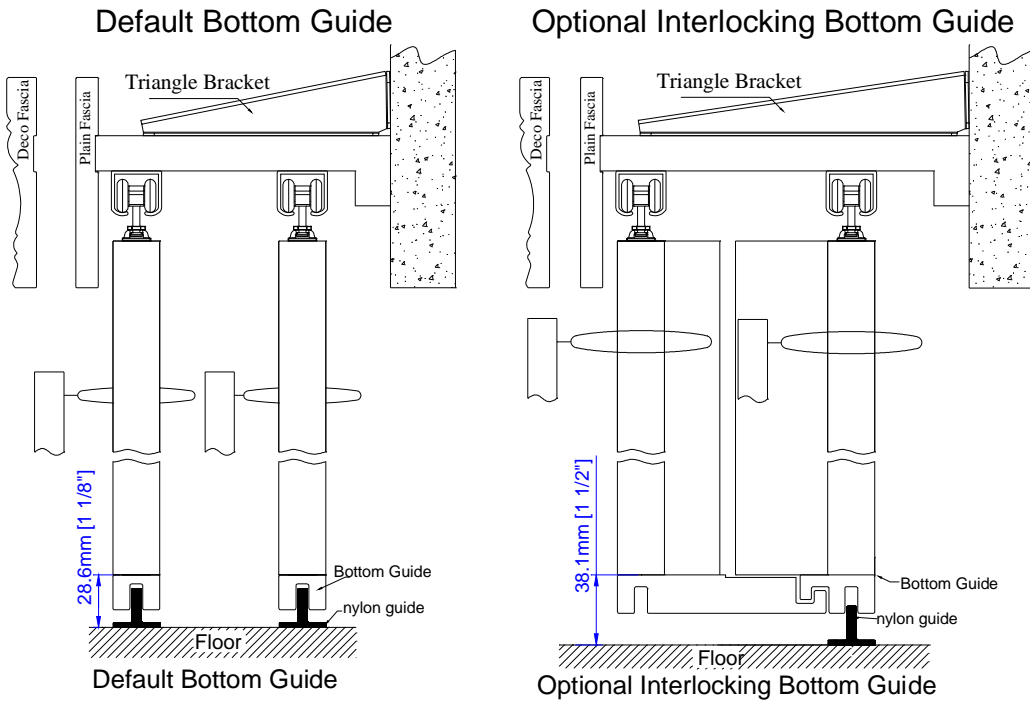

## Opened Bypass

Top View

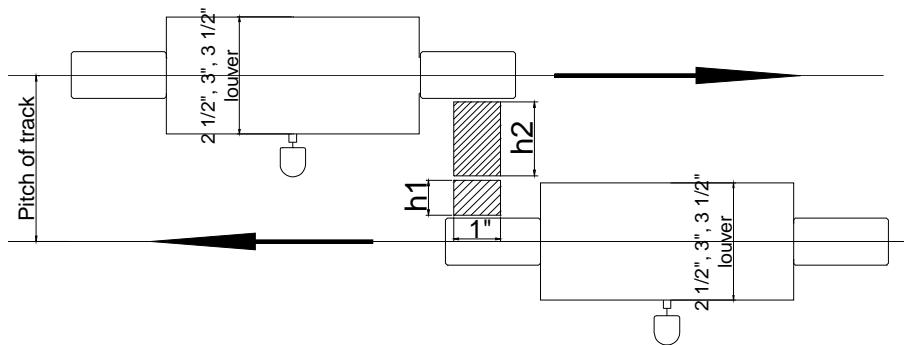

Note: The light block for open bypass will be changed to use screws with wood plugs instead of current dowels.

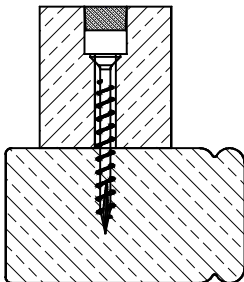



# Track Shutters—2020 Bypass



## Separation of track

Louver	U shape bottom guide		Interlocking bottom guide	
	Regular Tilt Rod	InvisibleTilt®	Regular Tilt Rod	InvisibleTilt®
2.5"	3 9/16"	2 3/4"	3 9/16"	3 9/16"
3" / 3.5"	4 1/2"	3 5/8"	4 1/2"	4 1/2"

## Light block thickness for panel

Louver		U shape bottom guide		Interlocking bottom guide	
		Regular Tilt Rod	InvisibleTilt®	Regular Tilt Rod	InvisibleTilt®
2.5"	h1	3/4"	3/4"	3/4"	3/4"
	h2	1 9/16"	3/4"	1 9/16"	1 9/16"
3" / 3.5"	h1	1 3/16"	1 3/16"	1 3/16"	1 3/16"
	h2	1 15/16"	1 3/16"	1 15/16"	1 15/16"

**Nylon Guide:** The nylon guide is composed by 2 parts and will supplied as a whole set by default (bottom part 16mm and top part 5mm), please remove the top part if necessary.

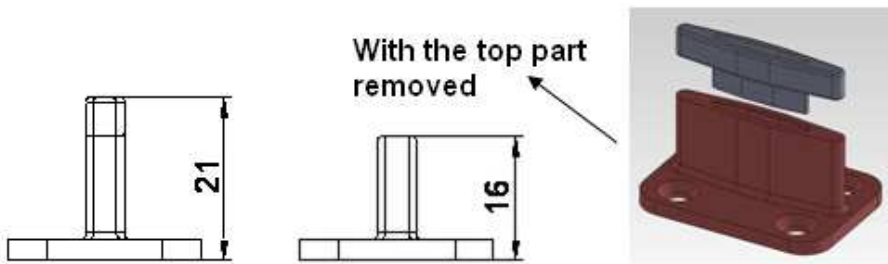

# Track Shutters—2020 Bypass

## The 2020 Stopper

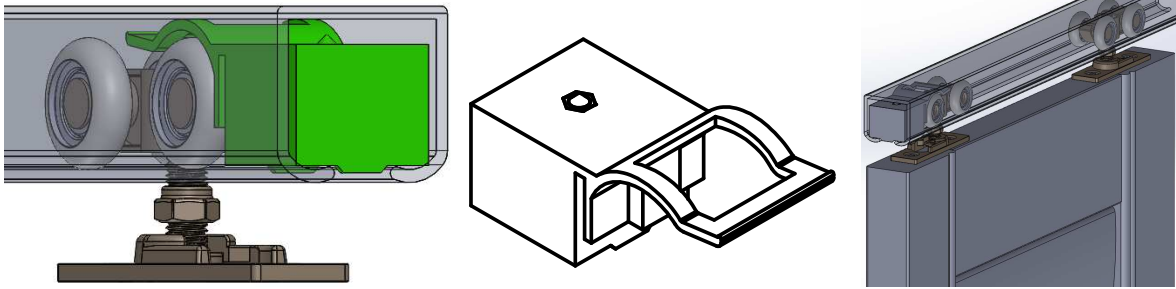

Note: 2020 Stopper will be supplied at both ends of top track by default.

The 2020 stopper can also be used in the center or any position of the top track as an option. Please specify the actual position when placing an order.

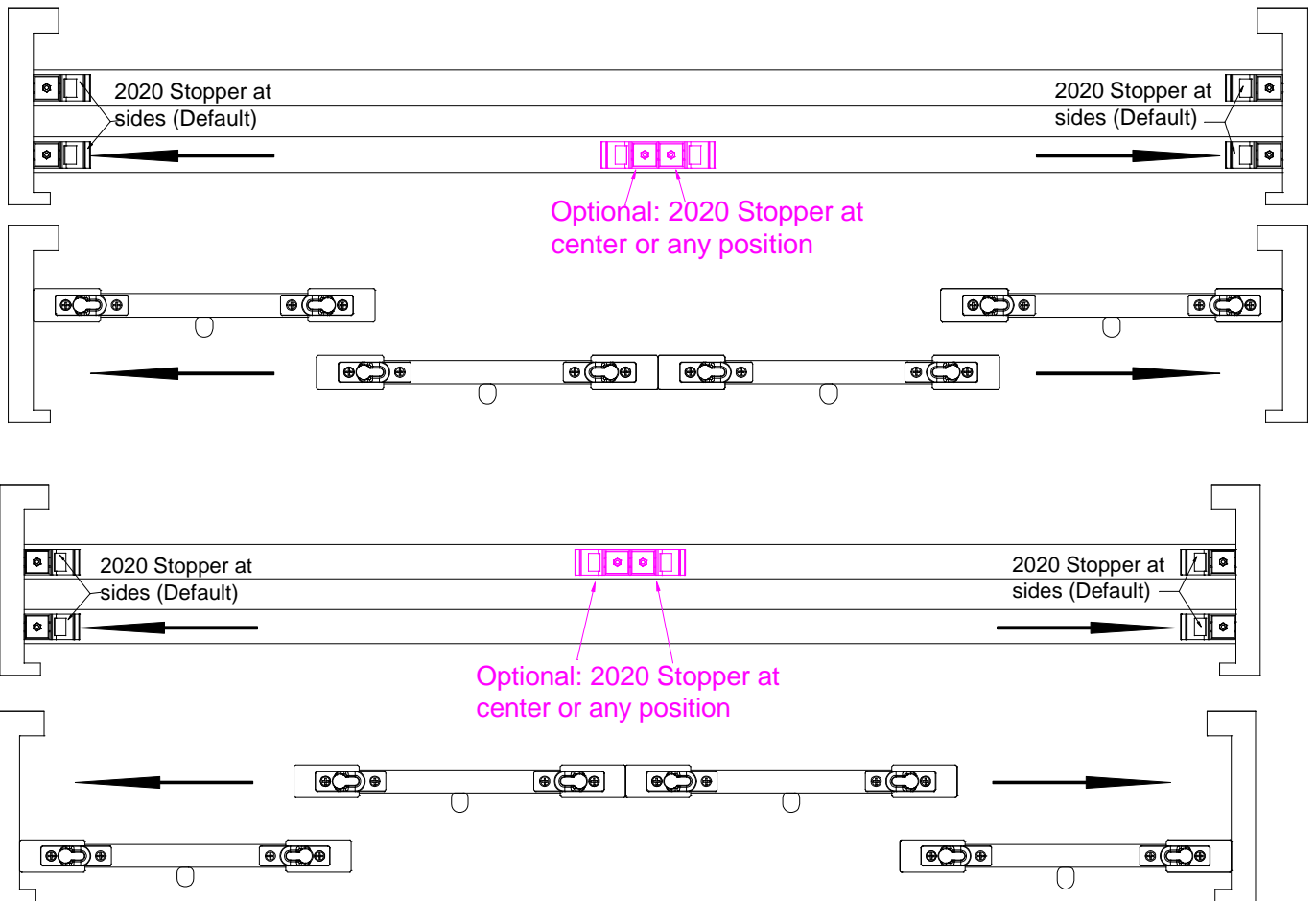

# Track Shutters—2020 Bypass



## Track Shutters Framing Materials

Framing	Size			Pc(s)	
<b>L Shape Header</b>	<b>Header (Closed Bypass)</b>	<b>Header (Opened Bypass)</b>	<b>Supporting Strip</b>	1 pc	
<b>(2 in 1)</b>	$\frac{3}{4}$ " x $5\frac{1}{2}$ "* (Default for Outside Mount; Optional for Semi-Inside and Inside Mount)	$\frac{3}{4}$ " x $6\frac{1}{4}$ "* ( $2\frac{1}{2}$ " Louver)	$\frac{3}{4}$ " x $\frac{3}{4}$ "		
Header with Supporting Strip	$\frac{3}{4}$ " x $4\frac{1}{2}$ "* (Default for Semi-Inside and Inside Mount; Optional for Outside Mount)	$\frac{3}{4}$ " x $7\frac{13}{16}$ "* (3", $3\frac{1}{2}$ " Louver)			
	Custom * $\leq$ 8"	Custom * $\leq$ 8"			
<b>U Shape Side Frame</b>	<b>Side Frame (Closed Bypass)</b>	<b>Side Frame (Opened Bypass)</b>	<b>Supporting Strip</b>	<b>Side Fascia</b>	2 pcs
<b>(3 in 1)</b>	$\frac{3}{4}$ " x $5\frac{7}{8}$ "* (Default for Outside Mount; Optional for Semi-Inside and Inside Mount)	$\frac{3}{4}$ " x $6\frac{5}{8}$ "* ( $2\frac{1}{2}$ " Louver)	$\frac{3}{4}$ " x $\frac{3}{4}$ "	$\frac{3}{8}$ " x $1\frac{1}{4}$ "	
Side Frame with Supporting Strip & Side Fascia	$\frac{3}{4}$ " x $4\frac{7}{8}$ "* (Default for Semi-Inside and Inside Mount; Optional for Outside Mount)	$\frac{3}{4}$ " x $8\frac{1}{4}$ "* (3", $3\frac{1}{2}$ " Louver)			
	Custom * $\leq$ 8"	Custom * $\leq$ 8"			
Top Fascia (Plain/Deco)	4 $\frac{1}{2}$ " (Semi-inside and Outside Mount)			1 pc	
	3 $\frac{1}{4}$ " (Inside Mount)				
Top Fascia Return	4 $\frac{1}{2}$ " (Semi-inside and Outside Mount)			2 pcs	
	N/A (Inside Mount)				

**Note:**

- When the header size is  $4\frac{1}{2}$ "\*,  $5\frac{1}{2}$ "\*,  $6\frac{1}{4}$ "\* or  $7\frac{13}{16}$ "\*, the L Shape header and the U Shape Side Frame will be sent integrally. That is:
  1. The header and the supporting strip will be sent integrally as L Shape Header;
  2. The side frame, supporting strip and the side fascia will be sent integrally as U Shape Side Frame.
- For any custom header sizes other than  $4\frac{1}{2}$ "\*,  $5\frac{1}{2}$ "\*,  $6\frac{1}{4}$ "\* or  $7\frac{13}{16}$ "\*, the L Shape Header and the U Shape Side Frame will be sent separately. That is:
  1. The header and the supporting strip will be sent separately for L Shape Header;
  2. The side frame, supporting strip and the side fascia will be sent separately for U Shape Side Frame.
- Custom Boxout Width is available for both closed and opened bypass shutters.

## Track Shutters—2020 Bypass

- For Outside Mount Bypass, the maximum custom header depth is 8", and the maximum possible header depth with an extension can be up to 8 5/8". When the standard boxout / header depth is 7 13/16", a custom extension up to 3/4" can be added to the header depth for a total maximum depth of 8 5/8".
- For Inside Mount and Semi-Inside Mount Bypass, the custom header size can reach to 8", and the extension thickness of header can reach to 2".

### Hardware Box

Hardware Box
<b>Part</b>
Wrench
Nylon Guide
3/4 " screws for Nylon Guide
Triangle Bracket (based on the length of header)
2" screws for Triangle bracket
3/4" screws for Triangle bracket

### Keystone for Fascia of the Track Shutter

When fascia length exceeds the limitation and needs to split, keystone design fascia will be supplied without surcharge for track shutters.

For fascia length within the split limitation, keystone can also be supplied as an option with surcharge.

For Deco Fascia:

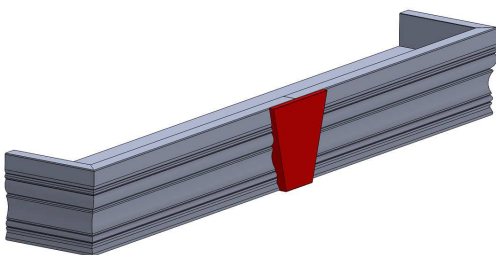

For Plain Fascia:

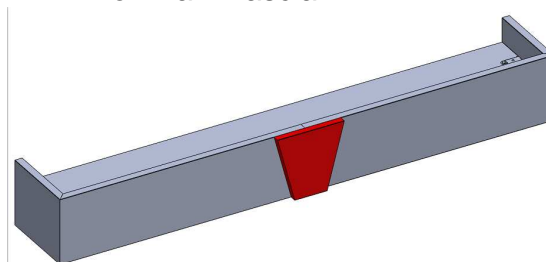

The keystone will be installed by screws. We will pre-drill the screw holes and the screws will be packed in hardware box.

## Track Shutters—2020 Bypass

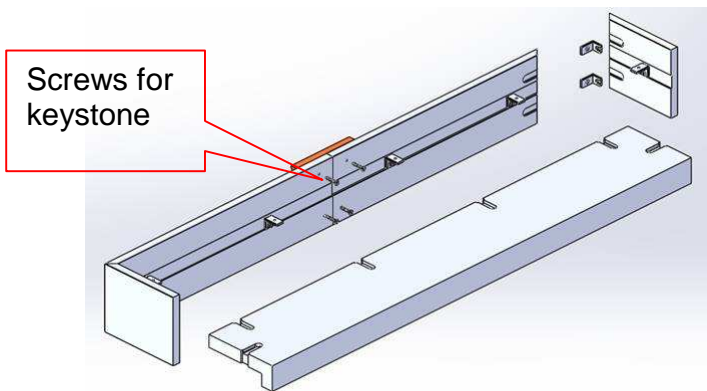

## Plastic L Bracket to Connect the Header, Fascia & Fascia Returns



L Bracket will be used to connect the header, fascia and fascia returns for Bypass shutter. This applies for Inside Mount, Semi-Inside Mount & Outside Mount.

### OM & Semi-IM

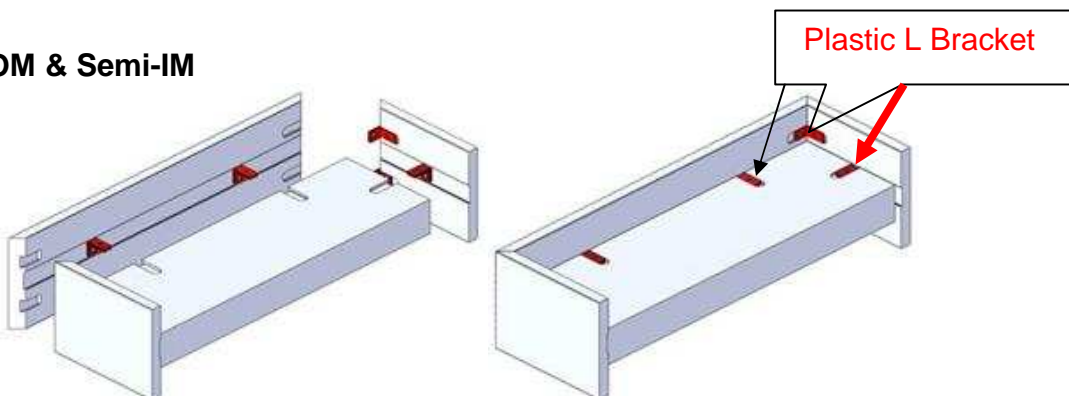

When the custom top fascia length is longer than the header length, the portion that extends beyond the header will be shared evenly between the left & right side. A plastic L bracket will be used for connecting the header to the top fascia, and also for connecting the fascia returns to the fascia. In this situation when there is a gap between the header and the fascia returns, there will not be a groove at the left and right ends of the header. Please refer to the following drawings:

# Track Shutters—2020 Bypass

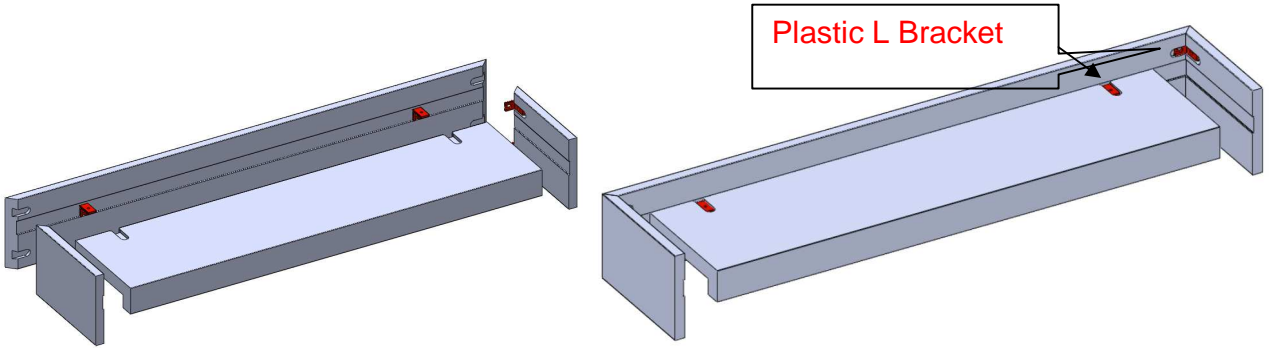

IM

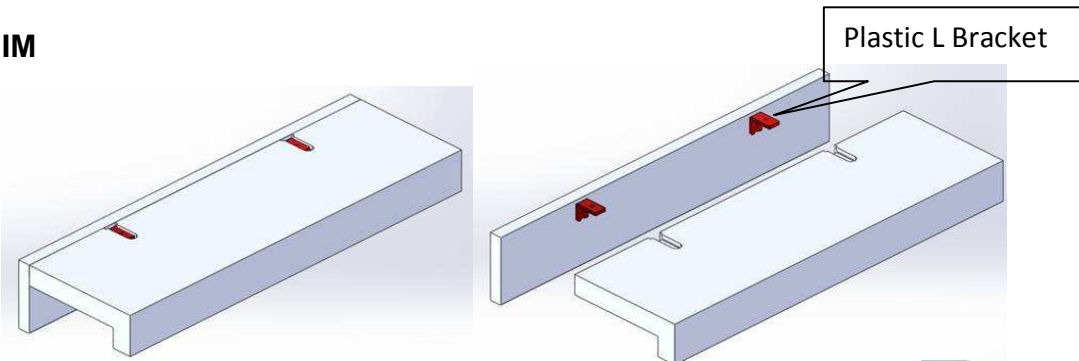

## Special Options

### Café\* Shutters

- The top of the panel requires a special finish. Please indicate “café shutter” when placing orders.
- The shutter does not come with recessed magnet on top.
- When the height of the framing material (including t-posts) exceeds the panel height, by more than 5", a surcharge will apply.

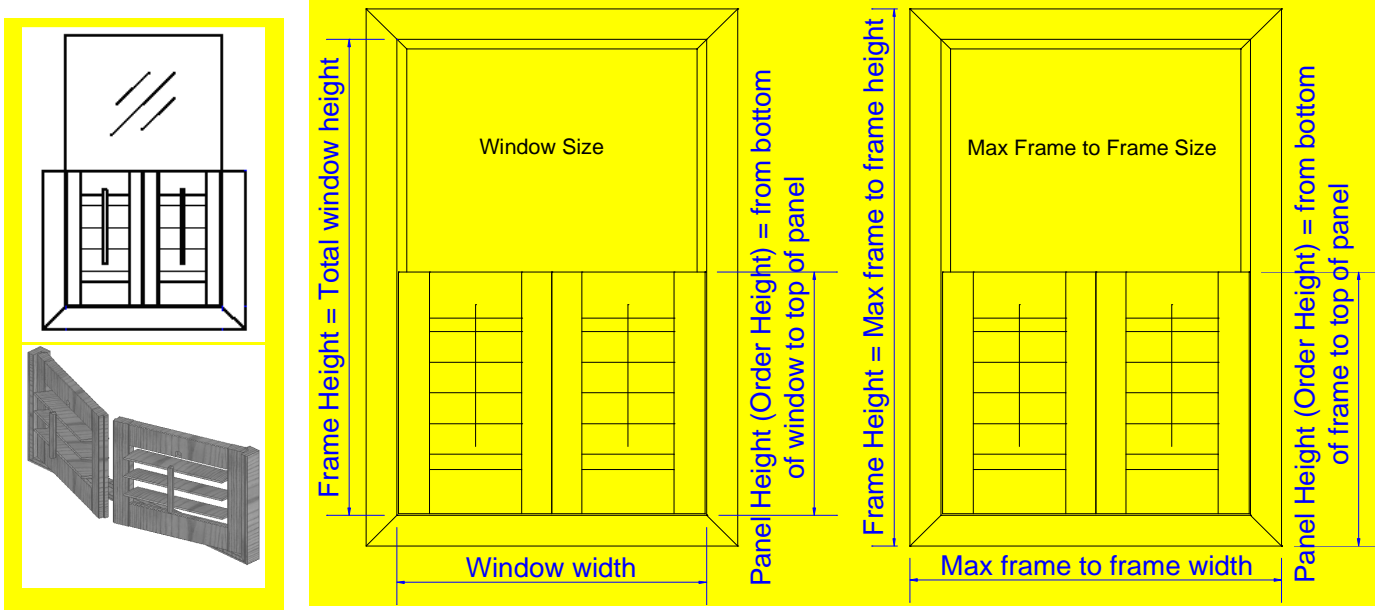

### Double-Hung\* Shutters

- For total number of panels, please include panels in both rows.
- The default location for the division point is the center unless specified otherwise.
- Horizontal T Post can be added for increased structural integrity.
- The length of Horizontal T post in each section must be less than or equal to 48".
- For Double Hung shutter, whenever an upper or lower panel is larger than 78", we will add one more extra hinge for it, we will also attempt to create larger top/bottom rails for additional strength by reducing the number of louvers by one as long as the rail sizes remain within spec.

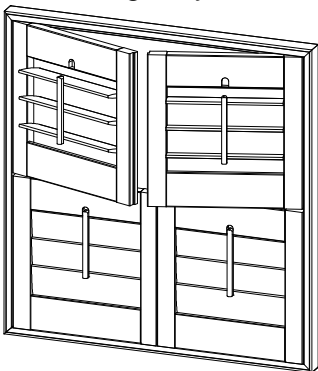

Fixed Louvers

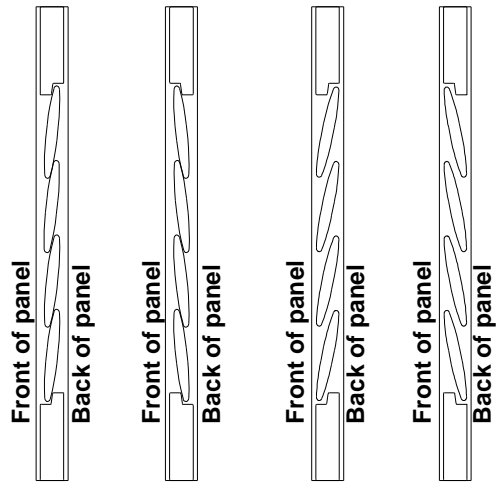
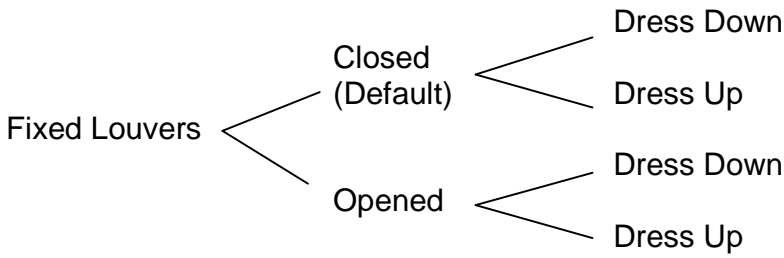

Closed, dressed down    Closed, dressed up    Opened, dressed down    Opened, dressed up

Fixed louvers Closed Dress Down and Fixed louvers Opened Dress Down are not available for all specialty shutters except all French Door Type E,F and Type A,B,C&D without fixed louver(s) which did not choose "Arch type" option.

French Door Contour Collection\*

- Flush and offset cutout options are available in both curved and square French door cutout.
  - Offset cutout is a good option for French Door with molding around the glass.
- All French door cutouts are only available in L frame except Type E and F. The batten is placed behind the Type E/F panel to block light.

Louver size	Batten Width	Batten thickness
1 7/8" & 2 1/2"	3/4"	1"
3" & 3 1/2"	3/4"	1 3/8"
4 1/2"	3/4"	1 7/8"

- For measurement details please refer to forms section.
- French Door cutouts with Arch/Quarter Arch at the top are also available except Type E and F.
- Vintage L frame with 1/4" light block and Beaded L frame with 1/4" light block are not available for French door Type A, B, C & D.

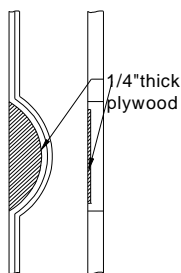

Type A

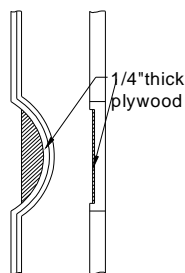

Type B

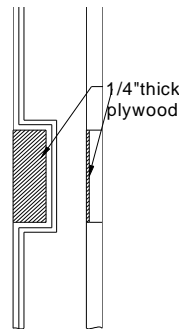

Type C

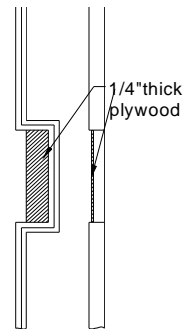

Type D

\*Some surcharges apply



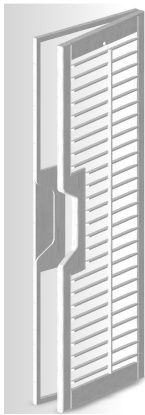

Type E

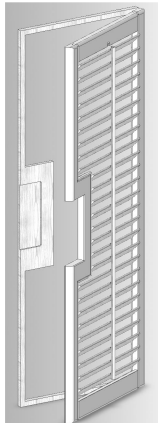

Type F

AutoTilt<sup>™</sup> (Patented) \*

Available in Bifold or Multi-fold panel configuration

Available with InvisibleTilt<sup>®</sup> Only

Available in 2" Butt, Astragal and Rabbet Stile

Minimum Louver Qty (Please see below for details)

Ring pulls included automatically. For ring pull location, please refer to the ring pull section.

Ring pulls are default. Curved Hidden and Rectangle Hidden handles are optional.

When there is only one louver section (no divider rail/no split tilt)

Louver Size	Rail Size	Minimum Louver qty
2.5"	<4.25"	6
	>=4.25"	4
3"	<3.75"	5
	>=3.75"	4
3.5"	2.75"~6.5"	4
4.5"	2.75"~6.5"	3

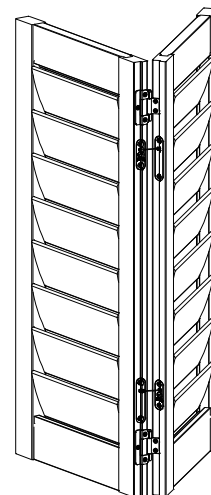

Panel with No divider rail/No split tilt

When there is more than one louver sections (with divider rail/ split tilt)

Louver Size	Rail Size	Minimum Louver qty
2.5"	<4.25"	5
	>=4.25"	4
3"	2.75"~6.5"	4
3.5"	2.75"~6.5"	3
4.5"	2.75"~6.5"	3

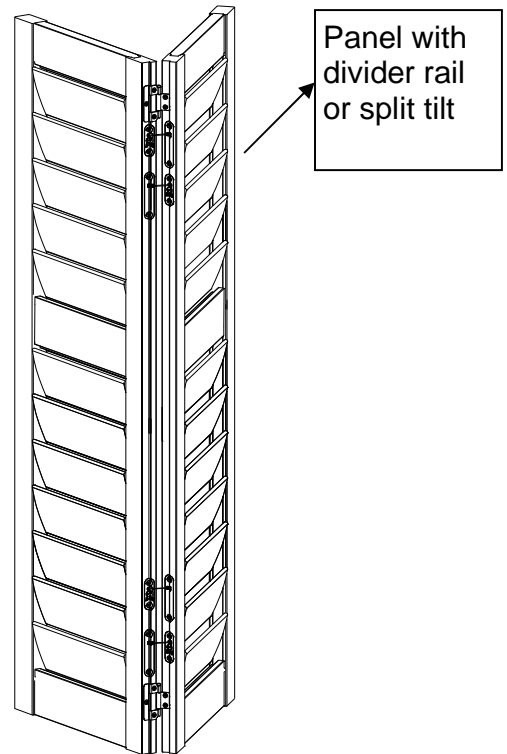

### Custom Colors \*

Available in Brightwood shutters.

Option (Color Code)	Sample Size	Confirmation Process
<b>Custom Solid (C01)</b>	A 4"x4" coated foam core or poster board.	All orders require customers to confirm an <b>actual swatch</b> which will be returned in the mail before production will commence. An additional shipping and handling fee applies.

**\*Samples sent to the factory will not be returned.**

Note:

- 1) All custom colors will be finished with the standard gloss used on all Norman products.
- 2) Please be aware that we will only be able to match the tone and not the texture or finish of the sample you submit.
- 3) Only one color revision will be allowed during the color confirmation process.
- 4) Custom color does not apply to hardware or accessories.
- 5) For custom color orders, please provide a color sample in the form of: a 4" x 4" coated foam core, a poster board if you are requesting a custom paint color, or a raw shutter louver if you are requesting a custom stain color. You are able to send in your custom color sample in a format that does not fit the three listed forms; however, please anticipate a longer lead time as the custom color sample may be required to be processed through customs. In the event that you are sending in a custom color sample that is not in the three listed formats, providing any supplemental details about the sample will assist us in getting the right color quickly, e.g. material, the Latin scientific

\*Some surcharges apply

name of the material, detail Size, a photo of the color sample, the package method, net weight, whether a premium is included in the value, certificate of origin, plant inspection certificate etc.

Due to varying materials corresponding to different colors, if a custom color sample is sent in, we will match the color on a louver and send the physical louver sample to you for confirmation. In order to streamline the process, in the event that the color variation between the physical louver swatch and the custom color sample falls outside of our acceptable range, we will verify the color digitally first with you before mailing the physical color swatch for final confirmation.

**Disclaimer:**

**Sherwin Williams ColorSnap (MWCS),  
Sherwin Williams Designer Expressions (MWDE),  
Benjamin Moore Classic (MBMC) (M2460009TL) &  
Benjamin Moore Preview (MBMP) (M2440564TL)  
Benjamin Moore, Off White Collection M2451888TL**

are registered trademarks or trademarks of their respective owners. All other trademarks mentioned herein are the property of Norman International, Inc. and/or its affiliates in the U.S. and certain other countries. Reference herein to the commercial products or service of others by trade name, trademark, manufacturer, or otherwise, does not necessarily constitute or imply its endorsement.

\*For better tracking and minimal customs delays we recommend using Fedex/DHL. Please do not use the USPS - United States Postal Service.

There are two locations you may ship your **Custom stain or Paint sample to:**

<b>DELIVER TO CHINA FACTORY For Custom Paint sample on foam core or poster board ONLY</b>		<b>DELIVER TO CHINA FACTORY For Custom Stain or Paint sample on Wood material ONLY</b>	
<b>Attention</b>	Liu Ya Yi (Shutter Factory)	<b>Attention</b>	Mr. Wang
<b>Company</b>	NienMade (DongGuan) Window Fashions Co., Ltd.  No. 1, Zhao Feng Industrial South Road, QiShi Town, DongGuan City, GuangDong Province China 523517	<b>Company</b>	Draco Logistics Co., Ltd.  Unit 616, 6/F, Pacific Trade Centre No.2 Kai Hing Road Kowloon Bay, Hong Kong, China, 999077
<b>Telephone:</b>	+86-769-867-16666	<b>Telephone:</b>	26283018

## Specialties

### Specialty Shutters\*

Specialty shutters are made of premium solid wood, finished to match the beauty of all Norman shutters. Templates are required if it is an imperfect specialty. Please refer to Specialties and Template Requirement sections for details.

Regarding frame with an insert or solid frame issue:

- 1). For Half Round Sunburst, Quarter Round Sunburst, Eyebrow Sunburst & Elongated Eyebrow Sunburst:
  - All deco frames will be made as solid frames;
  - All Vintage L frames & Vintage hang strip: all top frames (curve shape frame) will be made as a solid frame but the bottom & both sided frames (straight frames) will be made as regular frames with inserts
- 2). For Triangle, Hexagon, Octagon, Peak & Angle top: all frames will be made as regular frames with inserts.
- 3). For Circle, Oval: all frames will be made as solid frames (not with an insert).
- 4). For Sunburst on top with Divider strip: the top frame (curve shape frame) will be made as a solid frame but the bottom & both side frames (straight frames) will be made as regular frames with inserts.
- 5). For Louver Arch with Eyebrow curve shape:
  - All deco frames excluding 2.5" Mission deco frame: all frames will be made as solid frames (not with an insert).
  - All Vintage L frames & Vintage hang strip & 2.5" Mission deco frame: the top frame (curve shape frame) will be made as a solid frame but the bottom & both sided frames (straight frames) will be made as regular frames with inserts;
- 6). For other Specialty Shutters when curve shape is similar as perfect arch (such as Louver Arch except Louver Arch with Eyebrow curve shape in point 5), Horizontal louvers center arch with quarter round side panels(-Standard louvered arch & Continuous arch), Sunburst louvers center arch with quarter round side panels, Arch Top Picture Window with horizontal louvers, Arch Top Picture Window with Sunburst, Standard unit with horizontal arch center etc.):
  - All deco frames will be made as solid frames;
  - All Vintage L frames & Vintage hang strip: all top frames (curve shape frame) will be made as a solid frame but the bottom & both sided frames (straight frames) will be made as regular frames with inserts.
- 7). Tilt Out Z Frame is not available for "Frame Include In Rail" option.
- 8). Hang strip behind the panel is not available for Hexagon and octagon with horizontal louvers.
- 9). All sunburst hubs must be less than or equal to 12".
- 10). If a requested half round sunburst arch will result in louvers that are out of spec, a center stile may be added in order to produce the unit.

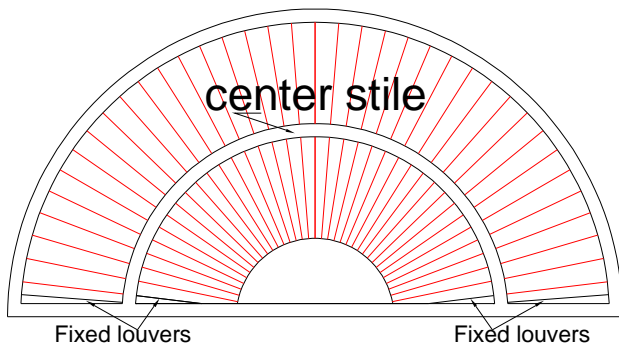

The louvers in the curved section can not be operated by the Invisible Tilt system. They can be independently operated by a separate standard tilt rod installed on back of the panel.

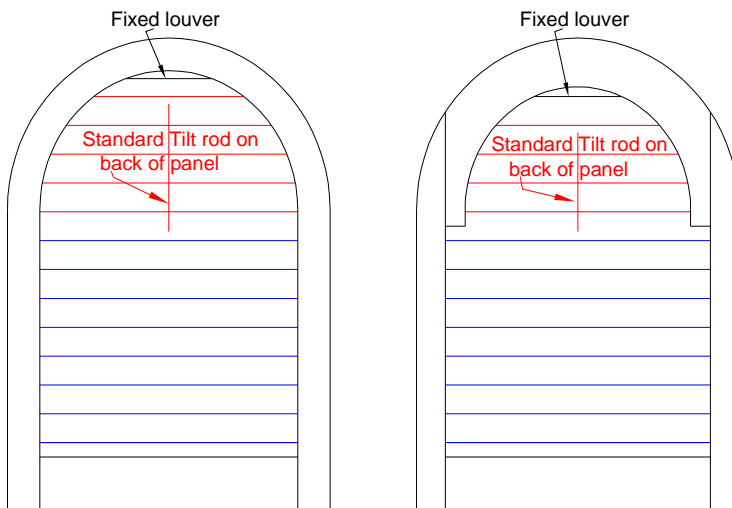

**Frame include in Rail (Z Frame only, exclude Tilt Out Z Frame)**

With the frame included in rail option, there is no rail or stile on the panel. Instead, the panel's louvers are connected directly to the inside edge of the Z frame around the outer perimeter, so the Z frame acts as the "rail & stile". For this reason, the panel will not have any magnets or hinges, since it is a fixed panel.

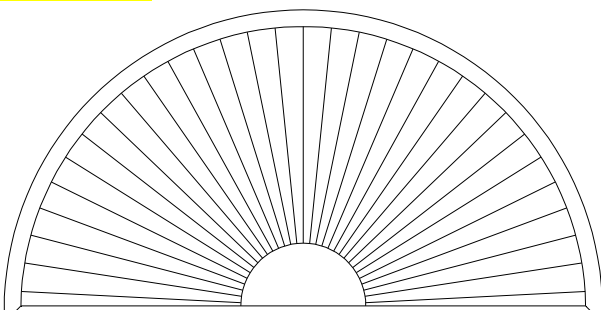

Available frame types: 3" Crown Z Frame, 2" Bel Air Z Frame, 2" Bullnose Z Frame, 1 1/4 Beaded Z Frame, 1 1/2 Bullnose Z Frame.

Available specialty types: Half Round Sunburst, Eyebrow Sunburst, Elongated Eyebrow Sunburst, Left Quarter Round Sunburst, Right Quarter Round Sunburst, Sunburst on Top with Divider Strip (Frame Include in Rail Z Frame Only), Circle Sunburst, Hexagon Sunburst, Hexagon Sunburst with Straight Sides, Octagon Sunburst, Peak Sunburst.

\*Some surcharges apply

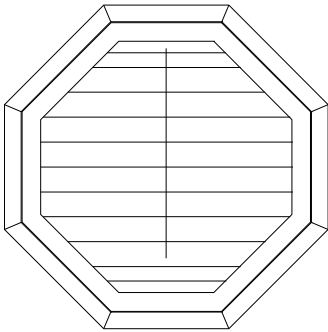

The left and right vertical stiles cannot be less than 8.125" (for 2.375" series hinges) for the panel to have hinges on the outer left and/or right stiles with L / R / LR / LTR configurations. For stiles less than 8.125" (for 2.375" series hinges) tall, the configuration must be RTL with panels hinged to the T post.

For all specialty shape shutters, if the hinges are required, the smallest vertical stile straight height (net panel leg height) must be greater than 8 1/8" (for 2.375" series hinges) / 9 3/4" (for Direct Mount 3" hinge) to allow for hinge installation.

The limitations of these custom-made specialty shutters shown below are an approximate range. Actual limitations and availability vary depending on the width to height relationship, frame type, stile size, etc. This chart is used for general reference only.

	Min Width	Max Width	Height
Eyebrow Sunburst			Height needs to be greater than 1/5 of the width
Elongated Eyebrow Sunburst	20"	80"	Curve Height needs to be greater than 1/5 of the width
Half Round Sunburst			Height needs to be greater than 1/3 of the width & within 10" and 40"

Eyebrow Sunburst

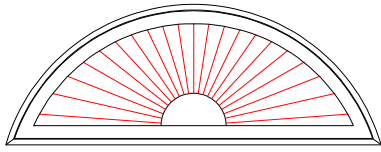

Elongated Eyebrow Sunburst

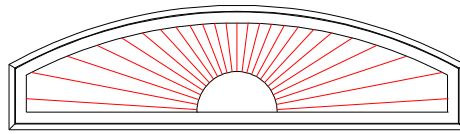

Half Round Sunburst

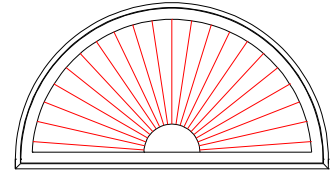

Half Round with Horizontal Louvers

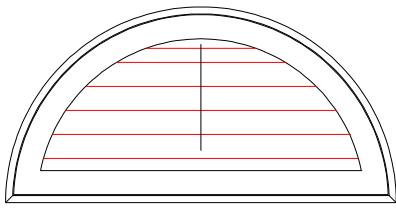

Left Quarter Round Sunburst

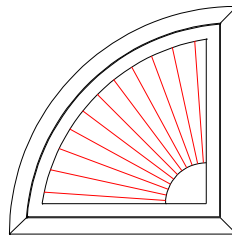

Right Quarter Round Sunburst

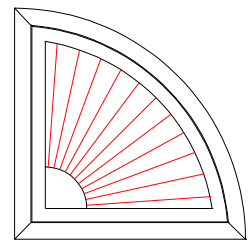

Circle Sunburst

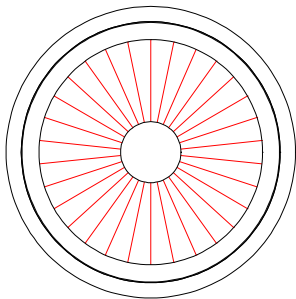

Circle with Horizontal Louvers

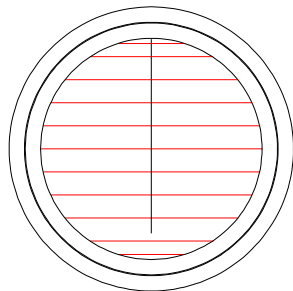

Oval with Horizontal Louvers

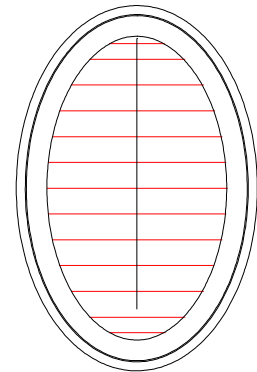

Oval Sunburst

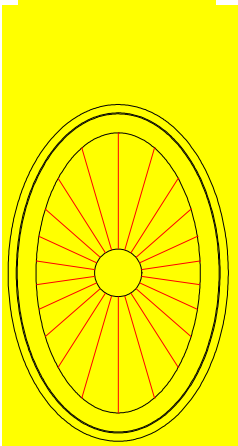

Sunburst on Top with T Post

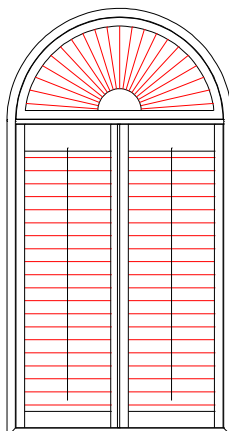

Sunburst on Top with Divider Strip

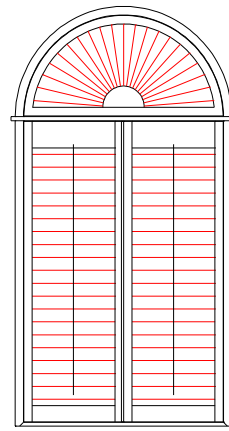

Sunburst on Top with Continuous Frame

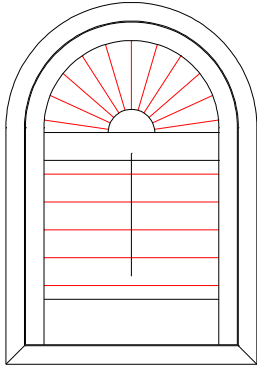

Quarter Sunburst Panel with Continuous Frame

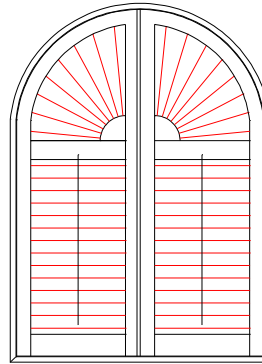

Hexagon Sunburst

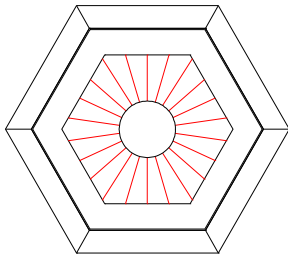

Hexagon Sunburst with Straight Sides

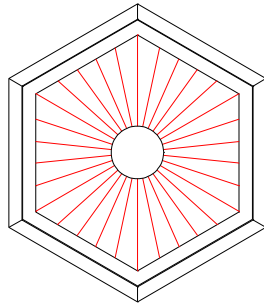

Hexagon with Horizontal Louvers

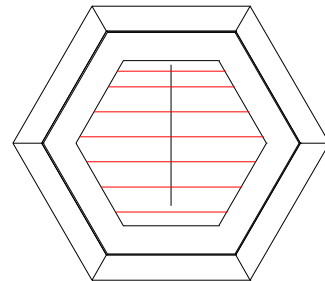

Hexagon Straight Sides with Horizontal Louvers

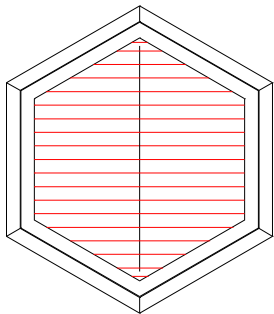

Octagon Sunburst

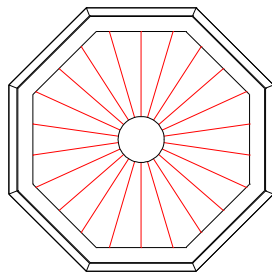

Octagon with Horizontal Louvers

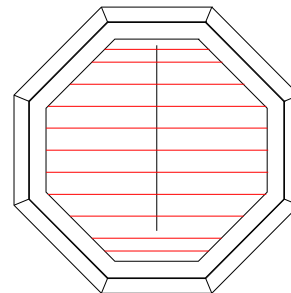



Left Angle Top with Center Tilt Rod /  
Left Rake with Center Tilt Rod

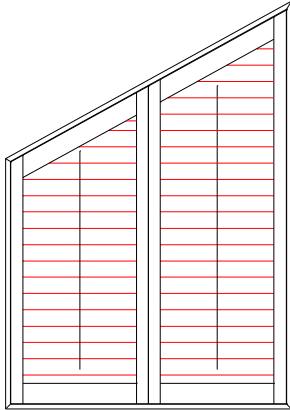

Right Angle Top with Center Tilt Rod /  
Right Rake with Center Tilt Rod

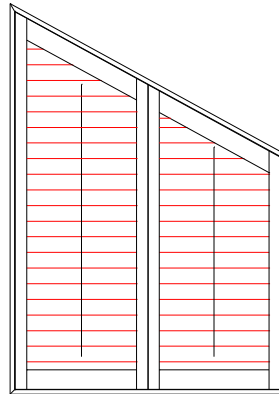

Left Angle Top with Offset Tilt Rod /  
Left Rake with Offset Tilt Rod

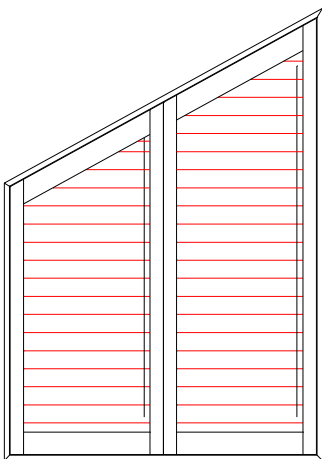

Right Angle Top with Offset Tilt Rod /  
Right Rake with Offset Tilt Rod

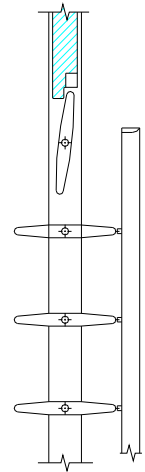
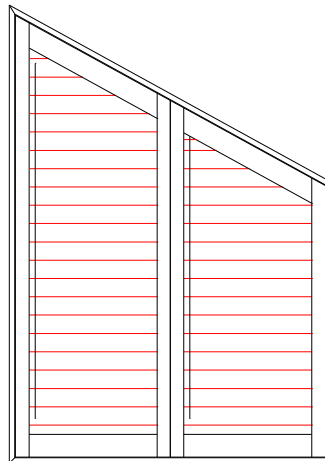

\*Top louver of angle top might  
be fixed as shown above

Triangle with Horizontal Louvers    Triangle Sunburst

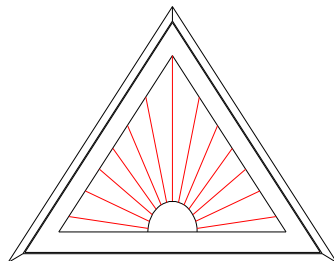
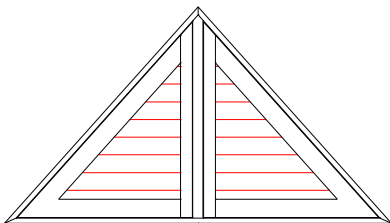

Left Triangle

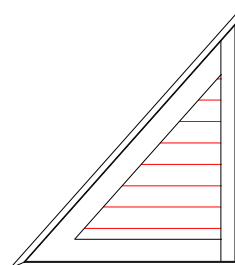

Right Triangle

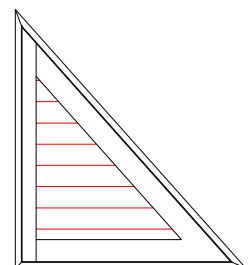

Peak

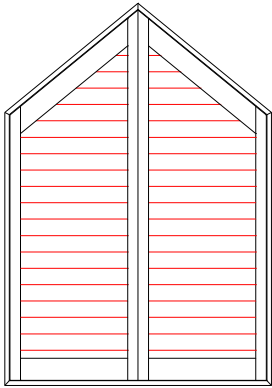

Left Quarter Arch

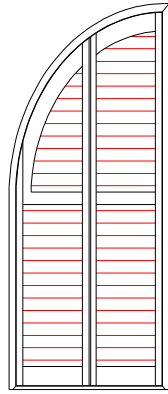

Right Quarter Arch

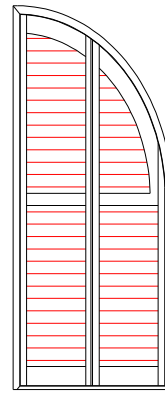

Louvered Arch Shutter with Center Tilt Rod  
-Standard Louvered Arch

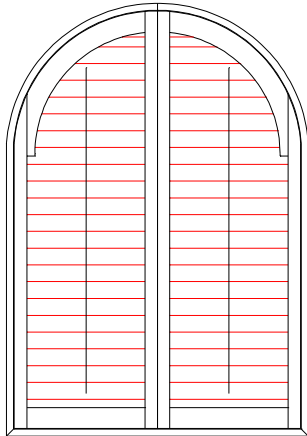

Louvered Arch Shutter with Offset Tilt Rod  
-Standard Louvered Arch

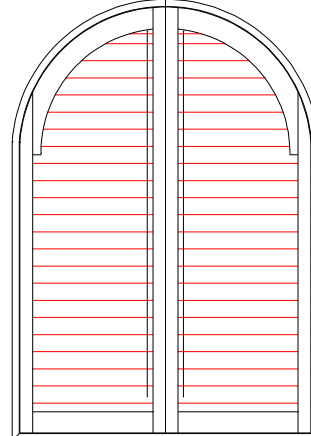

Louvered Arch Shutter with Center Tilt Rod  
-Continuous Arch

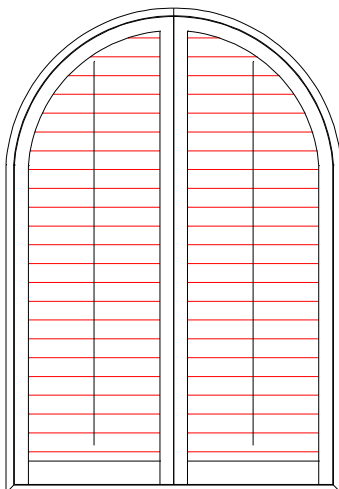

Louvered Arch Shutter with Offset Tilt Rod  
-Continuous Arch

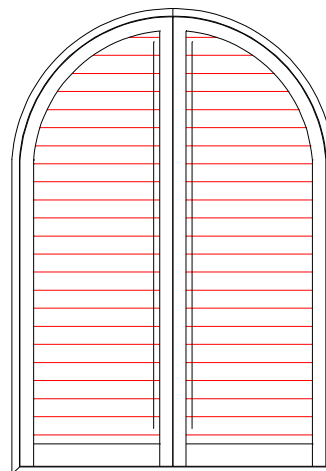

Arch Top Picture Window with Sunburst

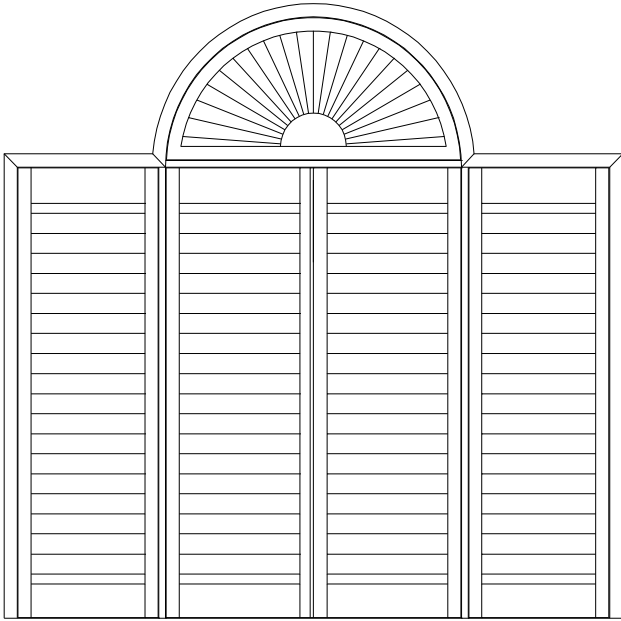

Standard unit with horizontal arch center

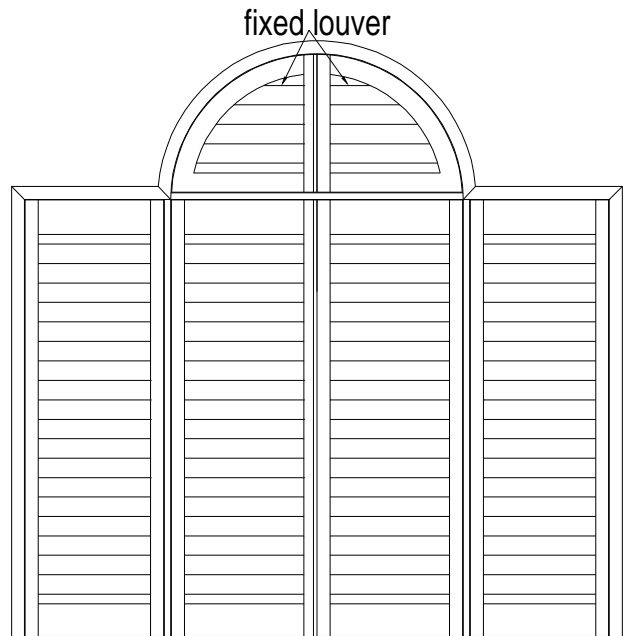

Arch Top Picture Window with horizontal louvers-Standard louvered arch

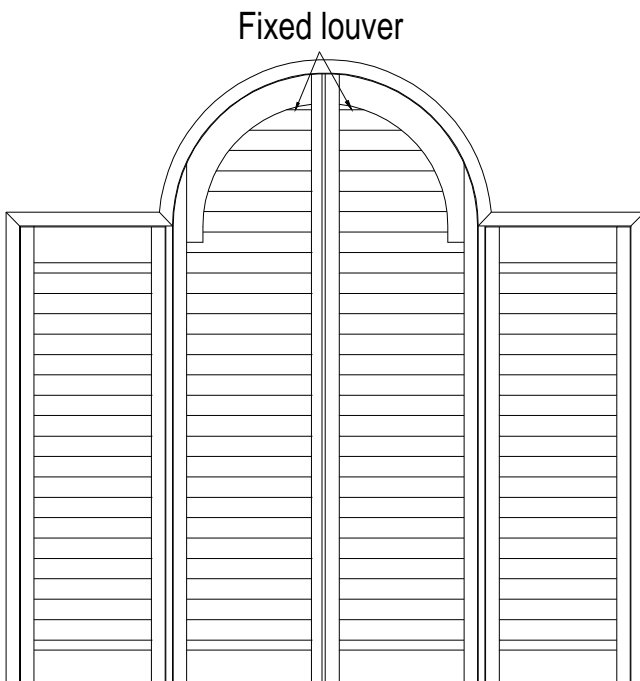

Arch Top Picture Window with horizontal louvers-Continuous arch

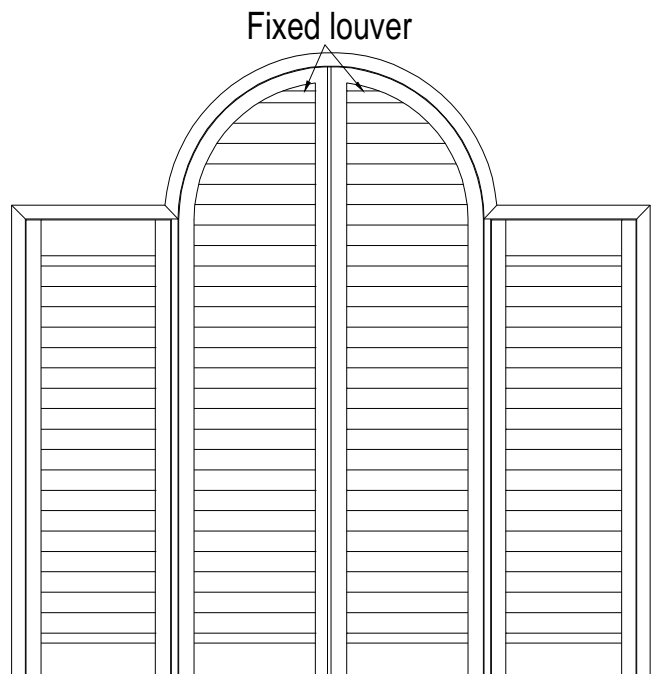

Horizontal louvers center arch with quarter round side panels -Standard louvered arch

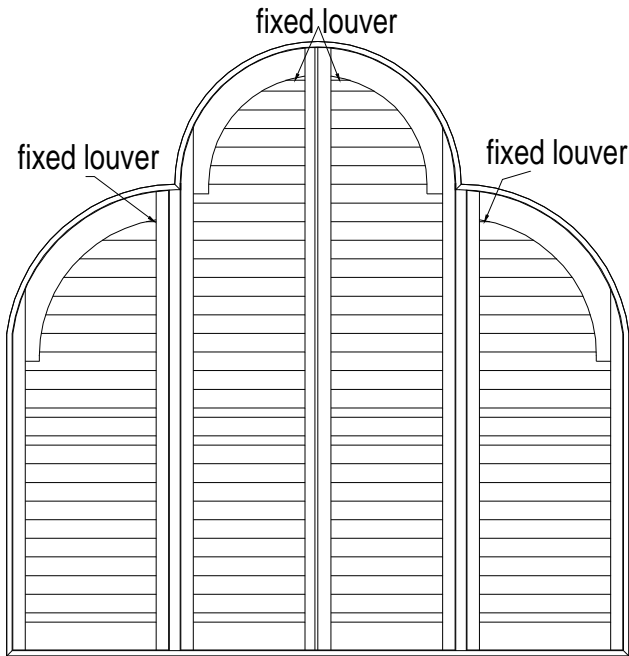

Horizontal louvers center arch with quarter round side panels -Continuous arch

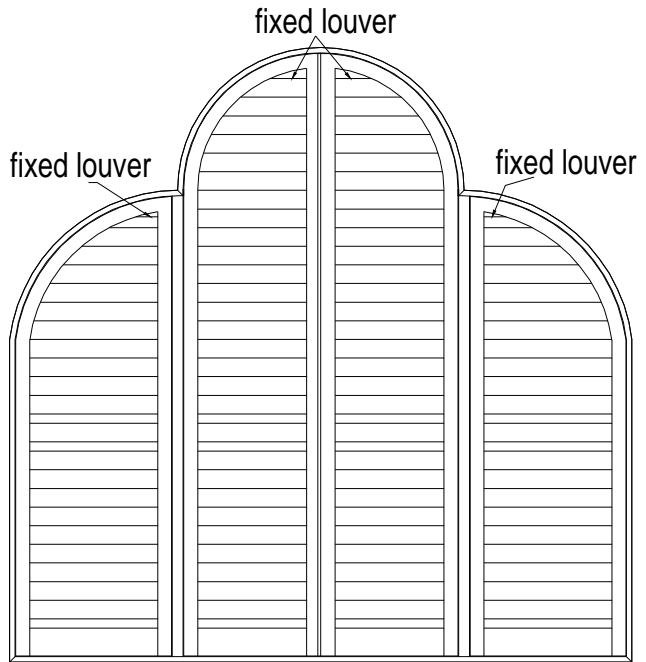

Sunburst louvers center arch with quarter round side panels

Solid Rail Arch

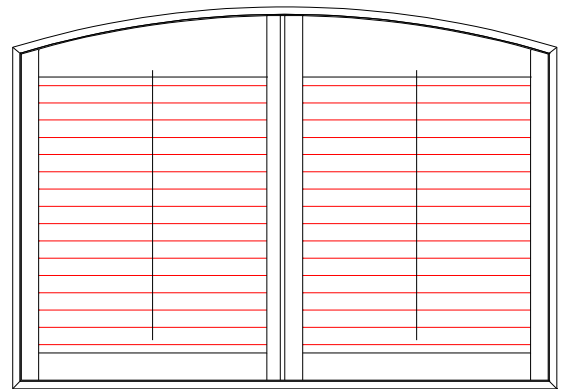
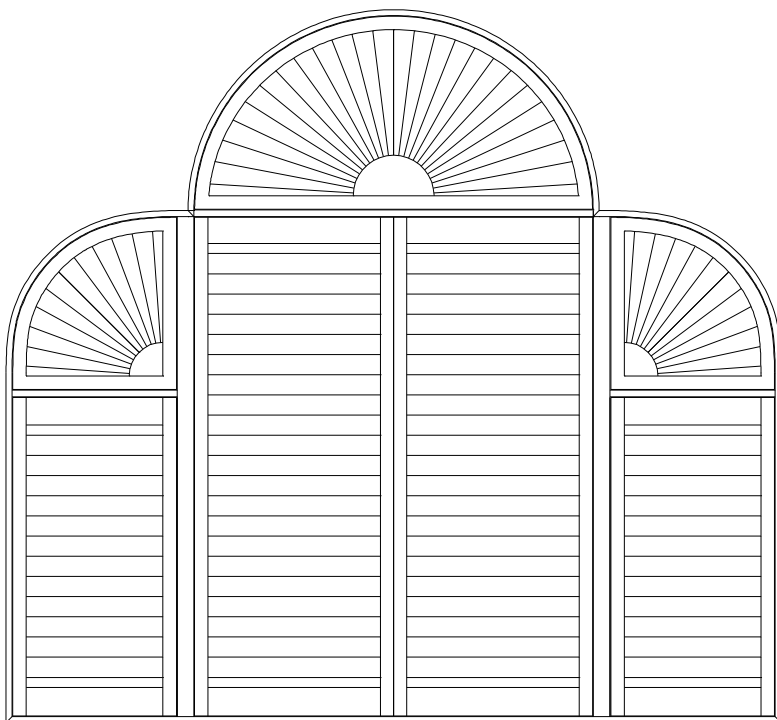

## Solid Rail Arch

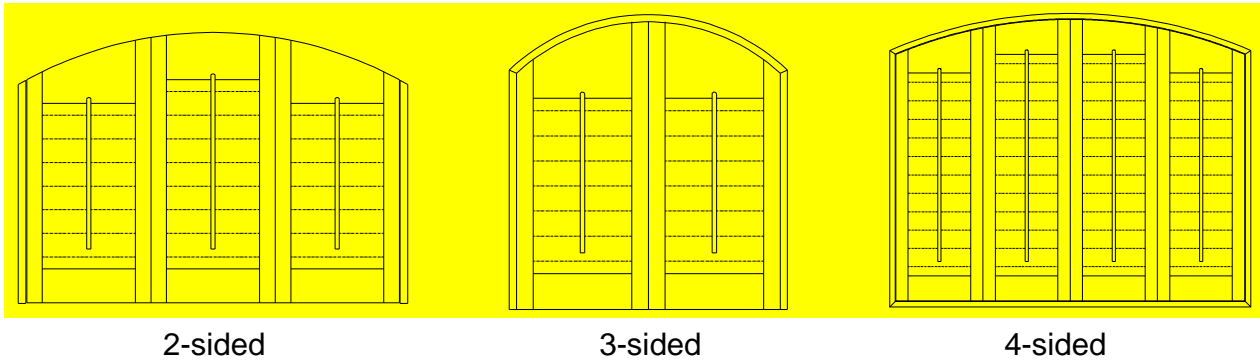

### 1) Solid Rail Arch is available in

- L frames
- Z frames
- Deco frames
- Hang strips

2) Max rail height of the Solid Rail Arch is 6" or less from the leg height as shown in the diagram below.

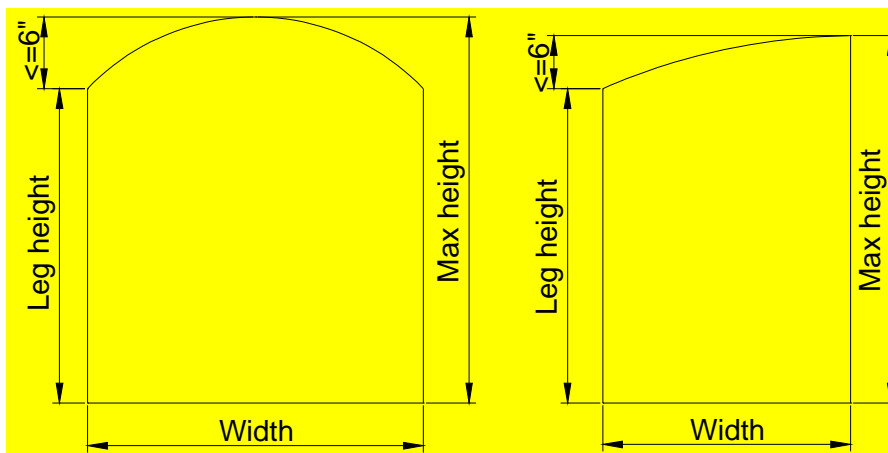

## Template Requirement Guideline

You are required to submit a template if the specialty shutter is:

- An **inside mount**.
- An **imperfect arch**.
- Going to be mounted on **existing molding**.
- An **oval shape**.

An arch is perfect when same radius with same center point pass through all points on arch.

Any specialty arch shutter order without a template will be made as a perfect arch.

If your arch window is imperfect, send us a template.

\*Some surcharges apply

BW I- 10 /

## Pricing

<b>1) By Max Frame-to-Frame Measurement:</b>							
<b>Regular Shutter</b>							
Inside and Outside Mount	Width	x	Height	/ 144	x	\$/sq ft	
<b>Track Shutter**</b>							
Inside	Width	x	Height	/ 144	x	\$/sq ft	
Semi-Inside and Outside Mount	Width	x	(Height-1½")	/ 144	x	\$/sq ft	
<b>2) By Net Panel Measurement:</b>							
	Width	x	Height	/ 144	x	\$/sq ft	
<b>3) By Window Size:</b>							
<b>2" Camber Deco Frame 2" Classic Deco Frame</b>	4-sided	(Width+4")	x	(Height+4")	/ 144	x	\$/sq ft
	3-sided with Sill Plate	(Width+4")	x	(Height+4")	/ 144	x	\$/sq ft
	3-sided	(Width+4")	x	(Height+2")	/ 144	x	\$/sq ft
	2-sided with Sill Plate	(Width+4")	x	(Height+2")	/ 144	x	\$/sq ft
	2-sided	(Width+4")	x	(Height)	/ 144	x	\$/sq ft
<b>3" Ridge Deco Frame</b>	4-sided	(Width+6")	x	(Height+6")	/ 144	x	\$/sq ft
	3-sided with Sill Plate	(Width+6")	x	(Height+6")	/ 144	x	\$/sq ft
	3-sided	(Width+6")	x	(Height+3")	/ 144	x	\$/sq ft
	2-sided with Sill Plate	(Width+6")	x	(Height+3")	/ 144	x	\$/sq ft
	2-sided	(Width+6")	x	(Height)	/ 144	x	\$/sq ft
<b>2.5" Mission deco frame</b>	4-sided	(Width+5")	x	(Height+5")	/ 144	x	\$/sq ft
	3-sided	(Width+5")	x	(Height+2.5")	/ 144	x	\$/sq ft
	2-sided	(Width+5")	x	(Height)	/ 144	x	\$/sq ft
<b>3" Crown Z Frame</b>	4-sided	(Width+4 ½")	x	(Height+4½")	/ 144	x	\$/sq ft
	3-sided with Sill Plate	(Width+4 ½")	x	(Height+4½")	/ 144	x	\$/sq ft
	3-sided	(Width+4 ½")	x	(Height+2¼")	/ 144	x	\$/sq ft
	2-sided with Sill Plate	(Width+4 ½")	x	(Height+2¼")	/ 144	x	\$/sq ft
	2-sided	(Width+4 ½")	x	(Height)	/ 144	x	\$/sq ft

## Pricing

<b>2" Bel Air Z Frame 2" Bullnose Z Frame</b>	4-sided	(Width+2 ½")	x	(Height+2½")	/ 144	x	\$/sq ft
	3-sided with Sill Plate	(Width+2 ½")	x	(Height+2½")	/ 144	x	\$/sq ft
	3-sided	(Width+2 ½")	x	(Height+1¼")	/ 144	x	\$/sq ft
	2-sided with Sill Plate	(Width+2 ½")	x	(Height+1¼")	/ 144	x	\$/sq ft
	2-sided	(Width+2 ½")	x	(Height)	/ 144	x	\$/sq ft
<b>1 1/2" Bullnose Z Frame 1 ¼ " Beaded Z Frame/ Bullnose Tilt Out Z Frame</b>	4-sided	(Width+2")	x	(Height+2")	/ 144	x	\$/sq ft
	3-sided with Sill Plate (N/A w/ Tilt out Z)	(Width+2")	x	(Height+2")	/ 144	x	\$/sq ft
	3-sided	(Width+2")	x	(Height+1")	/ 144	x	\$/sq ft
	2-sided with Sill Plate (N/A w/ Tilt out Z)	(Width+2")	x	(Height+1")	/ 144	x	\$/sq ft
	2-sided	(Width+2")	x	(Height)	/ 144	x	\$/sq ft
<b>Vintage Hang Strip</b>	Inside	Width	x	Height	/ 144	x	\$/sq ft
	Outside 4-sided	(Width+3")	x	(Height+3")	/ 144	x	\$/sq ft
	Outside 3-sided	(Width+3")	x	(Height+1½")	/ 144	x	\$/sq ft
	Outside 2-sided	(Width+3")	x	(Height)	/ 144	x	\$/sq ft
<b>Vintage L Frame/ Beaded L Frame</b>	Outside 4-sided	(Width+3")	x	(Height+3")	/ 144	x	\$/sq ft
	Outside 3-sided	(Width+3")	x	(Height+1½")	/ 144	x	\$/sq ft
	Outside 2-sided	(Width+3")	x	(Height)	/ 144	x	\$/sq ft
<b>Track Shutter**</b>							
Inside and Semi-Inside Mount		Width	x	Height	/144	x	\$/sq ft
Outside Mount		(Width+3")	x	(Height+3")	/144	x	\$/sq ft

1 side frame price:

2" Camber Deco Frame	1-sided	(Width+2")	x	(Height)	/ 144	x	\$/sq ft
2" Classic Deco Frame	1-sided	(Width)	x	(Height+2")	/ 144	x	\$/sq ft
3" Ridge Deco Frame	1-sided	(Width+3")	x	(Height)	/ 144	x	\$/sq ft
	1-sided	(Width)	x	(Height+3")	/ 144	x	\$/sq ft
2 1/2" Mission deco frame	1-sided	(Width+2 1/2")	x	(Height)	/ 144	x	\$/sq ft
	1-sided	(Width)	x	(Height+2 1/2")	/ 144	x	\$/sq ft
3" Crown Z Frame	1-sided	(Width+2 1/4")	x	(Height)	/ 144	x	\$/sq ft
	1-sided	(Width)	x	(Height+2 1/4")	/ 144	x	\$/sq ft
2" Bel Air Z Frame	1-sided	(Width+1 1/4")	x	(Height)	/ 144	x	\$/sq ft
2" Bullnose Z Frame	1-sided	(Width)	x	(Height+1 1/4")	/ 144	x	\$/sq ft
1 1/2" Bullnose Z Frame	1-sided	(Width+1")	x	(Height)	/ 144	x	\$/sq ft
1 1/4" Beaded Z Frame	1-sided	(Width)	x	(Height+1")	/ 144	x	\$/sq ft
Bullnose Tilt Out Z Frame							
Vintage Hang Strip	Outside 1-sided	(Width+1 1/2")	x	(Height)	/ 144	x	\$/sq ft
	Outside 1-sided	(Width)	x	(Height+1 1/2")	/ 144	x	\$/sq ft
Vintage L Frame	Outside 1-sided	(Width+1 1/2")	x	(Height)	/ 144	x	\$/sq ft
Beaded L Frame							
Beaded L with 1/4" Light Block							
Beaded L with 1/2" Buildout	Outside 1-sided	(Width)	x	(Height+1 1/2")	/ 144	x	\$/sq ft
Beaded L with 1" Buildout							
Vintage L with 1/4" Light Block							
Vintage L with 1/2" Buildout							
Vintage L with 1" Buildout							