

Important: Be sure to get familiar with the *Roller Shades - Skyline Fascias installation instructions* before continuing. Make sure the mounting surface is level. Brackets must be in line and level for shade to operate properly. Shim brackets if necessary.

1. Identify the Shade and Define Shades and Bracket Positions

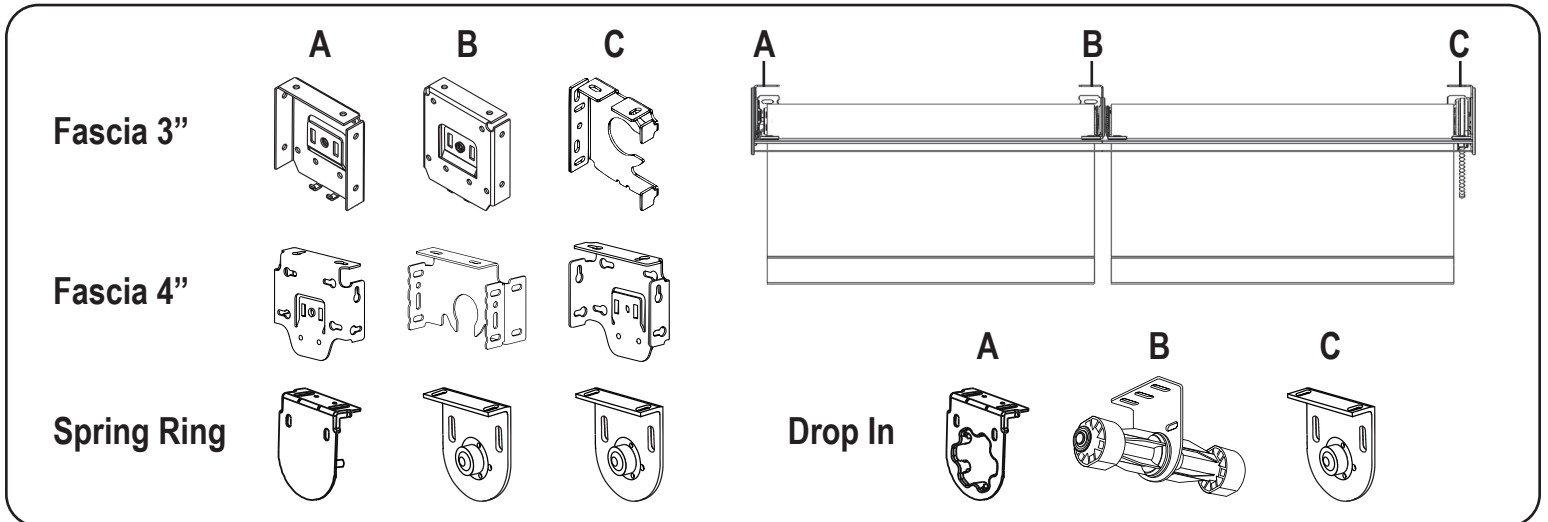

On Fascia 3 and 4" System, the edges brackets (A and C) are the same. On the Spring Ring and Drop in systems, the "A" bracket should be placed on the edge at the motor side. The "C" brackets should be installed at the idle edge. The Intermediate Brackets (B) should be located between shades.

2a. Install the First Shade

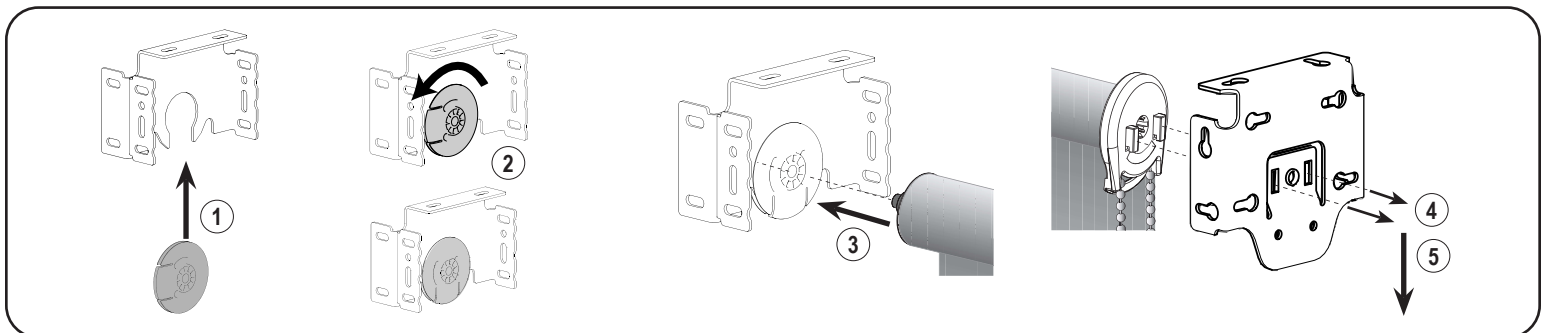

Install the first shade brackets following the same steps as a regular shade (Please refer to *Roller Shades - Skyline Fascias installation instructions*). First, assemble the Intermediate Bracket Disc into the intermediate bracket. **Rotate the disc 1/4 turn** to lock into place. Then, place the spring loaded pin end into the round hole of the intermediate bracket. Keeping the pin end secure in its bracket, insert the hooks straight into the two slots in the outer bracket. Once the two hooks are through the slots, gently pull downward until the two hooks have locked securely to the bracket.

2b. Install the Second Shade

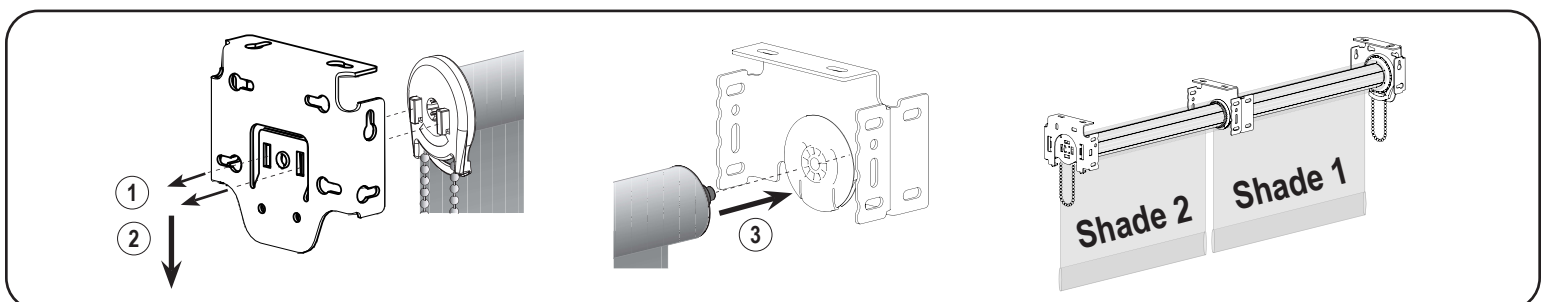

Install the final regular bracket aligned and leveled with the others. Place the spring loaded pin end into the round hole of the intermediate bracket. Keeping the pin end secure in its bracket, insert the hooks on the clutch straight into the two slots in the bracket. Once the two hooks are through the slots, gently pull downward on the side with two hooks until the two hooks have locked securely to the bracket.

INSTALLATION INSTRUCTIONS

3. Install the Fascia

See more detail on *Roller Shades - Skyline Fascias installation instructions*.

4a. Drop In - Install the Motorized Shade

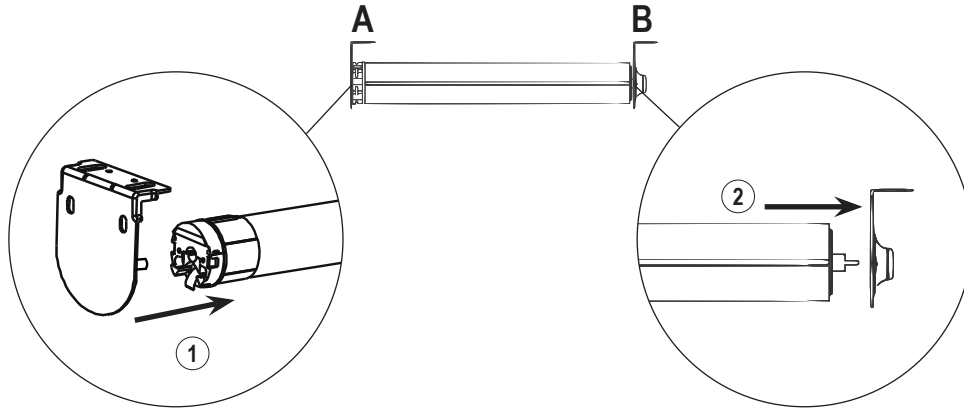

Note: Illustration shown under Open Roll without top treatment, same concept applies to Fascia & Pocket.

Install the shade with the motor brackets (A and B) following the steps in the provided *Roller Shades Installation Instructions*.

Important: The intermediate bracket foot must point away from the motor bracket.

4b. Drop In - Install the Second Shade

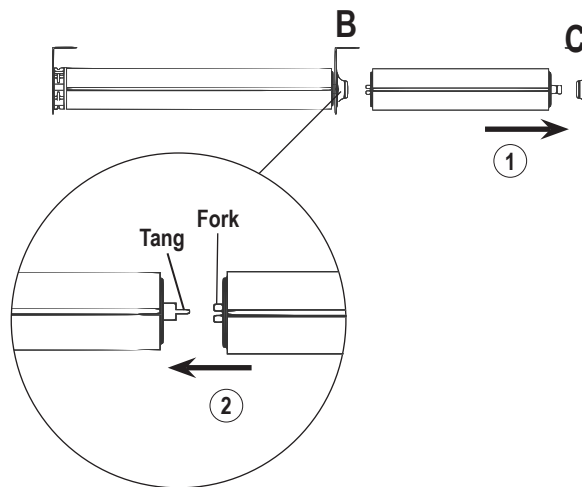

Note: Illustration shown under Open Roll without top treatment, same concept applies to Fascia & Pocket.

Install the final bracket (C) level and aligned to the other brackets, following the steps in the provided *Roller Shades Installation Instructions*.

Place the spring loaded pin end into the round hole of the bracket (C). Keeping the pin end secure in its bracket, insert the fork side of the shade to the bronze bushing. While holding the motor side shade to make sure it does not come loose, lock the fork from the idler side shade into the tang at the intermediate bracket (B).

INSTALLATION INSTRUCTIONS

5a. Spring Ring - Install the Motorized Shade

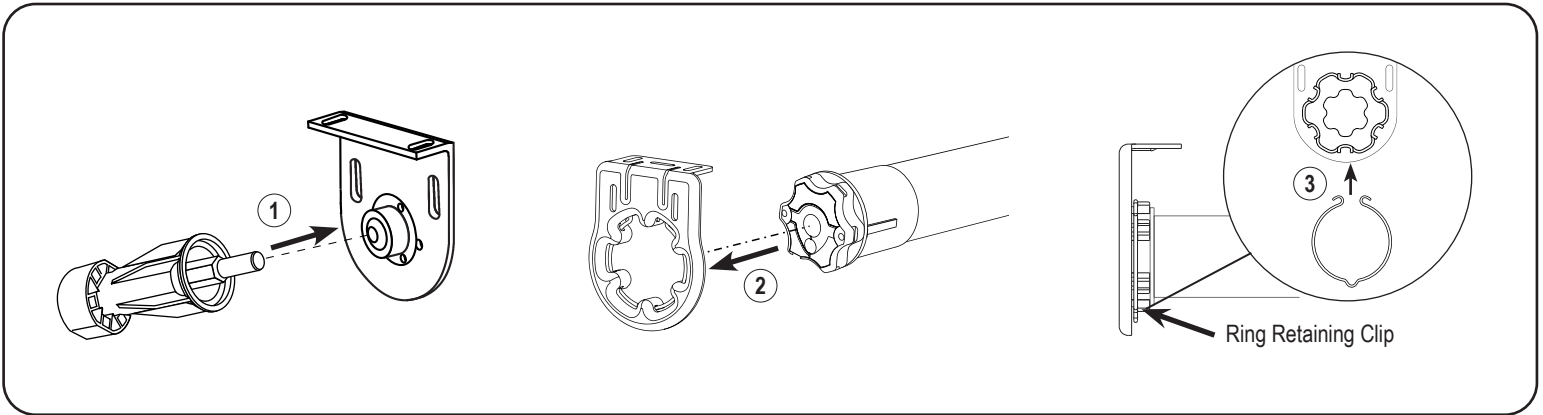

Note: Illustration shown under Open Roll without top treatment, same concept applies to Fascia & Pocket.

Install the shade with the motor brackets (A and B) following the steps in the provided *Roller Shades Installation Instructions*.

Once the brackets are installed, rotate the roll to ensure reset button of the motor is facing down. Place the spring loaded pin end into the round hole of the Idler bracket. Then, keeping the pin end secure in its bracket, align and insert the motor head into the slots in the motor bracket. Lastly, once the motor is completely secured into the motor bracket, snap the ring retaining clip in place, locking the motor in position.

5b. Spring Ring - Install the Second Shade

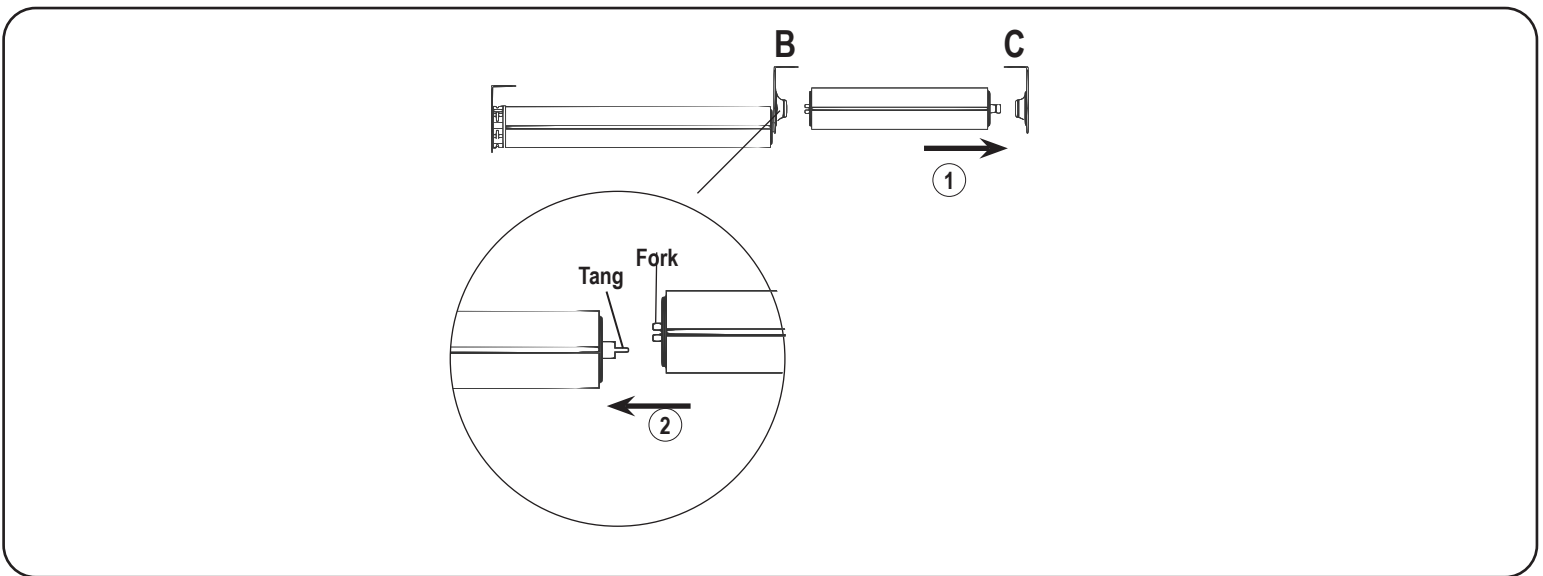

Note: Illustration shown under Open Roll without top treatment, same concept applies to Fascia & Pocket.

Install the final bracket (C) level and aligned to the other brackets, following the steps in the provided *Roller Shades Installation Instructions*.

Place the spring loaded pin end into the round hole of the bracket (C). Keeping the pin end secure in its bracket, insert the fork side of the shade to the bronze bushing. While holding the motor side shade to make sure it does not come loose, lock the fork from the idler side shade into the tang at the intermediate bracket (B).

INSTALLATION INSTRUCTIONS

6a . Removing the Shade (Only If Necessary) — Removing the Fascia

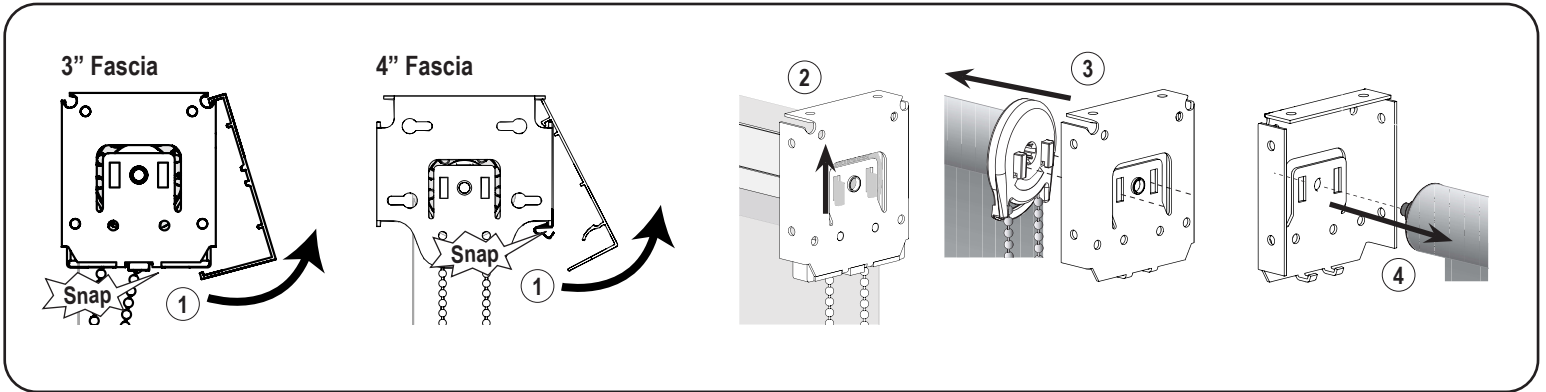

First, rotate upward to disengage the fascia. Then, gently pull up the control unit (Clutch, Motor or Spring) until the hooks touch the top part of the bracket slot. Pull the shade towards the spring loaded pin end until the hooks are complete out of the bracket slots. Finally, remove the spring loaded pin end from the idler bracket.

6b. Removing the Shade (Only if Necessary — Spring Ring)

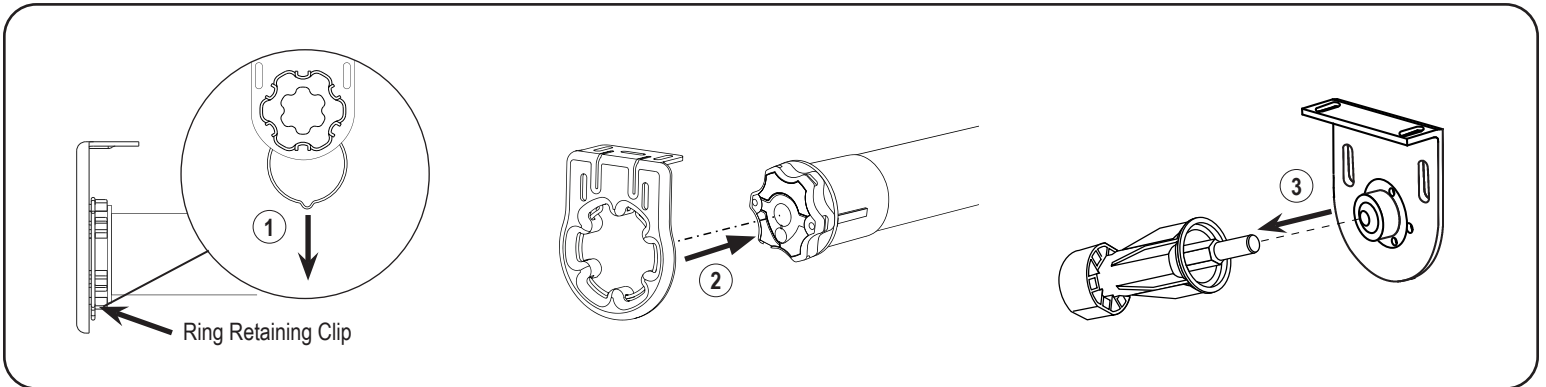

Note: Illustration shown under Open Roll without top treatment, same concept applies to Fascia & Pocket.

First, raise the shade. Remove the ring retaining clip in place from the motor. Then, slide the roll towards the spring loaded pin end until the motor head are completely out of the motor head slots. Lastly, remove the spring loaded pin end from the Idler bracket.

