

## POCKET INSTALLATION BEST PRACTICES

### SCREW MOUNTING POSITIONS

Rollease Acmeda recommends the following best practices when installing commercial recessed Pockets:

- Always install screws through top of Pocket
- Use #8 Anodized self-tapping screws when possible
- When making field alterations, use a saw blade designed to cut metal.

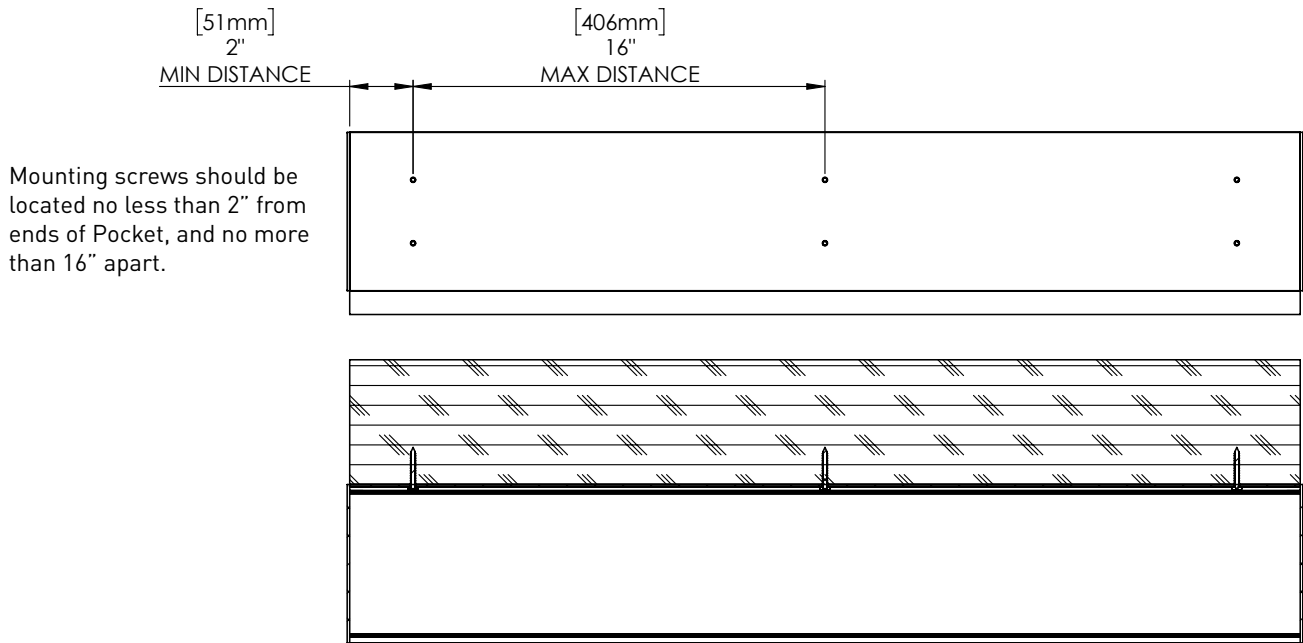

### INSTALLATION

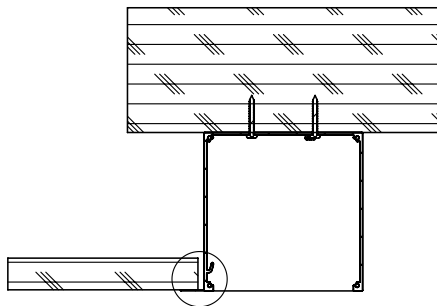

Always make sure that mounting screws are securely tightened into the blocking or material that the Pocket is being mounted to.

Always install screws through top of Pocket  
Use #8 Anodized self-tapping screws when possible

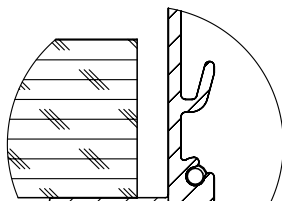

Use the tile lip to hide rough finishes.

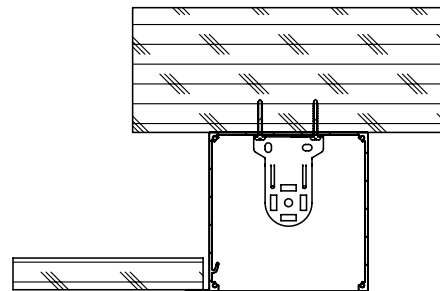

Do not mount shade brackets to endplates. Install brackets into blocking or building material directly.

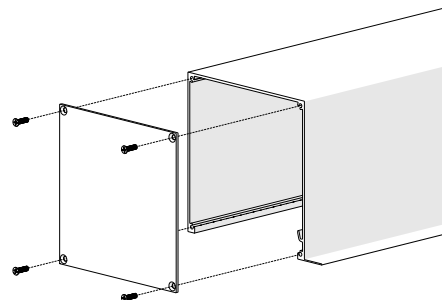

Install endplates using #6 flathead screw.  
RA Catalogue #: RCEPS100xx

## FIELD ALTERATIONS

### CUTTING POCKET TO SIZE

- Pockets can be cut to size while on-site.
- Use a saw blade specified for cutting metal.

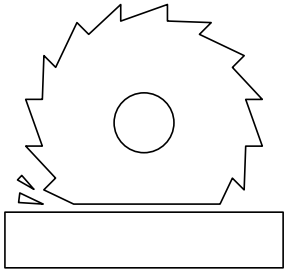

### DIVERTERS

Use proper diverter to ensure cord/chain can exit pocket and closure without getting caught on the closure panel.

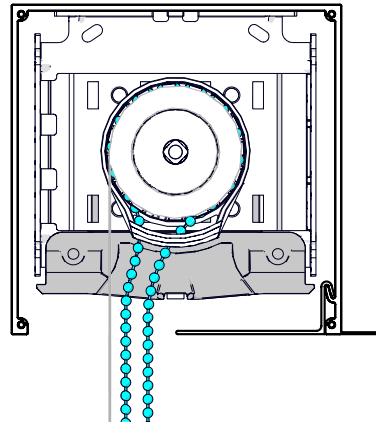

### MAKING A CORNER

- To create a seamless corner, cut end at 45°.
- On second pocket piece, cut end at 45° opposite first cut.
- Abut the two pieces to match the corner.

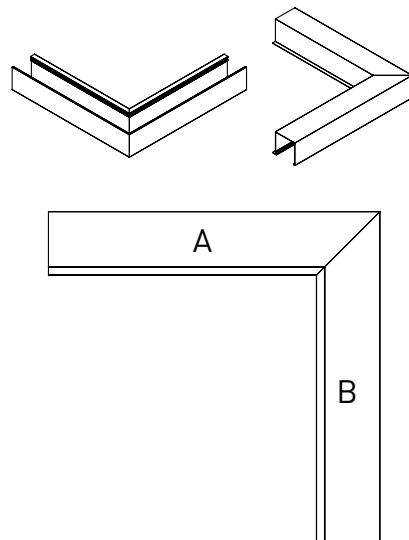
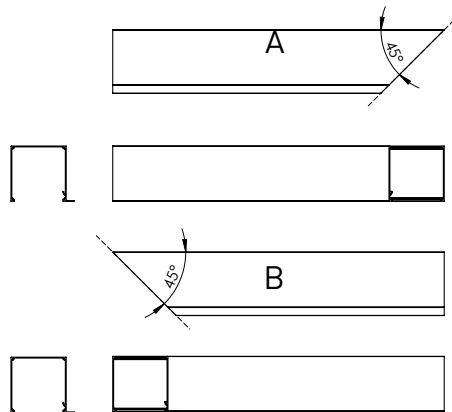

### NOTCHING THE CLOSURE PANEL

If the shade system's clutch hangs below the closure panel, use snips to notch the end of the closure panel at the clutch.

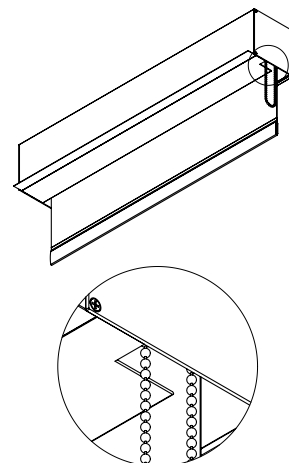
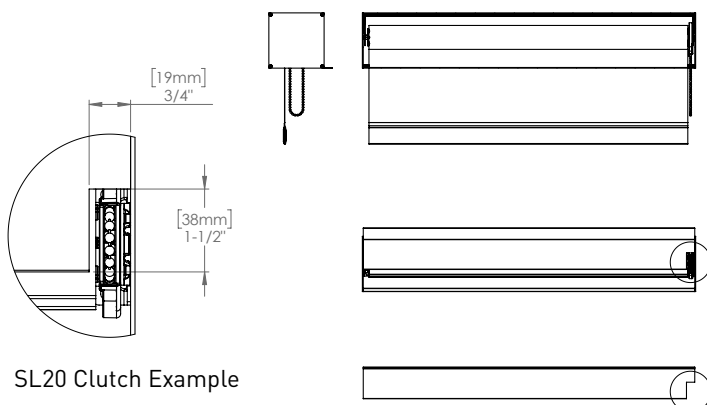

ROLLEASE ACMEDA  
USA

750 East Main Street, 7th Floor  
Stanford, CT 06902

T +1 203 964 0513 | F +1 800 552 5100

---

[contract@rolleasacmeda.com](mailto:contract@rolleasacmeda.com)

[rolleasacmedacontract.com](http://rolleasacmedacontract.com)

---