

Triathlon Roman Shade Fabrication Kit

Serena Roman Shade Fabrication Kit

The Lutron Triathlon/Serena Roman Shade Fabrication Kit is a battery-powered, versatile motorization solution for custom-fabricated Roman shades. This motorization solution works with most Roman shade constructions and materials, controls the movement of the shade, keeps track of the shade's position, and adjusts the shade to the user's desired preset positions while moving smoothly.

Features

- Support for most Roman shade styles and lift mechanisms
- Lift rings are designed to attach lift cords/tapes to the tube (lift mechanism not provided by Lutron). *
- Supports single shades in:
 - Widths from 20 in (508 mm) to 109.5 in (2.78 m)
 - Heights from 12 in (304.8 mm) to 120 in (3.05 m)
 - Maximum lift capacity: 11.7 lb (5.3 kg)**
- Industry-leading battery performance (battery life details are available in the shade ordering tool)
- The Electronic Drive Unit (EDU) maintains consistent shade speed throughout the battery life cycle by dynamically monitoring battery voltage output
- Integrated wireless control using Clear Connect Type A RF technology
- Wireless control range: 30 ft (9 m)
- Operating voltage: 6.0–12.0 V $\overline{=}$
- Shades can be grouped to move together in unison
- Sound: 38 dBA measured 3 ft (0.91 m) from the EDU
- Shade drive facilitates shade movement at 3.6 in/second

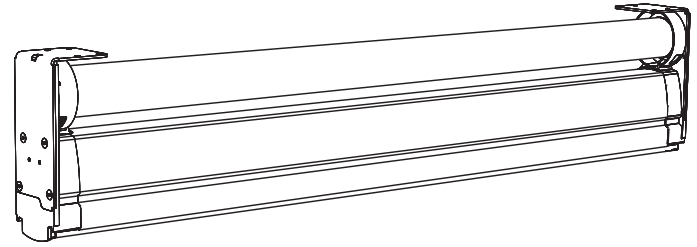

Compatible Controls

- Triathlon models
 - Pico wireless control
 - 4-Group RF shade remote control
 - Caséta (Smart Hub PRO)
 - RA2 Select
 - RadioRA 3
 - HomeWorks systems with QSX processors
- Serena models
 - Pico wireless control
 - 4-Group RF shade remote control
 - Caséta
 - Caséta (Smart Hub PRO)

Environment

- Temperature: 32 °F to 104 °F (0 °C to 40 °C)
- For indoor use only
- Relative humidity: <90% non-condensing

Regulatory

- cULus listed (E135084)
- FCC (USA)

NOTES:

- * Use lift rings for shades up to 80 in (2032 mm) wide. For shades wider than 80 in (2032 mm), use Roman Shade C-Clips from others that are compatible with 1.5 in (38 mm) shade tubes, or other appropriate lift mechanism attachments.
- ** Maximum lift capacity depends on shade configuration and dimensions. Refer to the ordering tool for Maximum lift capacity. The kit is suitable for direct lift only. Indirect lift is not recommended. Refer to page 2 for more details.

▲ IMPORTANT SAFETY NOTICE:

Window shades and blinds are subject to industry standards and government regulations intended to enhance safety and to protect children against risk of strangulation from entanglement in cords or bands. Among other things, these standards and regulations govern the treatment of accessible cords or bands, warning labels and hang tags, and the spacing of pleats in finished shades and blinds.

You are responsible for ensuring that your finished window shades or blinds meet all applicable standards and regulations.

Job Name:

Model Numbers:

Job Number:

System Overview

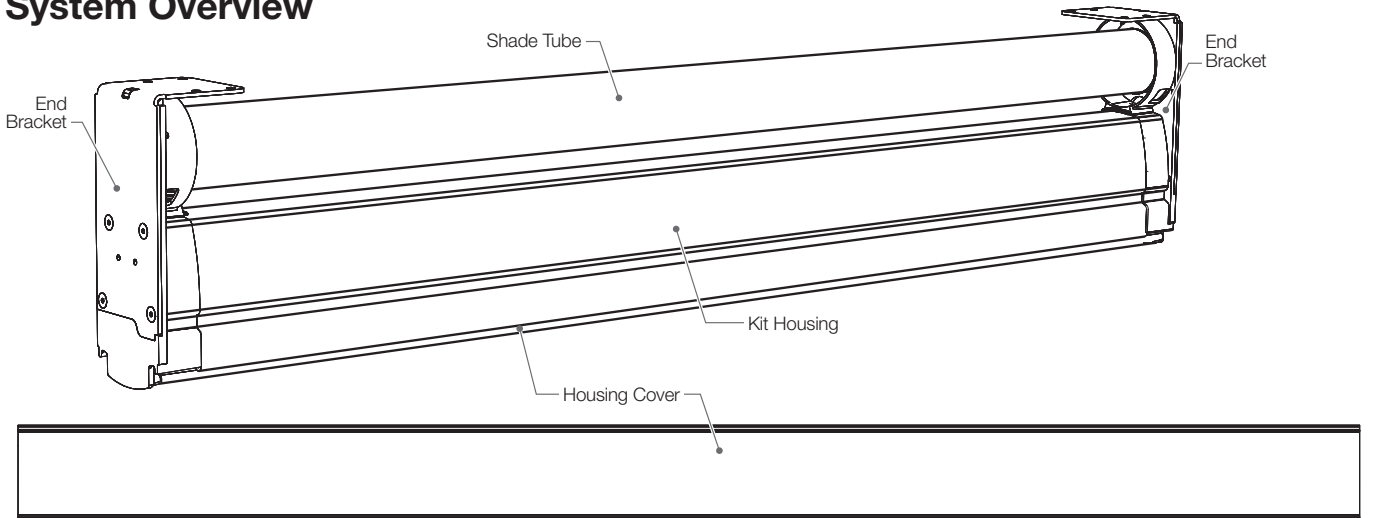

Internal Components (cover removed)

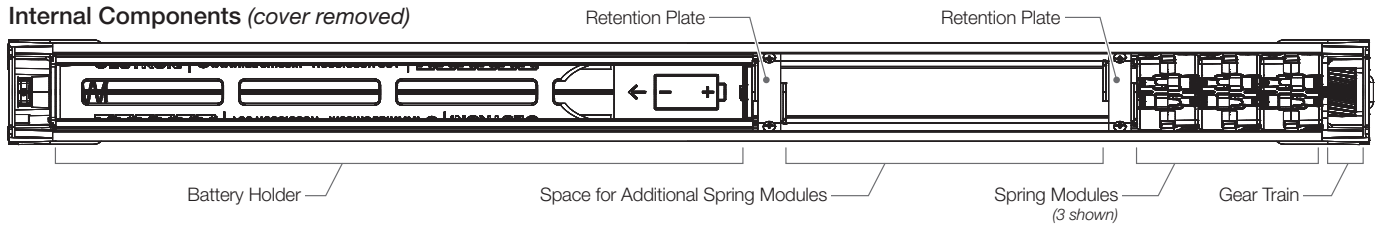

Lift Rings 5-Pack with Screws
WIN-RM-SMRNG-5PK
(available to be shipped with the kit or separately)

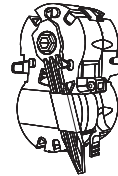

Spring Module
WIN-BRM-SPRG
(one pre-installed, additional spring modules can be ordered with the shade or separately)



System Lock
WIN-BRM-LOCK
(one pre-installed, also available separately)

Direct Lift Only

- The lift cords must be routed directly onto, and over, the tube ('direct lift').
- Do not route lift cords under the tube.
- Due to a decreased lift capacity, indirect lift is not recommended.

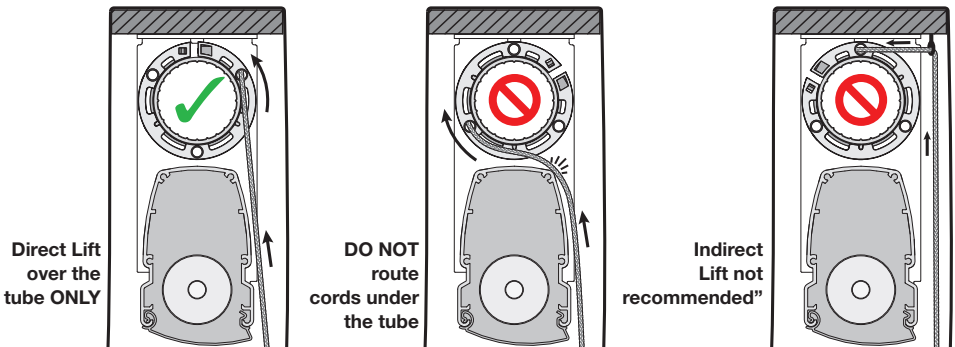

Job Name:	Model Numbers:
Job Number:	

Dimensions

Back-Valance Shade

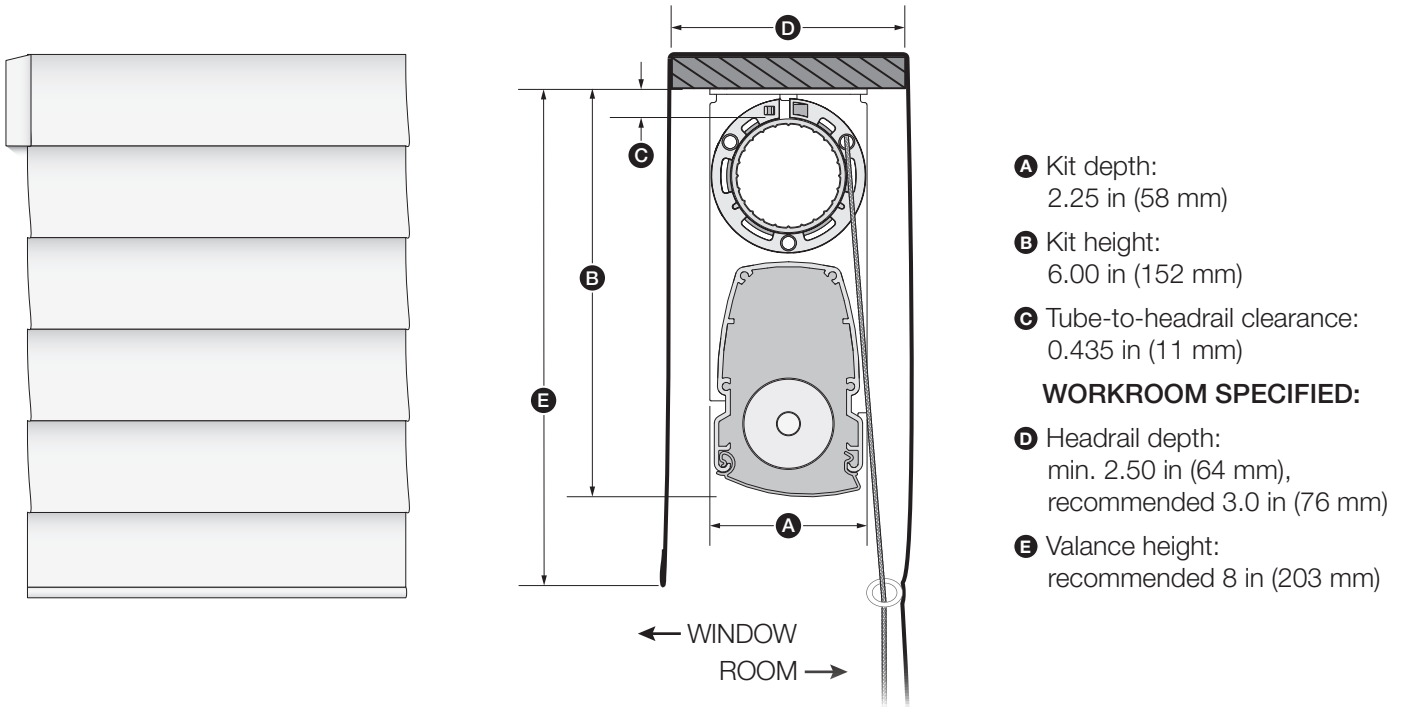

Front-Valance Shade

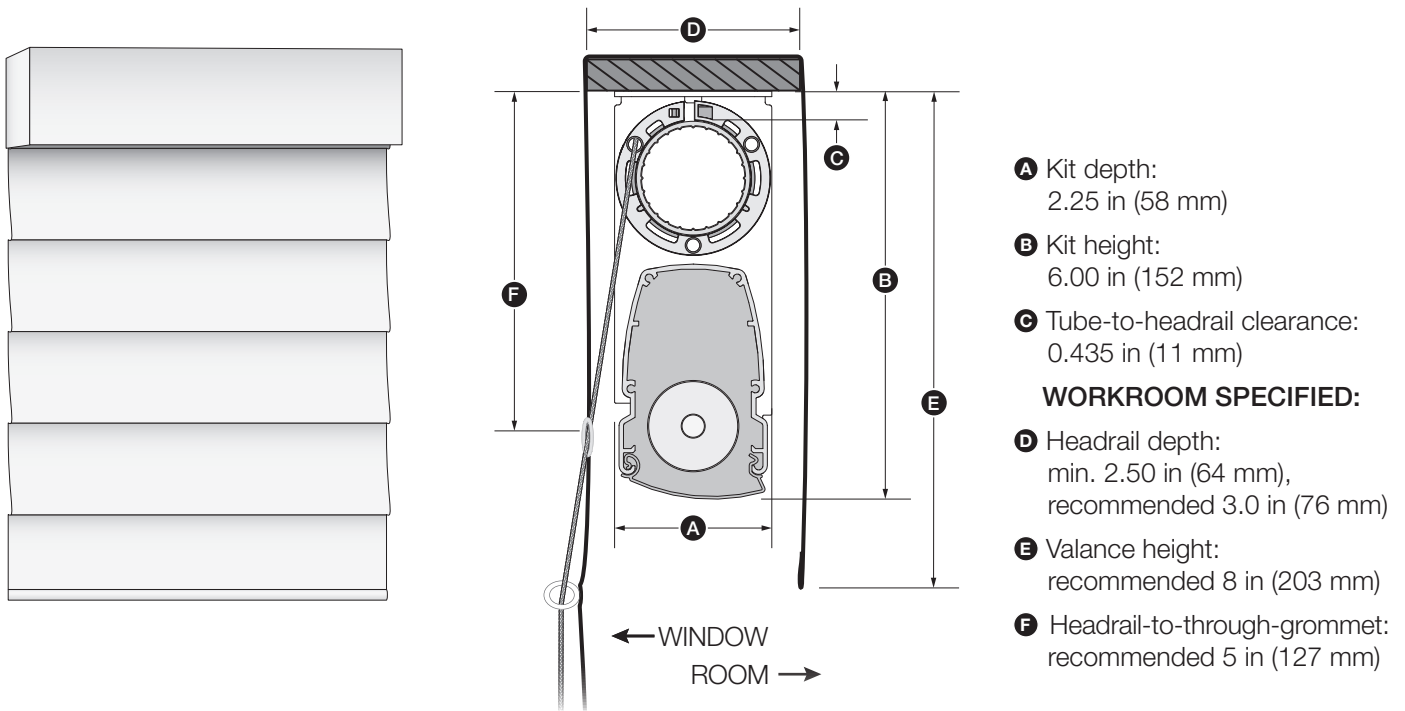

Job Name:	Model Numbers:
Job Number:	

Dimensions (continued)

Fabric Panel and Lift Cord Placement

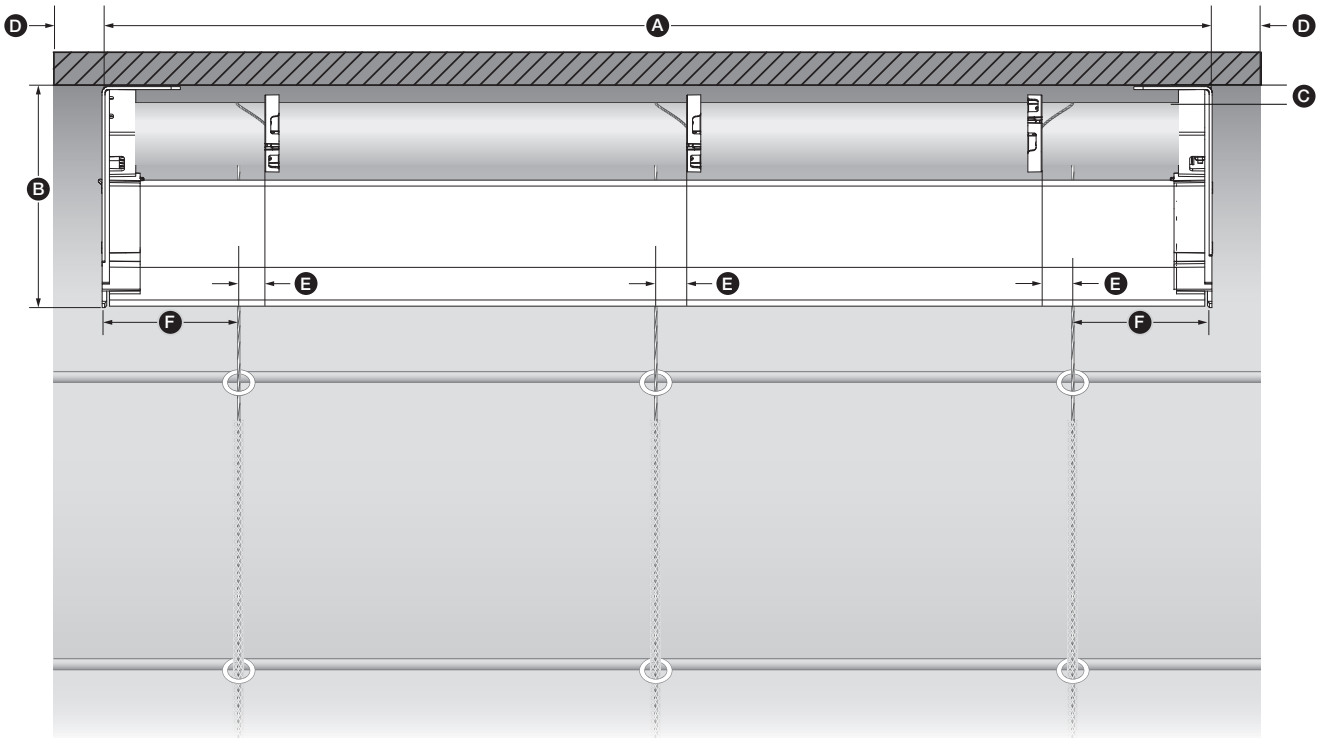

- A** Bracket-to-bracket width; min. 20 in (508 mm); max. 109.5 in (2781 mm)
- B** Kit height: 6.0 in (152 mm)
- C** Tube-to-headrail clearance: 0.553 in (14 mm)

WORKROOM SPECIFIED:

- D** Headrail-to-bracket clearance; min. 1.0 in (25.4 mm) recommended
- E** Cord-route-to-lift-ring offset: min. 1.0 in (25.4 mm) left or right
(0.25 in per 12 in [305 mm] of fabric height recommended)
- F** Bracket-to-first-cord-route distance; min. 1.5 in (38 mm)

Job Name:	Model Numbers:
Job Number:	

Kit Configuration and Assembly

Attach the Kit to the Board

Fasten the kit (tube-down, as shown), end brackets to the wood board using eight (8) fasteners (4 provided for each bracket) of appropriate type and length for the board material and thickness.

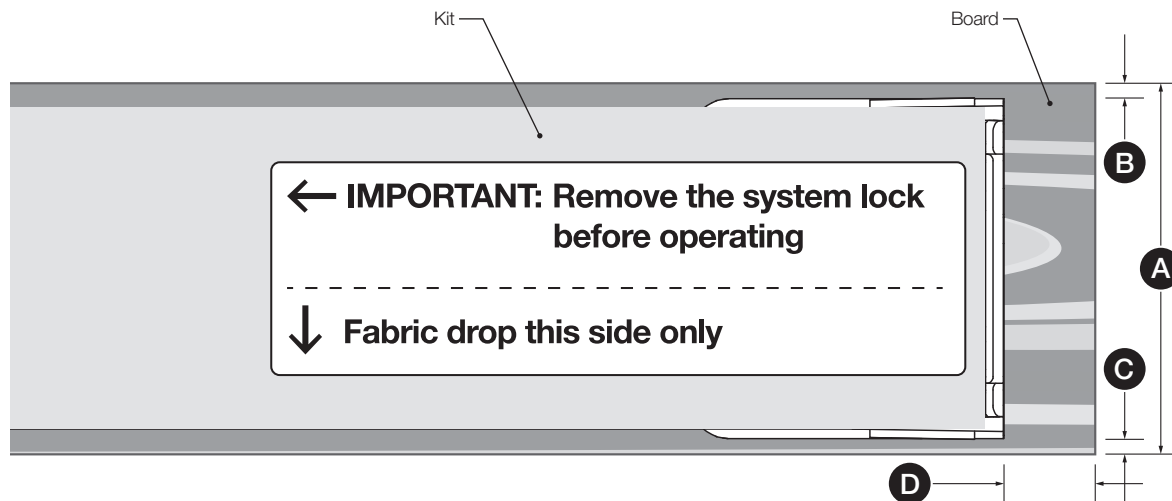
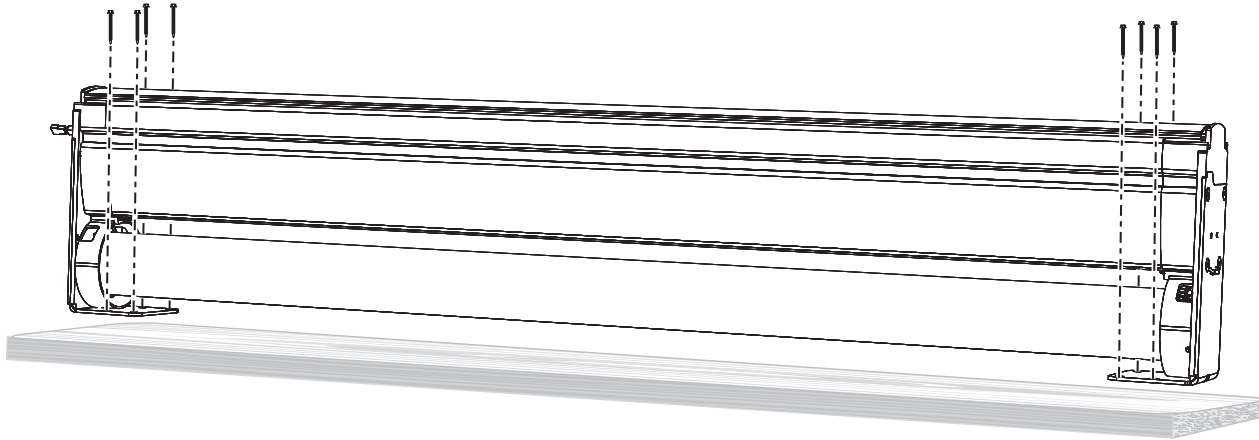

- Ⓐ Board depth: min. 2.50 in (64 mm), recommended 3.0 in (76 mm)
- Ⓑ Kit-to-board-edge (valance side): min. 0.125 in (3 mm)
- Ⓒ Kit-to-board-edge (fabric drop side): max. 0.125 in (3 mm)
- Ⓓ Kit-to-board-end (both ends): min. 1.0 in (25.4 mm)

Job Name:

Model Numbers:

Job Number:

Kit Configuration and Assembly *(continued)*

Back-Valance Shade Layout

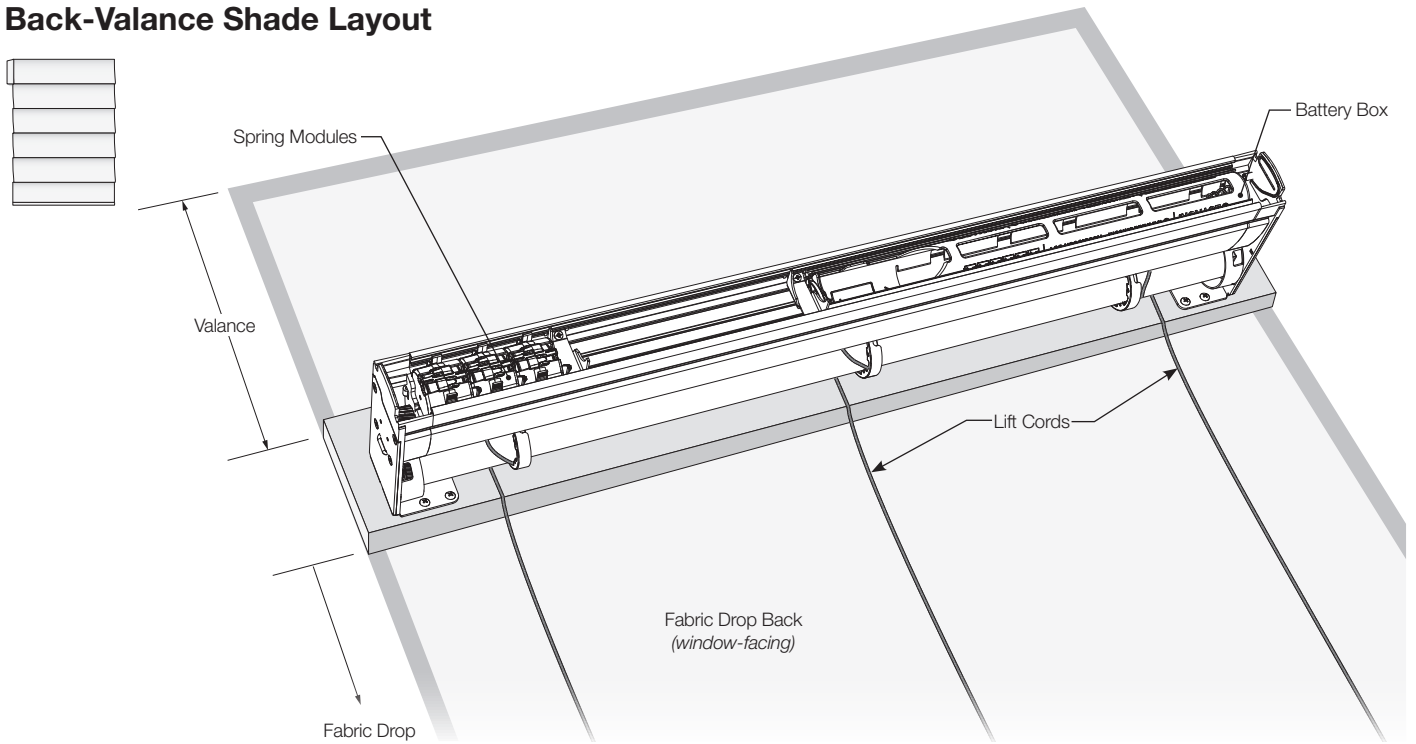

Front-Valance Shade Layout

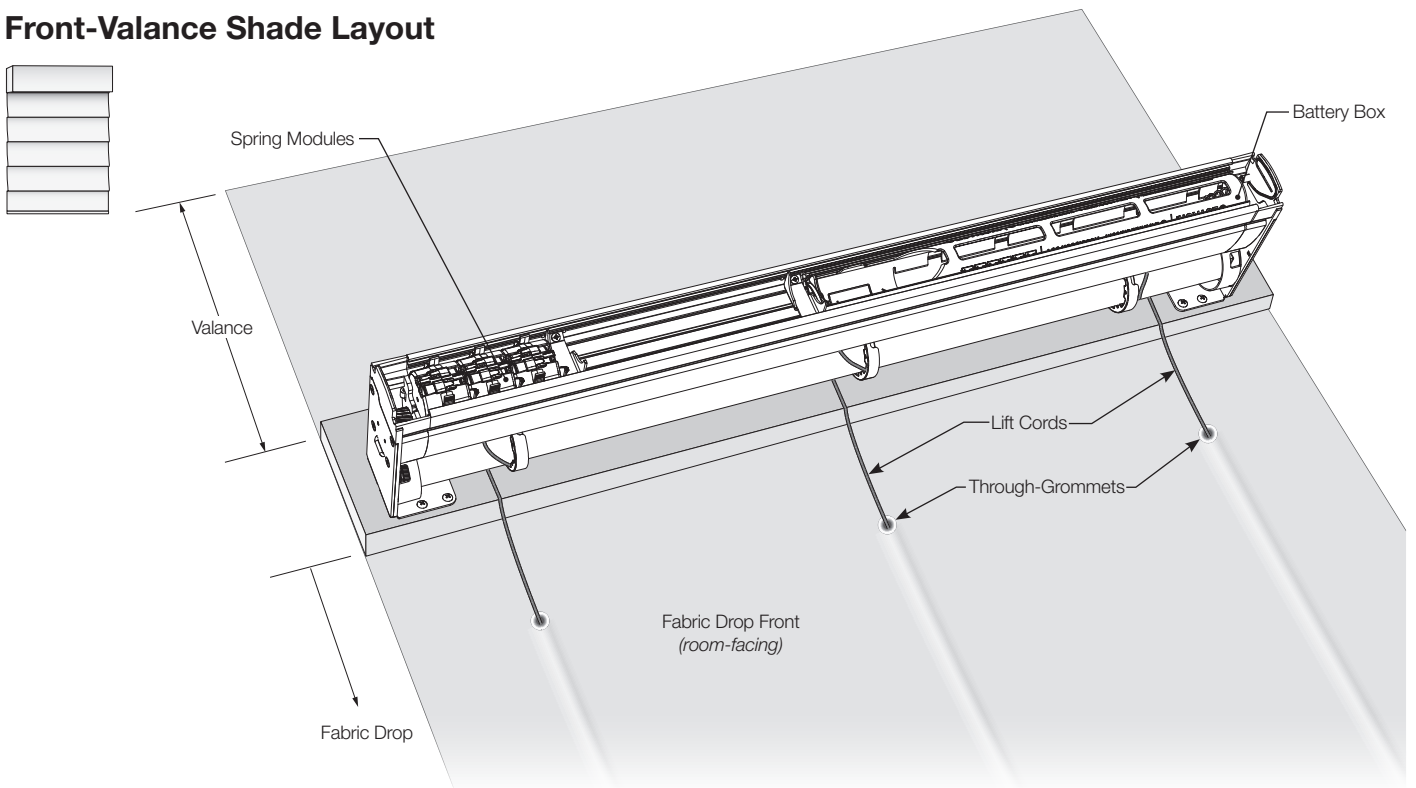

Job Name:	Model Numbers:
Job Number:	

Kit Configuration and Assembly *(continued)*

Lift Cord Attachment

IMPORTANT: Use lift rings for shades up to 80 in (2032 mm) wide. For shades wider than 80 in (2032 mm), use Roman Shade C-Clips from others that are compatible with 1.5 in (38 mm) shade tubes, or other appropriate lift mechanism attachments.

From the front of a Lift Ring, feed the end of a Lift Cord through one of the round holes in the ring, as shown:

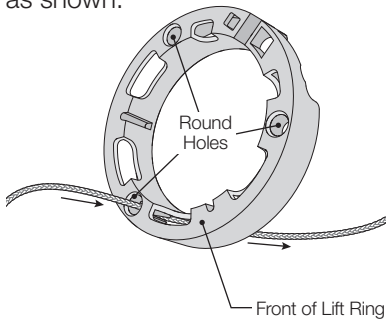

From the back of the Lift Ring, tie a knot in the free end of the Lift Cord (a 'figure-8' knot is recommended).

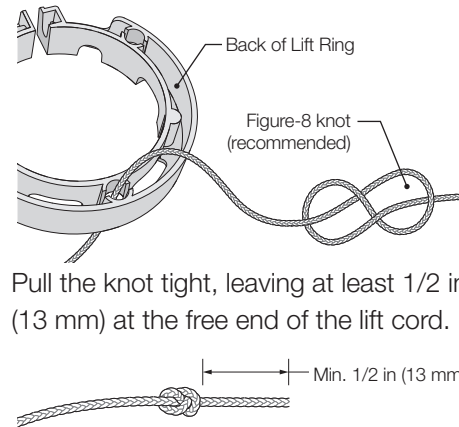

Pull the knot tight, leaving at least 1/2 in (13 mm) at the free end of the lift cord.

Pull the excess Lift Cord back through the hole in the Lift Ring. Slip the cord into the V-notch on one side of the hole as shown:

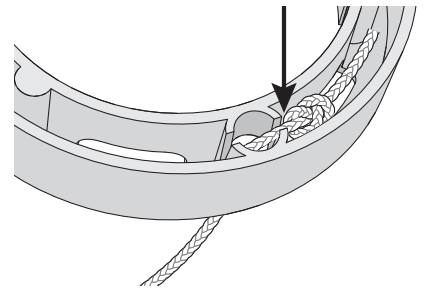

Tuck the knot into the back of the ring against the notch to secure the cord.

Lift Ring Installation

Install Lift Rings on the tube to coincide with the number and spacing of lift cords on the fabric panel.

Lift Rings are made of a flexible material that allows them to be twisted open:

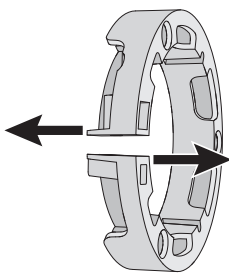

Twist the ends apart in opposite directions. Slip one end over the tube, and the other end under the tube, then allow the ring to un-twist and wrap around the tube.

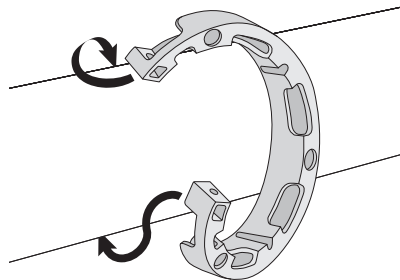

Slide the Lift Ring along the tube, aligning it with a lift cord position.

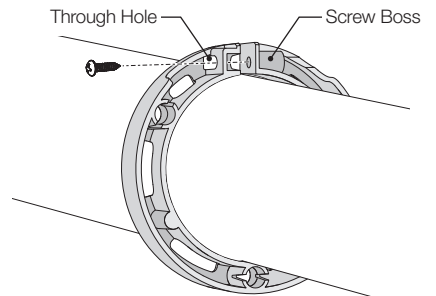

Install a Lift Ring screw as shown to secure the Lift Ring to the tube.

Job Name:	Model Numbers:
Job Number:	

Kit Configuration and Assembly *(continued)*

Spring-Balancing the Shade: Determining the Number of Spring Modules

The kit assembly ships from the factory with one (1) spring module pre-installed along with individual spring modules to be added (if configured).

Use the tables below to determine the TOTAL number of modules required to properly balance the shade based on shade width, height, and fabric used. Add spring modules accordingly prior to testing the shade. Spring modules may need to be added or removed based on the actual weights of the fabric panel built.

Step 1: Determine the total shade panel weight. Total shade panel weight is the sum of weights of the fabric and lining used for the shade.

Step 2: Determine the total springs needed based on the width/height of the shade. Round down to the nearest foot.

Step 3: Add spring modules (as needed) and run spring balance validation test. Refer to the SPRING-BALANCING THE SHADE section.

TOTAL NUMBER OF SPRING MODULES REQUIRED (pre-installed + add-in) SHEER FABRIC (15 oz/yd² total panel weight)

		FABRIC PANEL WIDTH (inches)							
		24	36	48	60	72	84	96	108
FABRIC PANEL HEIGHT (inches)	24	1	1	1	1	1	1	1	1
	36	1	1	1	1	1	1	1	1
	48	1	1	1	1	1	1	2	2
	60	1	1	1	1	1	2	3	3
	72	1	1	1	1	2	3	3	4
	84	1	1	1	2	2	4	4	5
	96	1	1	1	2	3	3	4	5
	108	1	1	2	3	3	4	5	6
	120	1	1	2	3	4	5	6	6

Continued on the next page...

Job Name:	Model Numbers:
Job Number:	

Kit Configuration and Assembly *(continued)*

Spring-Balancing the Shade: Determining the Number of Spring Modules

**TOTAL NUMBER OF SPRING MODULES REQUIRED (pre-installed + add-in)
FABRIC WITH PRIVACY LINING (25 oz/yd² total panel weight)**

		FABRIC PANEL WIDTH (inches)							
		24	36	48	60	72	84	96	108
FABRIC PANEL HEIGHT (inches)	24	1	1	1	1	1	1	1	2
	36	1	1	1	1	2	3	3	3
	48	1	1	1	2	3	3	4	5
	60	1	1	2	3	4	4	5	6
	72	1	1	2	3	4	5	7	8
	84	1	2	3	4	5	6	8	
	96	1	2	3	5	6	7		
	108	1	3	4	5	7			
	120	1	3	4	6	7			

NOTE: Shade panels in the gray area exceed the lift capacity of the kit.

**TOTAL NUMBER OF SPRING MODULES REQUIRED (pre-installed + add-in)
FABRIC WITH BLACKOUT LINING (35 oz/yd² total panel weight)**

		FABRIC PANEL WIDTH (inches)							
		24	36	48	60	72	84	96	108
FABRIC PANEL HEIGHT (inches)	24	1	1	1	1	1	2	3	3
	36	1	1	1	2	3	4	5	5
	48	1	1	2	3	4	5	7	8
	60	1	2	3	4	6	7		
	72	1	3	4	5	7			
	84	2	3	5	6	8			
	96	2	4	5	7				
	108	2	4	6					
	120	3	5	7					

NOTE: Shade panels in the gray area exceed the lift capacity of the kit.

Job Name:	Model Numbers:
Job Number:	

Kit Configuration and Assembly *(continued)*

Spring-Balancing the Shade: Add a Spring Module

IMPORTANT: The system lock must be in place and engaged while adding or removing spring modules. Shade must be in lowest limit when configuring springs.

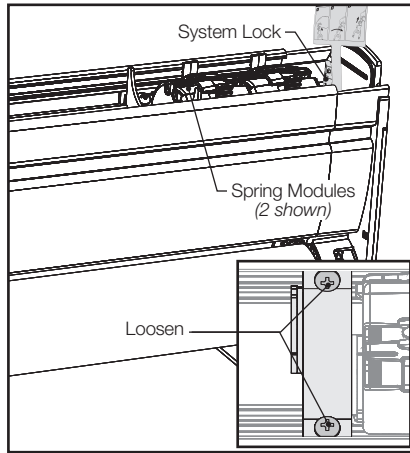

1. Loosen, but do not remove, the two (2) spring retention plate securing screws.

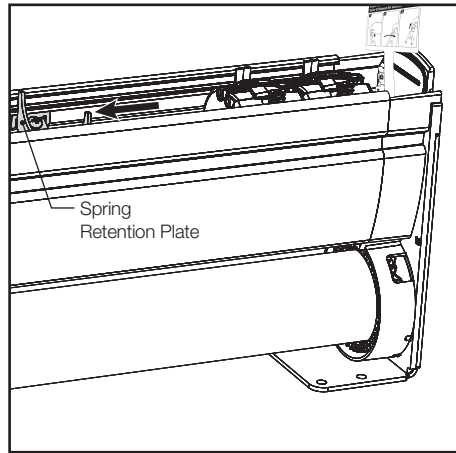

2. Slide the spring retention plate along the housing, away from the installed spring modules.

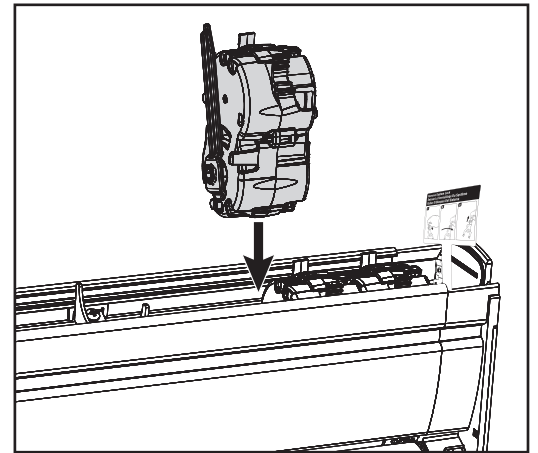

3. Remove the yellow label from the spring module and insert the module into the housing as shown, in line with the already-installed spring module(s). Press the spring module down into the housing until it locks into place with a 'CLICK'.

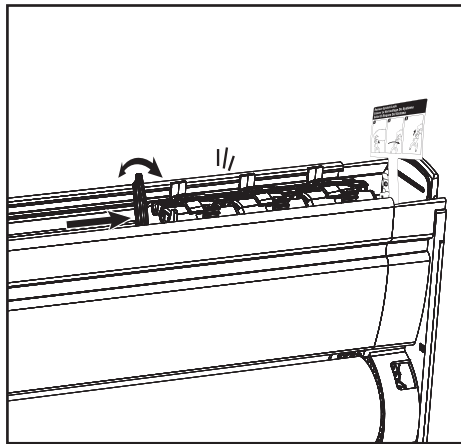

4. Slide the spring module along the housing toward the previously-installed module until it interlocks with the previously-installed module with a 'CLICK'. (The locking pin handle may be rotated slightly to help align the interlocking parts.)

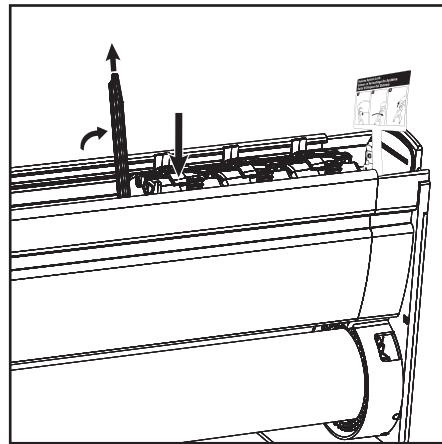

5. Holding the newly-installed spring module in place, rotate the locking pin handle and pull the locking pin up and out of the housing.

Repeat steps 3, 4, and 5 to install each additional spring module, as needed.

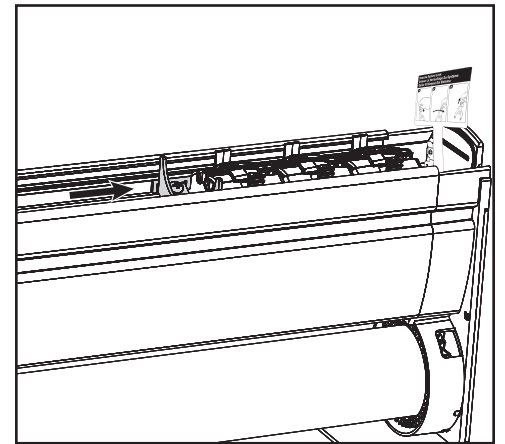

6. Slide the spring retention plate back along the housing until it touches the last spring module. Re-tighten the two (2) spring retention plate securing screws.

Job Name:

Model Numbers:

Job Number:

Kit Configuration and Assembly *(continued)*

Spring-Balancing the Shade: Remove a Spring Module

IMPORTANT: The system lock must be in place and engaged while adding or removing spring modules. Springs can only be added or removed when the shade is at its lower limit. Do not remove the spring locking pin until the spring module is fully installed. Removing the spring locking pin early will permanently damage the spring module.

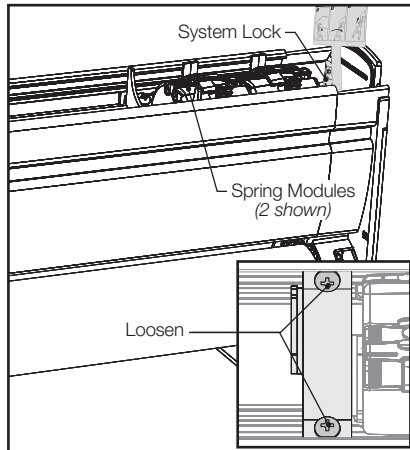

1. Loosen, but do not remove, the two (2) spring retention plate securing screws

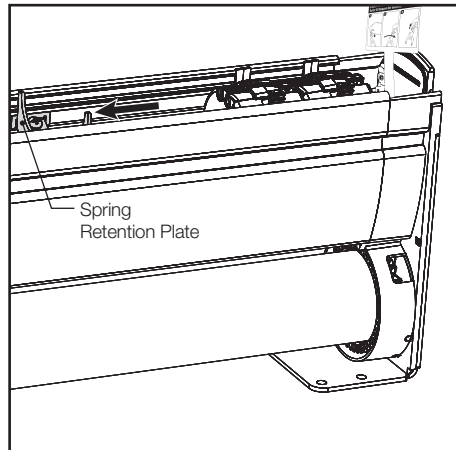

2. Slide the spring retention plate along the housing, away from the installed spring modules.

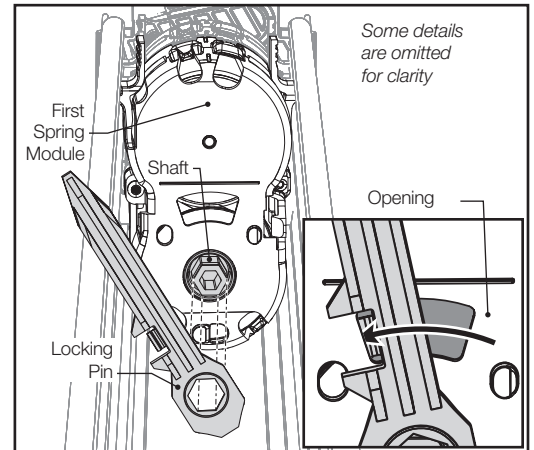

3. Install a locking pin on the first spring module. Align the hex-shaped hole in the locking pin with the hex-shaped spring module shaft as shown. Fit the locking pin on the shaft and rotate to lock it into the opening in the spring module housing.

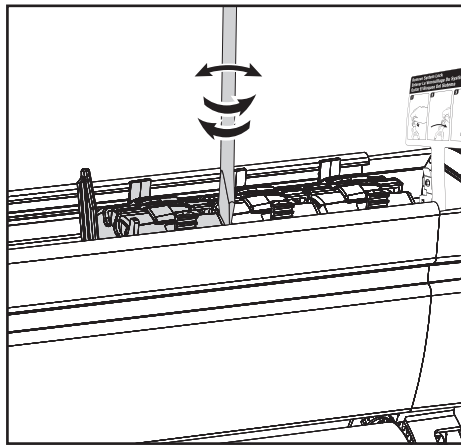

4. Slide a flat-blade screwdriver between the first and second spring modules as shown. Gently twist and rock the screwdriver to separate the interlocking parts of the modules.

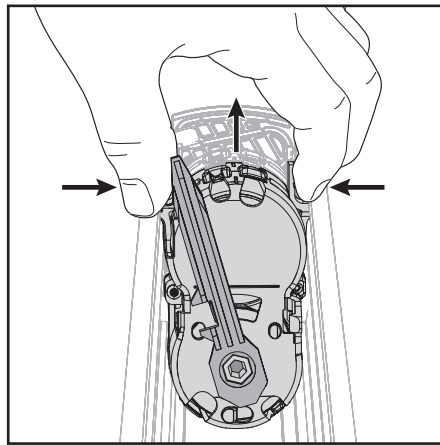

5. Squeeze the retaining tabs at the top of the spring module and lift the module up and out of the housing.

Repeat steps 3, 4, and 5 to remove any additional spring modules, as needed.

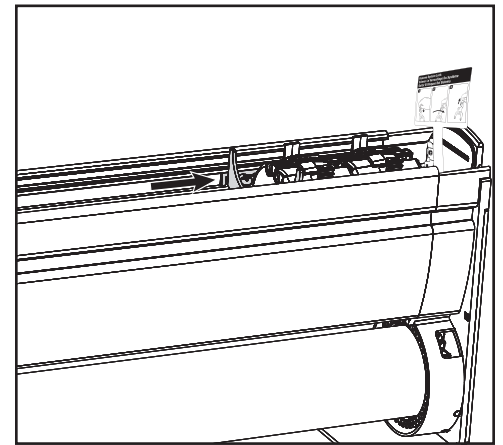

6. Slide the spring retention plate back along the housing until it touches the last spring module. Re-tighten the two (2) spring retention plate securing screws.

Job Name:

Model Numbers:

Job Number:

Kit Configuration and Assembly *(continued)*

Spring-Balancing the Shade: Prepare to Test Spring Balance

Install Batteries

At the open end of the battery holder, insert fresh 1.5 V D-cell alkaline batteries (quantity and orientation are specified on the battery holder). Do not mix battery brands, types, or ages. For Lutron recommended battery types, please see www.lutron.com/optimizing-battery-life

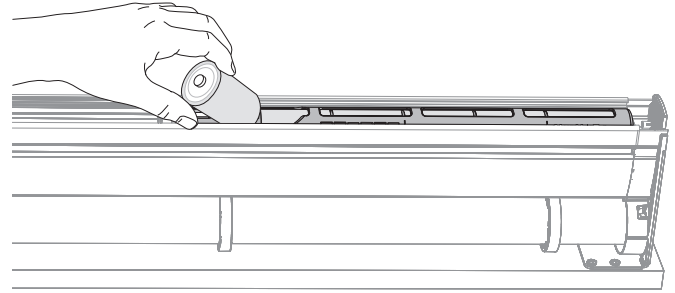

Install the Housing Cover

The housing cover has a hinge side and a latch side, and may be installed in either direction.

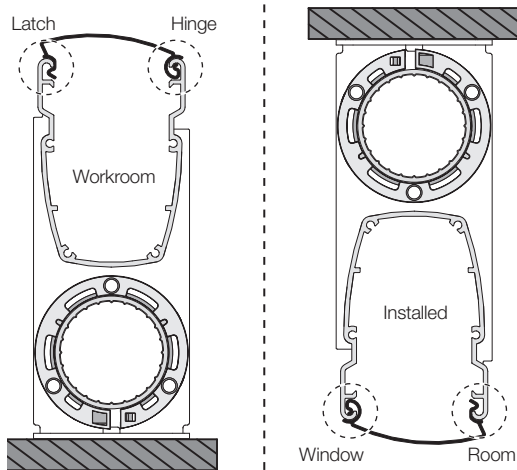

To allow future battery-change access, the hinge must be on the window side of the installed shade, with the latch on the room side.

After confirming which side of the kit housing will be on the window side when the shade is installed, align the hinge side of the housing cover end with the rolled edge of the housing on that side. Slide the cover all the way along the housing until the entire edge of the cover is engaged, and the cover fits between the housing endcaps.

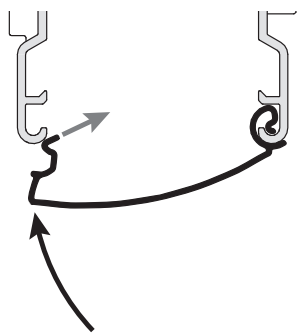
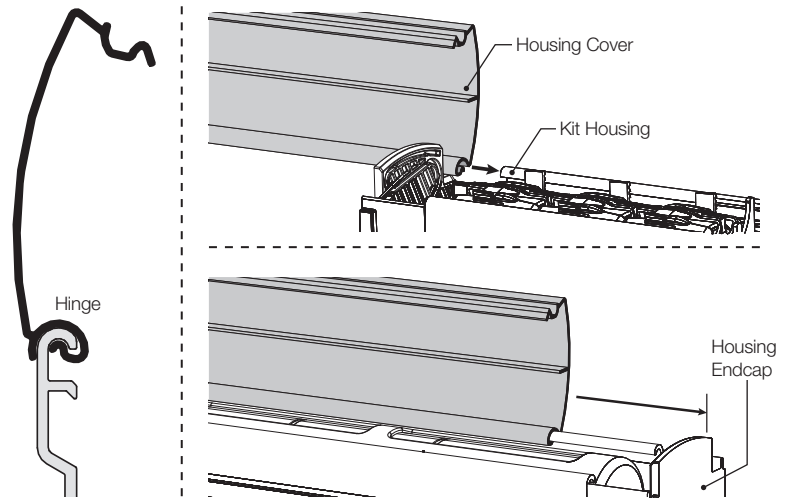

To close the housing cover, swing the latch side toward the housing and gently press it inside the edge of the housing to engage the latch.

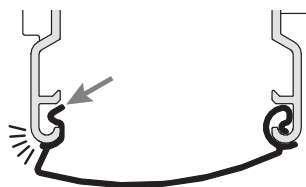

To open the housing cover, press in on the latch side and move it away from the housing.

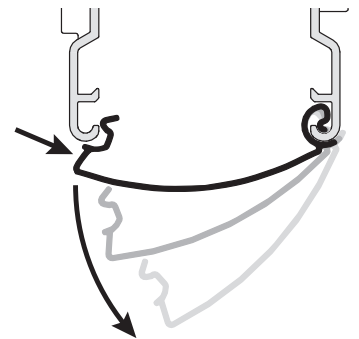

Job Name:	Model Numbers:
Job Number:	

Shade Setup and Testing

Spring-Balancing the Shade: Prepare to Test Spring Balance

Hang the Shade

Using appropriate mounting methods as applicable, hang the shade in a test location with ample space for the fabric to be fully raised and lowered without obstruction. Or, at the installation site, hang the shade in the window for which it is intended. In either case, verify the shade is securely mounted using brackets and/or fasteners capable of supporting the operating load. At this time, the fabric should be in the fully-lowered position, with all slack removed from the lift cords, and the kit housing cover open.

Remove the System Lock

At the end of the shade where the spring modules are installed, the system lock is located against the inside surface of the kit housing endcap. There is a flag attached to the locking clip to indicate its presence and location.

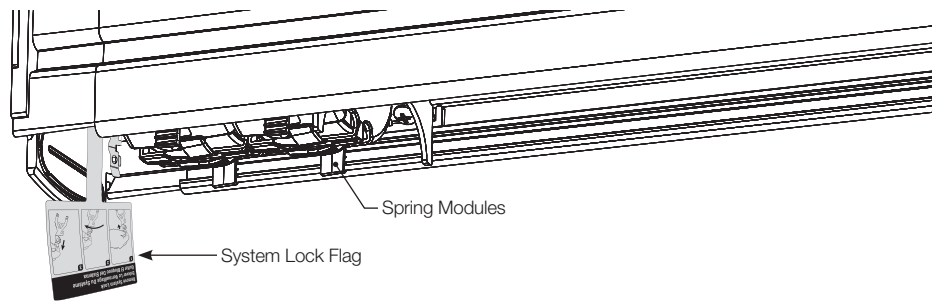

Refer to the diagrams on the system lock flag to remove the locking clip from the shade.

Additional system locks can be ordered in the event any have been lost or damaged.

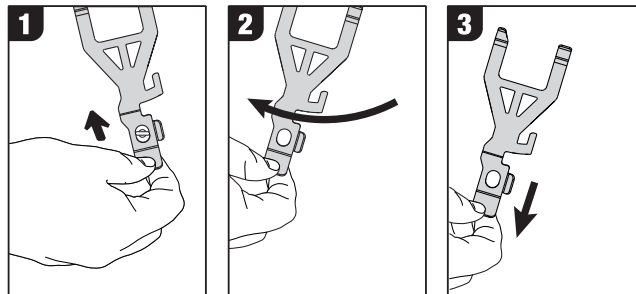

1 Pull the system locking clip away from the endcap and off its stop.

2 Rotate the clip away from the stop as shown.

3 Pull the clip away from the shade.

IMPORTANT: The system lock flag should be kept on the clip, and the lock should be reinstalled any time the shade will be adjusted, uninstalled, transported, or stored. Reinstalling the system lock is the reverse of removal.

Locate the Shade Button

At the end of the shade opposite the spring modules there is a shade button access opening in the part of the end bracket that surrounds the shade tube. You may use a small screwdriver or stylus to tap or press the shade button when instructed. The shade button is equipped with an LED that provides feedback during shade programming, testing, and operation.

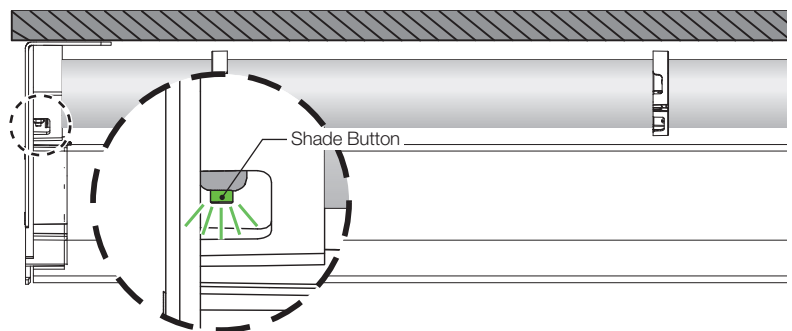





Job Name:	Model Numbers:
Job Number:	

Shade Setup and Testing *(continued)*

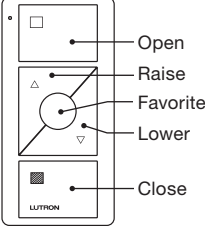
Spring-Balancing the Shade: Prepare to Test Spring Balance

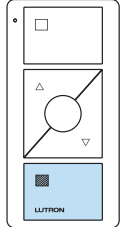



Assign a Pico Wireless Control

1. Tap the Shade button. The LED lights GREEN
2. Press and hold the Close button
3. The LED flashes GREEN rapidly. Assignment is complete

Set the Lower Limit

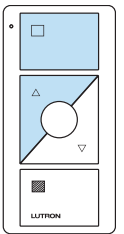

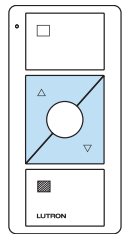
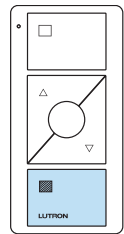

Product is shipped at the lower limit and should not need to be changed. The product may be damaged if taken below the factory-set lower limit.

1. Tap the Shade button. The LED lights GREEN
2. Press and hold the Open and Raise buttons simultaneously
3. The LED flashes GREEN rapidly, then stays lighted. Release all buttons
4. Use the Raise and Lower buttons to position the shade at the desired lower limit
5. Press and hold the Close button
6. The LED flashes GREEN rapidly. Assignment is complete

NOTE: If the shade stalls while lowering, or raises from lower limit without input from the control, a spring should be removed. Pull the shade to the lower limit and reinstall the system lock. Refer to the REMOVE A SPRING MODULE section on page 11.

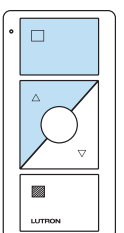
Set the Upper Limit

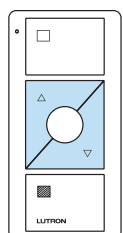
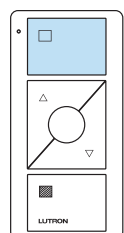
1. Tap the Shade button. The LED lights GREEN
2. Press and hold the Open and Raise buttons simultaneously
3. The LED flashes GREEN rapidly, then stays lighted. Release all buttons
4. Use the Raise and Lower buttons to position the shade at the desired upper limit
5. Press and hold the Open button
6. The LED flashes GREEN rapidly. Assignment is complete





NOTE: If the shade stalls while raising, or does not hold position where you would like the upper limit, an additional spring is required. Move the shade to its lower limit and refer to the ADD A SPRING MODULE section on page 10.

Shade Setup and Testing *(continued)*



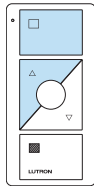

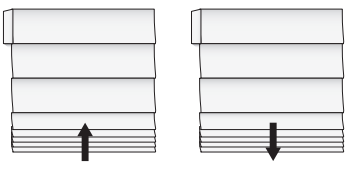







Spring-Balancing the Shade: Run the Spring Balance Validation Test

IMPORTANT: Upper and lower limits must be set according to the instructions on the previous page prior to running the spring balance validation test. The shade will travel up and down during the test; ensure there is ample clearance to allow free shade travel without obstruction or resistance other than the weight of the fabric.

Test the Spring Balance

1. Tap the Shade button. The LED lights GREEN. 
2. Press and hold the Open and Raise buttons simultaneously. 
3. Press and hold the shade button for 3 seconds, until the LED flashes GREEN rapidly. Release the button. 
4. The shade moves automatically to gauge spring balance. It will move to the lower limit (if not already at the lower limit), then raise and lower once. 
5. The shade button LED signals the test result. See below for blink code definitions. 

Test Result Blink Codes

<p>TEST PASSED The shade is balanced <i>The test is complete</i></p>	<p>The shade moves to its upper limit</p>	<p> GREEN 3 sec.  OFF 1 sec.</p>	<p>The pattern repeats for approximately 1 minute</p>	<p>To re-enter <i>Validation test</i> you may need to exit <i>Pico limit set mode</i> by holding the open and raise buttons simultaneously. The Pico will also timeout after ten minutes to its default state.</p>
<p>TEST FAILED The shade is under-sprung <i>Add one spring module and repeat the test</i></p>	<p>Shade remains at lower limit</p>	<p> GREEN 0.5 sec.  OFF 0.5 sec.  GREEN 0.5 sec.  OFF 0.5 sec.  GREEN 0.5 sec.  OFF 0.5 sec.  GREEN 3 sec.</p>	<p>The pattern repeats for approximately 1 minute</p>	
<p>TEST FAILED The shade is over-sprung <i>Remove one spring module and repeat the test</i></p>	<p>Shade remains in lower position</p>	<p> RED 0.5 sec.  OFF 0.5 sec.  RED 0.5 sec.  OFF 0.5 sec.  RED 0.5 sec.  OFF 0.5 sec.  RED 3 sec.</p>	<p>The pattern repeats for approximately 1 minute</p>	

NOTE: During operation or testing, the shade button LED may display blink codes not shown above, unrelated to the spring balance validation test. Issues with other shade features or functions may be indicated. A complete list of other possible blink codes please see <https://assets.lutron.com/a/documents/serena-triathlon-blink-codes.html>

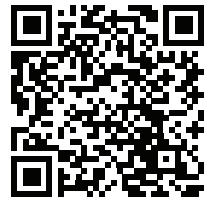

Shade Setup and Testing *(continued)*

Restoring Shades to Factory Default

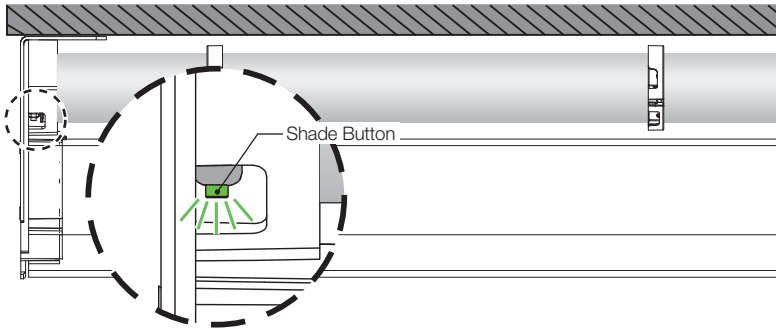

This step will remove any controls assigned to the shade. It will not affect the shade's upper and lower limits.

Step 1: Tap the shade button quickly 3 times, and hold the shade button after the third tap until the shade button LED blinks green rapidly.

Step 2: Immediately tap the shade button quickly three more times, until the shade button LED blinks green rapidly, then blinks red/green three times, and turns off.

The Lutron logo, Lutron, Caséta, HomeWorks, Pico, RA2 Select, RadioRA 3, Serena, and Triathlon are trademarks or registered trademarks of Lutron Electronics Co., Inc. in the US and/or other countries.

All other product names, logos, and brands are property of their respective owners.

LUTRON SPECIFICATION SUBMITTAL

Page

Job Name:	Model Numbers:
Job Number:	