

# CONTRACT SERIES ONE

## Medium Dual Fascia Roller Shade

12v Low Voltage / Solar / Li-Ion Motorized Control



The Rollease Acmeda Contract Medium Dual Fascia system is the most comprehensive shading system available. With a myriad of powering options our commercial duty Contract Series One system supports low voltage powering through custom power panels, plug in transformers, solar powered PV arrays or our game changing rechargeable Li-ion internal batter system. The 5" system offers a robust, large shade system with a smooth operation that can handle shades up to 16' wide and up to 280 sq.ft. before linking. Significantly heavier and impressive shading systems require precision engineered, heavy duty hardware, that can support multiples of its own weight. Heavy duty steel brackets and locking idler and motor side features provide maximum security for larger applications. The perfect solution for internal commercial applications; the Contract Series One Medium Dual Fascia System creates new opportunities to achieve larger, more impactful shades.

### Features:

- Max width of 16' (based on 18' drop). Capacity to cover areas up to 280 sq.ft. before linking.
- Linking options for single and dual shade configurations.
- Automate motor Ultra-quiet operation with ARC bi-directional communication.
- Optional solar panel for environmentally forward, energy efficient constant system charging.
- Accepts standard or reverse roll configurations for versatile and efficient installation.
- Reverse Fascia / Top Back Cover for increased light control and to conceal hardware from street view.
- Powder coated steel box brackets made of 13 Gage Steel w thickness of .090" (2.28mm).



Match this solution with any of our sunscreen, blockout or high performance fabrics for a complete finished solution. See our document library for comprehensive information including HPD, LEED & NRC specifications.

### FINISH COLORS

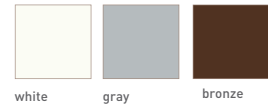

### MOTOR OPTIONS

**Automate Wall Switches**  
[Hand held or wall mounts]

**DC Power Panel**  
[Provides power for 18 DC ARC motors]

**Automate Solar Charger**  
[energy efficient]

**Automate ARC Repeater**  
[Extends the ARC signal]

**ARC Relay Module**  
[Smart System Interface]

**Automate Pulse Hub**  
[Smart Phone Control]

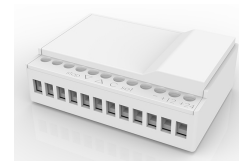

## FRONT & SIDE VIEW

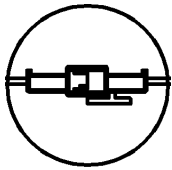
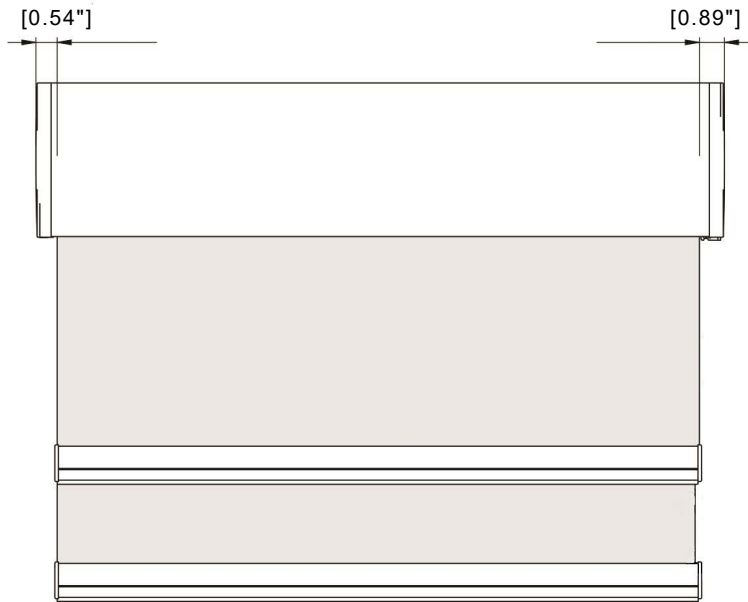
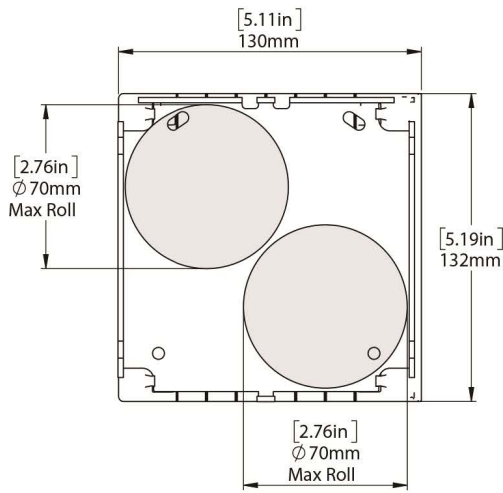

## SCHEMATIC

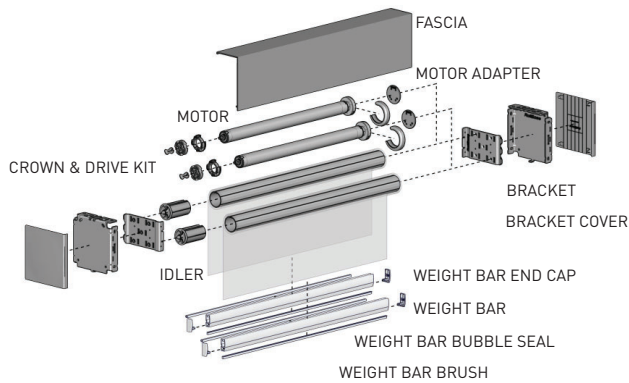

## BOTTOM RAIL OPTIONS

### D30 SILENT WEIGHT BAR

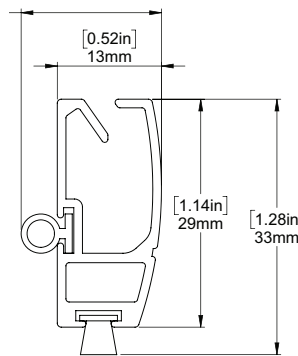

### INTERNAL HEM BAR

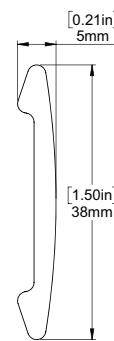

### F4115 HEM BAR

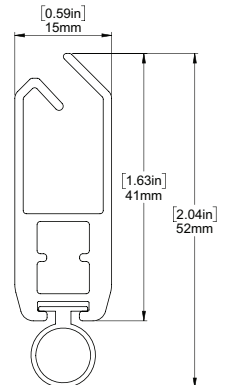

## SYSTEM UPGRADES

### Pocket

[for hidden recess mounts]



### Edge Side Channels

[for improved light blackout]



### Internal Wire Guide

[supporting complex shading systems]



### Fabric Switch System

[fast easy changing of fabric on a roller shade]

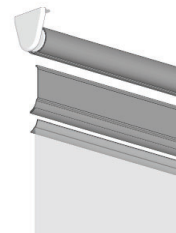

For more information about our Upgrade solutions, see our UPGRADE SPECIFICATION sheets.

**PORTER PRESTON**

Quality Wholesale Window Coverings  
Contract • Hospitality • Healthcare • Residential

ph 203-753-1113 customer.service@porterpreston.com www.porterpreston.com